

# Power transfer stabilization of the three-phase contactless energy transfer desktop by means of coil commutation

**Citation for published version (APA):**

Sonntag, C. L. W., Lomonova, E. A., & Duarte, J. L. (2008). Power transfer stabilization of the three-phase contactless energy transfer desktop by means of coil commutation. In L. Encica, B. L. J. Gysen, J. W. Jansen, & D. C. J. Krop (Eds.), *4th IEEE Benelux Young Researchers Symposium in Electrical Power Engineering, Eindhoven, The Netherlands, 7-8 February, 2008* Technische Universiteit Eindhoven.

**Document status and date:**

Published: 01/01/2008

**Document Version:**

Publisher's PDF, also known as Version of Record (includes final page, issue and volume numbers)

**Please check the document version of this publication:**

- A submitted manuscript is the version of the article upon submission and before peer-review. There can be important differences between the submitted version and the official published version of record. People interested in the research are advised to contact the author for the final version of the publication, or visit the DOI to the publisher's website.
- The final author version and the galley proof are versions of the publication after peer review.
- The final published version features the final layout of the paper including the volume, issue and page numbers.

[Link to publication](#)

**General rights**

Copyright and moral rights for the publications made accessible in the public portal are retained by the authors and/or other copyright owners and it is a condition of accessing publications that users recognise and abide by the legal requirements associated with these rights.

- Users may download and print one copy of any publication from the public portal for the purpose of private study or research.
- You may not further distribute the material or use it for any profit-making activity or commercial gain
- You may freely distribute the URL identifying the publication in the public portal.

If the publication is distributed under the terms of Article 25fa of the Dutch Copyright Act, indicated by the "Taverne" license above, please follow below link for the End User Agreement:

[www.tue.nl/taverne](http://www.tue.nl/taverne)

**Take down policy**

If you believe that this document breaches copyright please contact us at:

[openaccess@tue.nl](mailto:openaccess@tue.nl)

providing details and we will investigate your claim.

# Power Transfer Stabilization of the Three-Phase Contactless Energy Transfer Desktop by means of Coil Commutation

C. L. W. Sonntag, E. A. Lomonova, and J. L. Duarte.

**Abstract**— In this paper, a method for removing the “dead spots” and stabilizing the position-sensitive power transfer efficiency in a three-phase contactless energy transfer desktop is presented. “Dead spots” result from the non-uniform distribution of the primary coils’ magnetic field intensities and the out-of-phase currents they are excited with. When the secondary coil is inside a “dead spot” there is no induced voltage, secondary current, or power transfer. The primary controller can not distinguish between a “dead spot” and a fully charged “receiving device” drawing no current. In this work it is shown, that a temporary unbalancing of the currents inside an activated primary coil cluster will result in an induced secondary voltage. The resultant secondary current flow will produce changes in the primary coils’ voltage and phase which can be detected by the primary controller. Following this method, the primary controller can detect “dead spots” and remove them by disabling and energizing different primary coils.

**Index Terms**— Contactless energy transfer, “Dead spots”, Hexagon spiral windings.

## I. INTRODUCTION

CONTACTLESS ENERGY TRANSFER (CET) is the process in which electrical energy is transferred among two or more electrical devices through inductive coupling as opposed to energy transfer through conventional “plug-and-socket” connectors [1]. CET desktop applications and other similar CET charging platforms are realizations of this concept where a table or a platform embedded with “power transmitting” coils, have the ability to power or recharge different consumer electronic devices, such as cellular phones, portable music-and multimedia players and laptops, fitted with “power receiving” coils, by simply placing the devices on top of the desk or platform (Fig. 1). In [2], a CET desktop application is presented which utilizes a matrix of hexagon spiral windings embedded underneath the surface of a table. When a “receiving device” is placed on the table, a cluster of three primary coils, located closest to the device is activated to transfer power to the device. Furthermore, in an attempt to

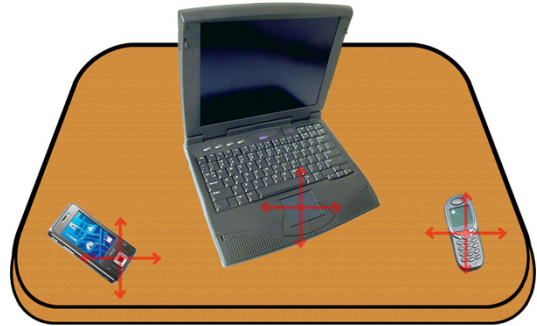

Fig. 1. CET receiver objects randomly placed on a CET enabled desktop of charging.

minimize stray magnetic fields, the coils within the activated cluster are excited with out-of-phase current waveforms. It is shown in [1] that these out-of-phase currents produce out-of-phase magnetic fields which reduce stray magnetic fields due to deconstructive interference. Unfortunately, inherent to the design of the CET desktop are “dead spots” or positions on the table where no transfer of energy occurs. This is due to the non-uniform distribution of the primary coil’s magnetic field intensity and the out-of-phase currents they are excited with.

In [2], it was postulated and shown that a receiver configuration with multiple small secondary windings (referring to secondary windings smaller than the primary windings) was able to stabilize the power transfer and remove the “dead spots”. The problem with this assumption is that it does not take into account certain practical implication, such as the losses due to the multiple rectifying diodes needed to combine the power from the multiple secondary windings. Low electromagnetic coupling, self- and mutual inductances may also lead to lower efficiencies and limited secondary induced voltages.

The problem addressed in this paper, is that of detecting and removing “dead spots” related to large secondary windings (being larger than the primary windings). When a secondary winding is indeed inside a “dead spot” the individual out-of-phase secondary induced voltages cancel each other out which results in a zero net voltage and subsequently no current flow. In such a situation the primary controller can not distinguish between a “dead spot” and a fully charged “receiving device” not drawing any current. To solve this, the controller reduces the current in one of the primary windings. This results in an

unbalancing of the individual secondary induced voltages with a non-zero net voltage appearing over the terminals of the secondary winding. As the “receiving device” starts drawing power, the secondary current will in turn produce a change in the primary winding voltages and phases, which can be detected by the controller. The controller can thus detect and remove the “dead spots” by disabling one of the primary windings and energizing an opposing winding of the same phase. It is shown through simulations that all “dead spots” can be removed by this method.

## II. THE CONTACTLESS ENERGY TRANSFER DESKTOP

In the CET desktop application a wooden or plastic table is embedded with a matrix of hexagon spiral windings just a few millimeters (typically 1 – 2 mm) below its surface (Fig. 2). Incorporating the magnetic field shaping technology presented in [1], the primary windings are arranged so that adjacent windings are excited with out-of-phase sinusoidal current waveforms. As shown in Fig. 2, the windings labeled “A”, “B”, and “C” are excited by currents with  $0^\circ$ ,  $120^\circ$ , and  $240^\circ$  current phase angles, respectively. When a CET enabled electronic device is placed on the table, a cluster of three primary out-of-phase excited windings, located closest to the receiving device, are activated to transfer the power.

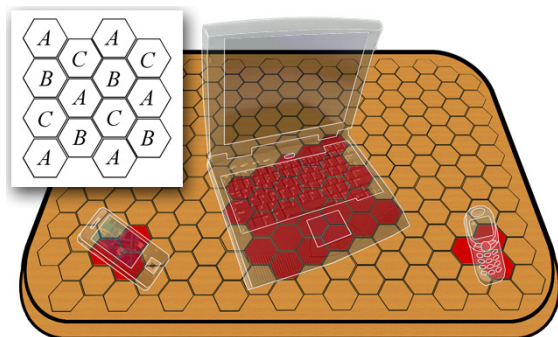

Fig. 2. The CET desktop, showing the individual primary windings with an insert of the primary winding matrix showing the individual winding current phases.

The CET desktop application is specifically designed to operate as a replacement for the power supplies and adaptors which convert the 240 V, 50 Hz mains voltage to low voltage DC signals, for charging and operating small electronic devices such as cellular phones, portable multimedia players and laptops. For this reason a few specifications for the CET system are presented:

- A single secondary winding should fit into a standard cellular phone or is casing (approx. 20 mm radius).
- The minimum secondary load voltage should be no less than 10 V (rms).
- The airgap between the primary and secondary windings may not exceed 5 mm.
- The CET system should be able to transfer at least 8 W of power to the load device.

- The primary and secondary winding losses should not exceed 2 W.

The primary and secondary hexagon spiral winding radii, track widths, currents amplitudes and switching frequency are specifically chosen to comply with these specifications. The physical dimensions and electrical properties of the hexagon spiral windings are shown in Table I, and the circuit parameters in Table II.

TABLE I  
PHYSICAL DIMENSIONS AND ELECTRICAL PROPERTIES OF THE HEXAGON SPIRAL WINDINGS

Parameter	Primary Winding Value	Secondary Winding Value
Radius	12 mm	20 mm
Turns	13	23
Thickness	105 $\mu\text{m}$	105 $\mu\text{m}$
Track width	0.5 mm	0.5 mm
Track spacing	0.25 mm	0.25 mm
Inductance	5.72 $\mu\text{H}$	7.44 $\mu\text{H}$
Resistance (DC)	0.17 $\Omega$	0.46 $\Omega$
Resistance (AC)	2.30 $\Omega$	2.16 $\Omega$

TABLE II  
CET DESKTOP CIRCUIT PARAMETERS

Parameter	Value
Primary current amplitude	960 mA (rms)
Signal frequency	2.777 MHz
Primary resonance capacitor	574 pF
Secondary resonance capacitor	441 pF
Airgap range	1 - 5 mm

Each hexagon spiral winding is powered by a single-phase half-bridge inverter. The hexagon winding is modelled as a resistor and inductor in series, and together with its series resonant capacitor, forms a band-pass filter for the current, allowing only the fundamental switching frequency current to flow through the winding. This together with a digital controller, a high speed MOSFET driver and a DC-to-DC converter maintains a constant AC current through the winding under variable loads. Figure 3, shows a schematic diagram of this circuit.

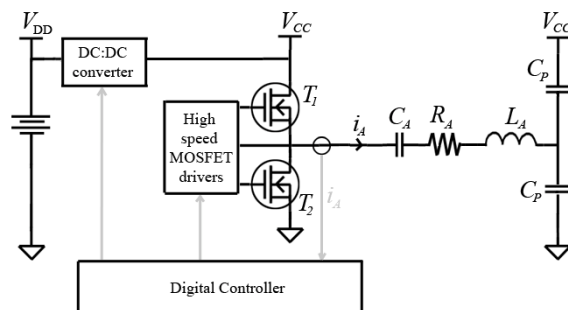

Fig. 3. A schematic diagram of switching circuit which powers a primary winding.

Here  $T_1$  and  $T_2$  are the half-bridge inverter MOSFETs,  $i_A$  is the current through the winding,  $C_A$  is the resonant capacitor, and  $R_A$  and  $L_A$  are the winding-resistance and self inductance, respectively. The DC blocking capacitors are labeled  $C_P$ . For the purpose of this paper, the operations of neither the high speed MOSFET drivers, the DC-DC converter, nor the digital controller will be discussed.

### III. "DEAD SPOTS" AND COMMUTATION

The origin of the "dead spots" and the proposed solution can best be explained by viewing Fig. 4 and Fig. 5. In Fig. 4, a two-dimensional (top view) of a hexagon spiral winding matrix with the primary cluster windings  $S_A$ ,  $S_B$ ,  $S_C$ , and  $S'_C$ , and secondary winding  $S_D$ , is shown.

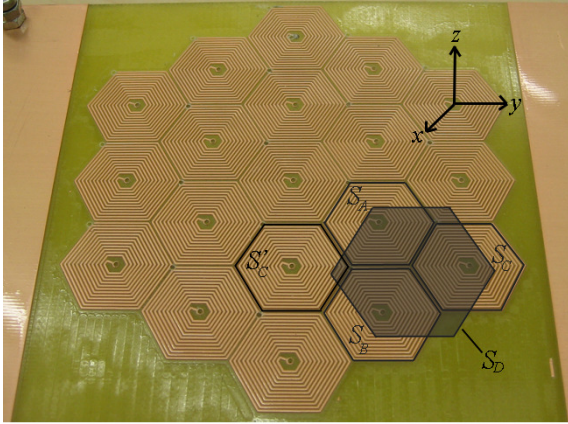

Fig. 4. A matrix of hexagon spiral windings showing the primary cluster  $S_A$ ,  $S_B$ , and  $S_C$ , as well as secondary winding  $S_D$ .

Figure 5, shows a simplified schematic diagram of the CET circuit where a cluster of hexagon spiral windings are transferring power to the load device. The half-bridge inverters and control system which maintains the constant primary currents are replaced by current sources.

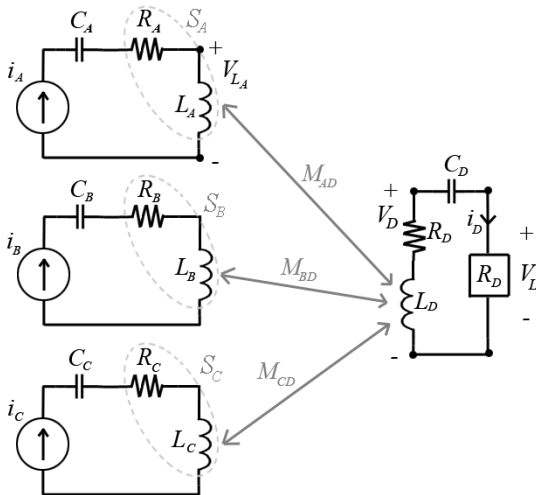

Fig. 5. A simplified schematic diagram of the CET power transferring process.

Here,  $i_A$ ,  $i_B$ , and  $i_C$  are the three primary windings' current sources;  $R_A$  and  $L_A$ ,  $R_B$  and  $L_B$ , and  $R_C$  and  $L_C$ , are the internal resistances and self inductances of the three primary windings,  $S_A$ ,  $S_B$  and  $S_C$ , respectively. On the secondary side,  $R_D$  and  $L_D$  are the internal and self inductance of the secondary winding  $S_D$ ,  $V_D$  is the voltage over the secondary winding;  $C_D$  is the secondary resonance capacitor;  $R_D$  is the secondary resistive load, with  $V_L$  the voltage over  $R_D$ , and  $i_D$  is the secondary current;  $M_{AD}$ ,  $M_{BD}$  and  $M_{CD}$  are the mutual inductances between the three primary coils  $S_A$ ,  $S_B$  and  $S_C$  and the secondary coil  $S_D$ , respectively

The currents in the three primary windings inside an activated cluster can be written as:

$$i_A(t) = I_0 e^{j\omega t + j0}, \quad (1)$$

$$i_B(t) = I_0 e^{j\omega t + j\pi/3}, \quad (2)$$

$$i_C(t) = I_0 e^{j\omega t + j\pi/3}, \quad (3)$$

where  $I_0$  is the current amplitude and  $\omega$  is the radial frequency of the signal. The induced voltage at the secondary winding is:

$$V_D = M_{AD} \frac{d}{dt} i_A + M_{BD} \frac{d}{dt} i_B + M_{CD} \frac{d}{dt} i_C. \quad (4)$$

Substituting (1), (2) and (3) in (4) yields:

$$V_D = j\omega I_0 e^{j\omega t} (M_{AD} + e^{j\pi/3} M_{BD} + e^{j\pi/3} M_{CD}). \quad (5)$$

In (5), the causes of the "dead spots" become clear. When the secondary winding is placed so that the individual primary-to-secondary mutual inductances are approximately equal, the induced voltage  $V_D$ , will become zero, resulting in no power transfer. The currents in the primary windings are controlled by the digital controller, which monitors the voltages over the primary windings and energizes the correct windings (coil commutation). In a situation like this, the controller has no way of knowing whether the "receiving device" is simply fully charged and not drawing any power or whether it has encountered a "dead spot". To solve this, the controller temporarily reduces the current in one of the primary windings to zero. If the "receiving device" is simply not drawing any current this will result in a temporary drop in secondary induced voltage and should have a minimal effect on the load. If however, the system has indeed come across a "dead spot", the momentary unbalancing of the individual induced voltages will produce a non-zero net secondary voltage. As power is drawn by the load, the flow of secondary current will cause a change in voltage and phase over the primary windings, which can be detected by the controller.

Since the original primary coil cluster will no longer suffice in powering the "receiving device", a rearrangement of the primary coil cluster is done by disabling one of the primary windings and exciting one of the adjacent windings of the

same phase (coil commutation). Figure 4 shows a situation where the system has encountered a “dead spot”. In this case:  $M_{AD} \approx M_{BD} \approx M_{CD}$ , and thus  $V_D$  is approximately zero.

To detect the “dead spot”, the current in winding  $S_c$  is reduced to zero, in which case the secondary induced voltage becomes:

$$V_D \approx j\omega I_0 M_{AD} e^{j\omega t - j\pi/3}. \quad (6)$$

The “dead spot” is removed by simply disabling winding  $S_c$  and energizing winding  $S'_c$ . Since  $S'_c$  couples very weakly with  $S_D$  it does not contribute to the secondary induced voltage or transfer of power to the “receiving device”, it does however contribute to the reduction of the stray magnetic fields due to the destructive interference of the individual magnetic fields.

#### IV. SIMULATIONS

To demonstrate the working of the coil commutation and how it is used to remove the “dead spots”, various simulations are conducted. In the first set of simulations, the secondary load voltage is estimated for an infinitely large resistive load ( $R_D \rightarrow \infty$ ) without applying the coil commutation method presented in this paper. With the primary cluster placed at the axis center of the  $xy$ -plane, the secondary winding is moved around in the  $x'y'$ -plane at a height of 1 mm above the primary windings from -24 mm to 24 mm in the  $x'$ -direction, and from -21 mm to 21 mm in the  $y'$ -direction, with 1 mm increments in both directions. At every position the load voltage is calculated. Figure 6 shows the result of the simulation.

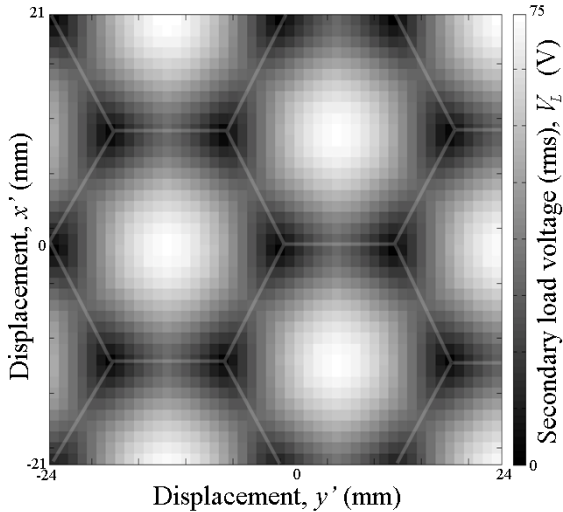

Fig. 6. Two-dimensional (top view) secondary load voltage plot when no “dead spot” cancellation is applied (no load).

The simulation is then repeated, estimating the secondary load voltage with the secondary winding at a height of 5 mm. Figure 7 shows the result of the simulation.

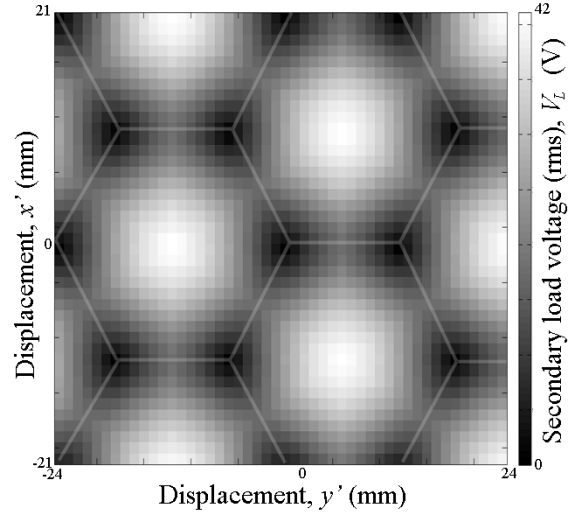

Fig. 7. Two-dimensional (top view) secondary load voltage plot when no “dead spot” cancellation is applied (no load).

From Fig. 6 and Fig. 7, multiple distinctive high voltage locations are seen. As expected they correspond to the centers of the primary windings. Due to the three-phase cancellation effect multiple “dead spots” are shown at the vertices of the hexagon spiral windings. Areas around the vertices of the windings, called the “dead zones”, can be defined. These are areas where the secondary load voltage is smaller than the minimum required voltage, as stated by the specifications. These areas are roughly circular in shape, with the radii of the “dead zones” ranging from 2.5 mm for the first simulation to 4 mm for the second.

In the second set of simulations, the coil commutation method, presented in the paper, is applied. The secondary winding is moved around in the  $x'y'$ -plane at a height of 1 mm above the primary windings from -12 mm to 12 mm in the  $x'$ -direction, and from -10.5 mm to 10.5 mm in the  $y'$ -direction. At each position the load resistance is changed as to dissipate 8 watt of power. The secondary load voltage is calculated and the results are shown in Fig. 8.

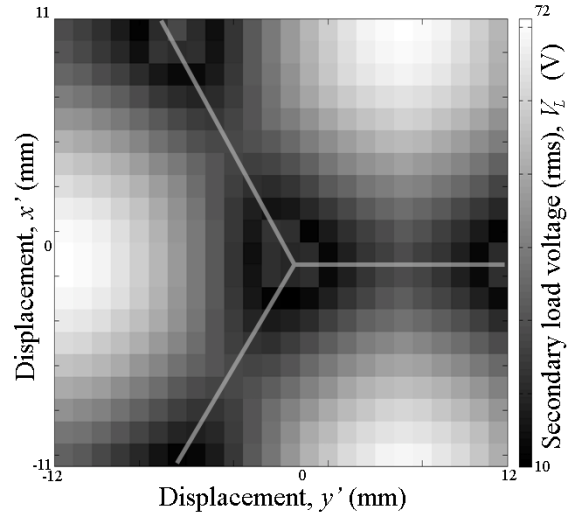

Fig. 8. Two-dimensional (top view) secondary load voltage plot when the “dead spot” cancellation is applied for an 8 W load.

The simulation is then repeated, estimating the secondary load voltage at a height of 5 mm. Figure 9 shows the result of the simulation.

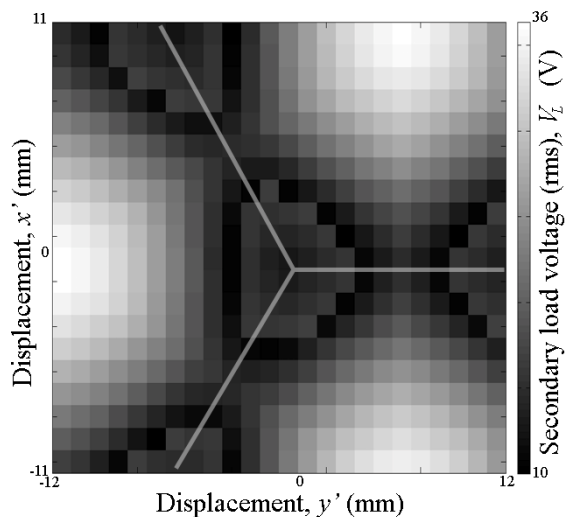

Fig. 9. Two-dimensional (top view) secondary load voltage plot when the “dead spot” cancellation is applied for a 8 W load.

From Fig. 8 and Fig. 9, it is shown that all the “dead spots” are removed and that the minimum load voltage is 10 V (rms) for the 1 mm and 5 mm simulations, respectively.

## V. CONCLUSIONS

In this paper, a method for removing the “dead spots” and stabilizing the position-sensitive power transfer efficiency in a three-phase contactless energy transfer desktop is presented.

When a secondary winding is inside a “dead spot” no power can be transferred to it. The primary controller can not distinguish between a “dead spot” and a fully charged “receiving device”. By following the method described in this paper, the controller can detect the “dead spots” and remove them by disabling one of the primary windings and energizing an opposing winding of the same phase.

In the first set of simulations, the secondary load voltage is estimated for an infinitely large resistive load without applying the coil commutation method presented in this paper. Here multiple “dead spots”, and areas called “dead zones”, are shown at the vertices of the hexagon spiral windings.

In the second set of simulations, the coil commutation method, presented in the paper, is applied, and power is transferred to a 8 W resistive load. From the simulation results it is shown that all the “dead spots” are removed and that the minimum secondary load voltage as required by the system specifications is maintained.

## REFERENCES

- [1] C. L. W. Sonntag, E. A. Lomonova, J. L. Duarte, A. J. A. Vandenput, and A. J. M. Pemen, “Contactless Energy Transfer for Office and Domestic Applications,” Proc. International Conference on Electrical Machines, ICEM 2006, Greece, pp. 1-6, September 2006.
- [2] C. L. W. Sonntag, E. A. Lomonova, J. L. Duarte and A. J. A. Vandenput, “Specialized Receiver for Three-Phase Contactless Energy Transfer Desktop Applications,” The 12<sup>th</sup> European Conference on Power Electronics and Applications, pp. 1-11, September 2007.