

Photoionization/streamer propagation

Citation for published version (APA):

Nijdam, S., Veldhuizen, van, E. M., & Ebert, U. (2012). Photoionization/streamer propagation. In *Presentation at XIIIth International symposium on High Pressure Low Temperature Plasma Chemistry HAKONE XIII September 9 – 14, 2012, Kazimierz Dolny, Poland*

Document status and date:

Published: 01/01/2012

Document Version:

Accepted manuscript including changes made at the peer-review stage

Please check the document version of this publication:

- A submitted manuscript is the version of the article upon submission and before peer-review. There can be important differences between the submitted version and the official published version of record. People interested in the research are advised to contact the author for the final version of the publication, or visit the DOI to the publisher's website.
- The final author version and the galley proof are versions of the publication after peer review.
- The final published version features the final layout of the paper including the volume, issue and page numbers.

[Link to publication](#)

General rights

Copyright and moral rights for the publications made accessible in the public portal are retained by the authors and/or other copyright owners and it is a condition of accessing publications that users recognise and abide by the legal requirements associated with these rights.

- Users may download and print one copy of any publication from the public portal for the purpose of private study or research.
- You may not further distribute the material or use it for any profit-making activity or commercial gain
- You may freely distribute the URL identifying the publication in the public portal.

If the publication is distributed under the terms of Article 25fa of the Dutch Copyright Act, indicated by the "Taverne" license above, please follow below link for the End User Agreement:

www.tue.nl/taverne

Take down policy

If you believe that this document breaches copyright please contact us at:

openaccess@tue.nl

providing details and we will investigate your claim.

PHOTO AND BACKGROUND IONIZATION/ STREAMER PROPAGATION

S. Nijdam¹, E.M. van Veldhuizen¹, U. Ebert^{1,2}

¹ Eindhoven University of Technology, Dept. Applied Physics, Eindhoven, NL

² Centrum Wiskunde & Informatica, Amsterdam, The Netherlands

E-mail: s.nijdam@tue.nl

Positive streamers in air and other oxygen-nitrogen mixtures are generally believed to propagate against the electron drift direction due to photo-ionization. Photo-ionization is the non-local ionization of O₂-molecules by UV radiation from excited N₂-molecules. This facilitates the streamer propagation by creating free electrons ahead of it. The relative importance of photo-ionization depends on the O₂/N₂ ratio. Another possible source of free electrons in front of the positive streamer is background ionization. This can be ionization left by previous discharges or by other processes such as cosmic rays or (natural) radio-activity. We study the effects of both photo- and background-ionization on propagation and morphology of positive streamers by changing gas composition and repetition frequency. One particular gas composition is pure nitrogen with a small amount of radio-active ⁸⁵Kr added to increase background ionization.

1. Introduction

Positive streamers need a continued source of free electrons in front of them in order to propagate. Because of the electronegativity of molecular oxygen, free electrons in air quickly attach to oxygen if the electric field is below about 30 kV/cm. If this is the case, a high field is needed to detach the electrons so that they can be accelerated. According to Pancheshnyi [1] and Wormeester et al. [2], a good value for the instant detachment field under standard conditions in air is 38 kV/cm.

The detached free electrons can form avalanches that feed the front of the streamer head and enable it to propagate. The density of the electrons influences the morphology of the streamers as was demonstrated in [3].

In most streamer models the medium is air and the major source of electrons in front of the streamer head is taken as photo-ionization. In air, photo-ionization occurs when a UV photon in the 98 to 102.5 nm range, emitted by an excited nitrogen molecule, ionizes an oxygen molecule, thereby producing a free electron:

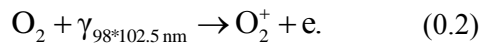
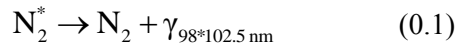

1.2 Photo-ionization

As the emitted photon can ionize an oxygen molecule some distance away from its origin, this is a non-local effect and therefore excited nitrogen molecules in the streamer head can create free electrons in front of the streamer head (as well as at other places around the streamer head). The average distance that a UV photon can travel depends on the density of the absorbing species, oxygen in this case. In atmospheric pressure air under standard conditions, this distance will be about 1.3 mm [4].

A straightforward method to test the effects of photo-ionization is by varying the oxygen concentration in nitrogen-oxygen mixtures and studying the effect of this on streamer properties. We performed such experiments with oxygen concentrations ranging from less than 0.1 ppm (parts per million) to 20% (artificial air).

1.2 Background ionization

Besides photo-ionization, there is another source that can provide free electrons in front of a positive streamer head: background ionization. Background ionization is ionization that is already present in the gas before the streamer starts, or at least it is not produced by the streamer. It can have different sources. In ambient air, radioactive compounds (e.g. radon) from building materials and cosmic rays are the most important sources of background ionization. They lead to a natural background ionization level of 10⁹ -10¹⁰ m⁻³ at ground level (Pancheshnyi [1] and references therein).

Another source of background ionization can be leftover ionization from previous discharges. This is especially important in repetitive discharges types like DC corona discharges or repetitive pulsed discharges. Already at a slow repetition rate of about 1 Hz, leftover charges can lead to background ionization densities of order 10^{13} m^{-3} [2]. Background ionization can also be created by external UV-radiation sources, x-ray sources, addition of radioactive compounds to the gas or surfaces, electron or ion beam injection and more.

Independently of the source of background ionization, in air the created electrons will always quickly attach to oxygen. This means that they will have to be detached by the high field of the streamer before they can be accelerated and form avalanches.

We have used both methods to test for the effects of background ionization on positive streamers: we have added traces of radioactive ^{85}Kr to pure nitrogen to increase background ionization levels and we have varied the pulse repetition frequency of discharges in pure nitrogen. (Purity is defined below in Table 1.)

2. Experimental methods

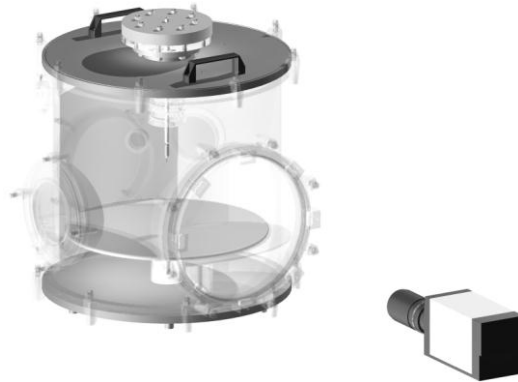

Figure 1. Overview of the vacuum vessel with the ICCD camera. The wall of the vessel has been rendered transparent in the figure to make the anode tip and cathode plane clearly visible.

We have built a set-up that is specifically designed to ensure the purity of the enclosed gasses. For this reason, the set-up can be baked to reduce outgassing, it contains no plastic parts, except for the o-ring seals and it stays closed all the time. We have used this set-up with three different gas mixtures. They are specified in table 1.

Table 1. Gas composition and impurity levels of relevant gasses as provided by the gas supplier. Impurity levels are in parts per million (ppm). They are given as upper limits, except for ^{85}Kr , which is dosed on purpose in the nitrogen/krypton mixture.

Gas	N_2	O_2	^{85}Kr	H_2O	Other
Artificial Air	80%	20%	n/a	0.5	0.5
Pure Nitrogen	100%	0.03	n/a	0.05	0.1
Nitrogen/Krypton	100%	0.5	0.0099	0.5	8

The vacuum vessel contains a sharp tungsten tip, placed 16 cm above a grounded plane. The vacuum vessel with the camera is sketched in figure 1.

We have employed two pulsed power sources to provide the high voltage pulses required for streamer initiation. These two power supplies are a so-called C-supply and a Blumlein pulser. The C-supply consists of a capacitor that is discharged by means of a sparkgap and thereby creates a voltage pulse with exponential rise and decay. In our measurements with the C-supply rise times are typically of the order 100 ns and decay times are of order 5 μs . More details about the C-supply can be found in [5]. The Blumlein pulser consists of two ten meter long coaxial cables that are charged and then discharged by means of a multiple sparkgap. This creates a more or less rectangular voltage pulse

with a duration of about 130 ns and a risetime of about 10 ns. This circuit is treated in more detail in [3].

The streamer discharge is imaged by a Stanford Computer Optics 4QuickE ICCD camera. In the images presented here, the original brightness is indicated by the multiplication factor Mf, similar to what Ono and Oda introduced in [6] and as described by us in [3]. We have normalized the Mf value in such a way that the brightest image presented in [3] has an Mf value of 1.

More information about the circuit, discharge vessel and imaging system can be found in [3, 7, 8].

3. Results

3.1 General overview

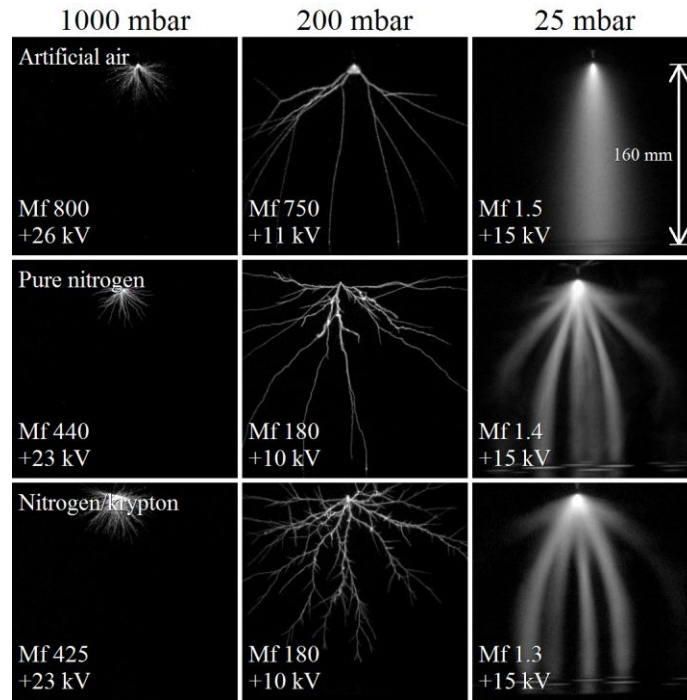

Figure 2. Overview of streamer discharges produced with the C-supply for our three gas mixtures (rows), at pressures of 1000, 200 and 25 mbar (columns) and 1 Hz repetition frequency. All measurements have a long exposure time and therefore show one complete discharge event, including transition to glow for 25 mbar. The multiplication factor (Mf) gives an indication of the real intensity of the discharge. The length scale is indicated with the arrow at the top right. Measurements in artificial air and nitrogen were previously published in [3].

Overview images of streamer discharges in the three different gasses are shown in figure 2. It shows that there are some differences in appearance between the gasses, but they are limited. When comparing artificial air and pure nitrogen we can see that even with a change of more than six orders of magnitude in oxygen content, streamer length and appearance remain more or less the same, as was already shown in [3]. At 25 mbar there seems to be a clear distinction between artificial air and pure nitrogen. However, with a few kilovolts higher pulse, both gasses will show the same morphology (one single streamer). When zooming in, or when using pulses from the Blumlein pulser, more differences between pure nitrogen and artificial air become apparent. Most notable is the fact that in pure nitrogen the streamers get a feather-like appearance. We attribute this to the lower density of electrons or negative ions produced by photo-ionization in front of the streamer head. This leads to a more stochastic distribution of these electrons and therefore to single (visible) avalanches and/or more easy breakup of the streamer head and thus to more branching. This is shown and discussed in more detail in [3, 9].

When adding a small amount of radioactive krypton to pure nitrogen (note that its purity is somewhat less than of the pure nitrogen above), the background ionization is increased by secondary ionization from the emitted beta particles of ^{85}Kr decay (half-life 10.756 years, decay by a 251 keV average energy β -particle). The 9 parts per billion of ^{85}Kr in our mixture lead roughly to an additional background ionization level of $2 \cdot 10^{12}$, $4 \cdot 10^{11}$ and $1 \cdot 10^{10} \text{ m}^{-3}$ at 1000, 200 and 25 mbar respectively.

At 25 and 1000 mbar the discharges in the nitrogen/krypton mixture are quite similar to the pure nitrogen discharges. At 200 mbar some differences are visible: the streamers in the nitrogen/krypton mixture branch more and do not reach the other side.

3.2 Effects of pulse repetition frequency

A second way of influencing the background ionization levels is to vary the pulse repetition frequency. Even though the frequencies we used (0.01-10 Hz) are very slow compared to plasma reactions like recombination, some leftover ionization can remain because the ionization levels within a streamer are about 10 orders of magnitude higher than background ionization levels in virgin air.

The effect of repetition frequency on streamer morphology in pure nitrogen is shown in the top row of figure 3, where there is a distinct difference between streamers in pure nitrogen made with the same pulse shape but at 10, 1 and 0.1 Hz pulse repetition frequency. At higher frequencies, the streamers are smoother and fewer or no feather-like structures are visible. Streamers in the nitrogen/krypton mixture show a somewhat similar trend, although in this mixture the streamers remain much smoother at 0.1 and 1 Hz than the ones in pure nitrogen. The smoothness of the streamer channels has been quantified by counting the number of irregularities per unit length of streamer channel. All visible irregularities have been counted including feathers, branching events and sudden turns. Results of this counting are shown in figure 4.

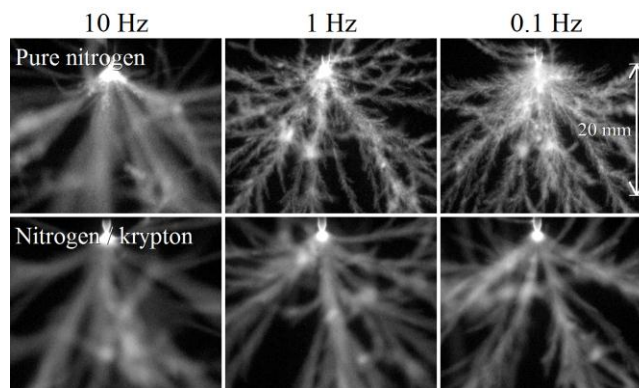

Figure 3. Zoomed images around the cathode tip of repetitive streamer discharges created with the Blumlein pulser (pulse length 130 ns) at 25 kV at three different pulse repetition frequencies in pure nitrogen and the nitrogen/krypton mixture.

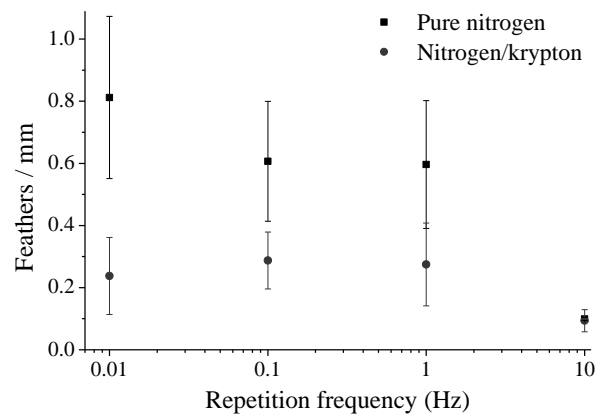

Figure 4. Feather density as function of repetition frequency in pure nitrogen and in the nitrogen/krypton mixture. Measurements are performed on discharges under the same conditions as shown in figure 3, but on channels extending further from the tip, outside the visible areas of figure 3 (to ensure a clean view of the channel). The measured values are the number of visible bumps, feathers, branches and all other irregularities per mm of streamer length and are not corrected for projection effects. The error bars give the standard deviation of the measurements.

The quantitative results confirm the observations from the images that streamers become smoother at higher repetition frequencies and that at repetition frequencies below 10 Hz, the streamers in the nitrogen/krypton mixture are smoother than the ones in pure nitrogen.

4. Discussion and conclusions

The background ionization levels left by previous discharges at 200 mbar and 1 Hz in pure nitrogen are estimated as about 10^{12} m^{-3} in [2]. In this calculation, an effective recombination rate of $5 \cdot 10^{-7} \text{ cm}^3 \text{ s}^{-1}$ was used. This calculation will be an overestimate as it assumes a homogeneous distribution of leftover ionization of 10^{20} m^{-3} while in fact such levels are only obtained within a streamer channel and the channels fill only a small percentage of our vessel. Therefore, a more realistic estimate is about one order of magnitude lower. This brings the value just below the estimate of the background ionization from radioactive decay in the nitrogen/krypton mixture ($4 \cdot 10^{11}$ at 200 mbar).

The estimated ionization levels due to repetition or radioactivity agree around 1 Hz; this fits well with the observed behaviour that shows differences in streamer morphology between pure nitrogen and nitrogen/krypton at 1 Hz and lower repetition frequencies, but no differences at 10 Hz. At the lower frequencies the (fixed) radioactive ionization source dominates over the ionization from previous discharges, while at 10 Hz the leftover ionization is dominant.

Note that the nature of the ionization can vary between the two ionization mechanisms. In leftover ionization, only ions exist, as all free electrons will have attached to oxygen impurities (even at low oxygen concentrations). However, with radioactive ionization, there is a constant source of free electrons. Some of them will have attached to oxygen, but the ones produced shortly before the voltage pulse will still be free. Such free electrons can more easily produce an avalanche as they don't need to be detached from negative ions by a high field.

In general we do not observe large differences in streamer properties between air, pure nitrogen and the nitrogen/krypton mixture or between different repetition frequencies. Minimal streamer diameters and propagation velocities are very similar even though photo- and background ionization vary many orders of magnitude. This confirms that streamers are very insensitive for the exact value of photo- and background ionization levels as was already discussed in [2, 3]. The observations also confirm the explanation of feather-like structures in streamers given in these papers. Again, it is found that higher ionization levels (photo or background) lead to smoother streamers and less feathers. This supports the theory that the feathers are caused by the stochastic nature of the ionization distribution that occurs at low ionization levels and that the feathers may be visible remnants of single avalanches.

5. References

- [1] S. Pancheshnyi, M. Nudnova and A. Starikovskii. *Development of a cathode-directed streamer discharge in air at different pressures: Experiment and comparison with direct numerical simulation*. Phys. Rev. E **71**, 016407 (2005).
- [2] G. Wormeester, S. Pancheshnyi, A. Luque, S. Nijdam and U. Ebert. *Probing photo-ionization: Simulations of positive streamers in varying N₂:O₂-mixtures*. J. Phys. D: Appl. Phys. **43**, 505201 (2010).
- [3] S. Nijdam, F. M. J. H. van de Wetering, R. Blanc, E. M. van Veldhuizen and U. Ebert. *Probing photo-ionization: Experiments on positive streamers in pure gases and mixtures*. J. Phys. D: Appl. Phys. **43**, 145204 (2010).
- [4] A. Luque, U. Ebert and W. Hundsdorfer. *Interaction of Streamer Discharges in Air and Other Oxygen-Nitrogen Mixtures*. Phys. Rev. Lett. **101**, 075005 (2008).
- [5] T. M. P. Briels, J. Kos, E. M. van Veldhuizen and U. Ebert. *Circuit dependence of the diameter of pulsed positive streamers in air*. J. Phys. D: Appl. Phys. **39**, 5201 (2006).
- [6] R. Ono and T. Oda. *Formation and structure of primary and secondary streamers in positive pulsed corona discharge--effect of oxygen concentration and applied voltage*. J. Phys. D: Appl. Phys. **36**, 1952-1958 (2003).
- [7] T. M. P. Briels, J. Kos, G. J. J. Winands, E. M. van Veldhuizen and U. Ebert. *Positive and negative streamers in ambient air: measuring diameter, velocity and dissipated energy*. J. Phys. D: Appl. Phys. **41**, 234004 (2008).
- [8] S. Nijdam, C. G. C. Geurts, E. M. van Veldhuizen and U. Ebert. *Reconnection and merging of positive streamers in air*. J. Phys. D: Appl. Phys. **42**, 045201 (2009).
- [9] G. Wormeester, S. Nijdam and U. Ebert. *Feather-like Structures in Positive Streamers*. Revised for: Jpn. J. Appl. Phys. (2011).