

Analysis and synthesis of environmental sounds

Citation for published version (APA):

Guggiana, V., Darvishi, A., & Rauterberg, G. W. M. (1995). *Analysis and synthesis of environmental sounds*. (Technical report; Vol. 95.12). Swiss Federal Institute of Technology.

Document status and date:

Published: 01/01/1995

Document Version:

Publisher's PDF, also known as Version of Record (includes final page, issue and volume numbers)

Please check the document version of this publication:

- A submitted manuscript is the version of the article upon submission and before peer-review. There can be important differences between the submitted version and the official published version of record. People interested in the research are advised to contact the author for the final version of the publication, or visit the DOI to the publisher's website.
- The final author version and the galley proof are versions of the publication after peer review.
- The final published version features the final layout of the paper including the volume, issue and page numbers.

[Link to publication](#)

General rights

Copyright and moral rights for the publications made accessible in the public portal are retained by the authors and/or other copyright owners and it is a condition of accessing publications that users recognise and abide by the legal requirements associated with these rights.

- Users may download and print one copy of any publication from the public portal for the purpose of private study or research.
- You may not further distribute the material or use it for any profit-making activity or commercial gain
- You may freely distribute the URL identifying the publication in the public portal.

If the publication is distributed under the terms of Article 25fa of the Dutch Copyright Act, indicated by the "Taverne" license above, please follow below link for the End User Agreement:

www.tue.nl/taverne

Take down policy

If you believe that this document breaches copyright please contact us at:

openaccess@tue.nl

providing details and we will investigate your claim.

Analysis and Synthesis of Environmental Sounds

Authors:

Valentin Guggiana, Alireza Darvishi, Eugen Munteanu, Helmut Schauer
Department of Computer Science (IfI), University of Zürich,
Winterthurerstrasse 190, CH-8057 Zürich, Switzerland

Masoud Motavalli

Swiss Federal Laboratories for Material Testing and Research (EMPA)
Überlandstrasse 129, CH-8600 Dübendorf, Switzerland

Matthias Rauterberg

Usability Laboratory, Work and Organizational Psychology Unit
Swiss Federal Institute of Technology (ETH), Nelkenstrasse 11, CH-8092 Zürich,
Switzerland

Tel: +41-1-632 7082, email: rauterberg@rzvax.ethz.ch

Abstract

This technical report describes steps toward synthesis of environmental sounds like impact, bouncing, breaking, scraping and other impact sounds. The first section shows by means of knowledge engineering the investigation of possible methodologies and techniques for developing and describing environmental sounds in the industry. The second section describes various laboratory experiments which have been carried out in an anechoic room, impacting beams and plates of different materials. This is followed by physical modelling of the interacting objects which are involved in the sound generation. The synthetically generated and recorded sounds were used for comparison and for deriving data for further analysis. Hence physical modelling of sounds could be examined through data analysis and adjusted if necessary. Some developed algorithms for analysing impact sounds as well as some developed algorithms for sound synthesis are introduced later.

Psycho acoustical comparison tests will soon be carried out, and will allow us to test the quality of generated sounds and to gain more knowledge about the perception of environmental sounds in general.

Knowledge Engineering

In order to define relevant parameters and possibilities for describing environmental sounds, we were concentrating on the following knowledge engineering techniques:

- interviewing experts
- accompanying sound designers during their work
- analysing sounds in film documents

Interviewing Experts

In the last years many automobile and household technology companies have established new departments for modelling and designing sounds, i.e. sound engineering departments. They are using modern workstations for analysing, manipulating and generating sounds. In order to achieve certain sound effects with cars (e.g. sporty, engine power), different types of sounds inside the automobile and the sounds of wheels and motor are being analysed and manipulated. Thus, the latest knowledge of psycho acoustics is being applied.

The main idea of doing these interviews was to explore concepts and find possible parallels between sound design in those domains and human-computer interfaces. Listed below are the most important companies, University departments and their contact persons, that we visited:

- BMW (cars), München: Mr. Tonhauser (Department of Sound Engineering)
- VW (cars), Wolfsburg: Dr. Müller (Department of Acoustics)
- Cortex (Acoustic Workstations), Regensburg: Prof. Dr. Zollner
- Head Acoustics (Sonometers), Herzogenrath: Mr. Schmeisser
- TU München (Institute for Human-Computer Communication): Prof. Dr. Fastel
- University of Oldenburg (Physics Department): Dr. Reinert Weber

Observing Sound Designers During Their Work

At the Sound Exhibition in Basel (Switzerland) in summer 1994 two famous sound designers demonstrated their methods and techniques in sound simulation for film production. We interviewed them both about their tools and techniques for sound synchronisation in films and radio plays.

Analysing Existing Film Documents

We watched and analysed a film from a German television channel about sound design techniques and synchronisation. The film introduces the job of a sound designer in detail.

Results

Our investigations and observations were not very relevant to our research project. Formal descriptions of everyday sounds by attributes or typical adjectives are very difficult for sound designers. The design of sounds in the automobile and household technology industry are both very different from sound design aspects in our research project.

Sound engineering in those domains aims mainly at manipulating sounds in order to achieve specific sound effects. It does not aim at defining methods for a formal representation of sound. In contrast, the scope of our research project is to define new algorithms for the automatic generation of environmental sounds. We also try to describe environmental sounds in the German language from a linguistic point of view.

Experiments

At the EMPA Dübendorf (Switzerland) we have carried out experiments in an anechoic room with beams and plates made of various materials and with different shapes. Various spheres were dropped from different heights onto plates and beams and the resulting sounds were recorded on a DAT tape. The digital recordings have an excellent quality for further processing.

Through various combinations 252 different sounds were generated for analysis and later comparison:

$$3 \text{ heights} \cdot 7 \text{ spheres} \cdot 6 \text{ materials} \cdot (\text{plate} + \text{beam}) = 252 \text{ sounds}$$

Figure 1 illustrates schematically the equipment for our laboratory experiments. Table 1 and 2 list the properties of the objects involved, which build the basis for our calculated sounds.

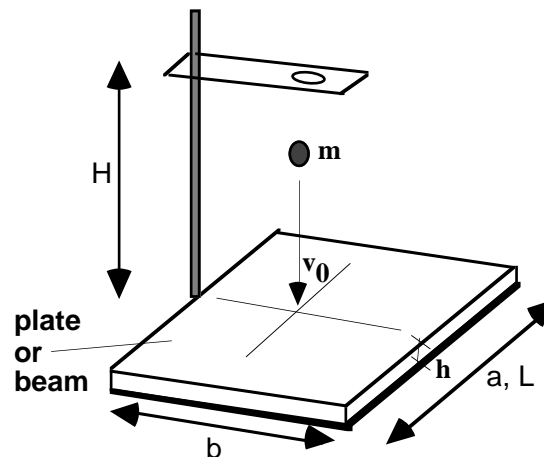

Figure 1: laboratory equipment

name	g	s1	s2	s3	s4	s5	s6
material	glass	steel	steel	steel	steel	steel	steel
diameter [mm]	14.1	7.5	8.0	9.0	10.0	12.0	14.0

mass [g]	3.65	1.72	2.09	2.98	4.07	7.02	11.16
----------	------	------	------	------	------	------	-------

Table 1: spheres

material	plate diameter [mm]	beam diameter [mm]	density [kg/m ³]	poisson-coefficient	elasticity [GPa]
aluminium	3.98	3.98	2700	0.33	71.0
glass	7.94	7.94	2300	0.24	62.0
wood	8.06	8.06	720	0.30	5.0
Plexiglas	3.80	3.90	1180	0.30	3.3
PVC	6.00	6.12	1390	0.38	3.9
steel	2.96	2.96	7700	0.28	195.0

Table 2: plates and beams

Physical Modelling

The Approach

A qualitative analysis of impact sounds shows that they decrease in intensity exponentially. Theoretical considerations and real sound analysis lead us to a system of damped natural modes of vibration with various initial amplitudes. However, this approach only applies to certain materials, those which are homogeneous and non dispersive. A formal description for the approach is :

$$u = \sum A_0 \cdot e^{-\delta t} \cdot e^{i\omega t}$$

u displacement
 A₀ initial amplitude
 δ damping
 ω eigen-frequency
 t time

Eigen-Frequencies

The eigen-frequencies (natural frequencies) of each object depend on its material properties and its geometric shape. With respect to the above mentioned conditions, the elasticity modulus and the Poisson coefficient are encountered within the formula. The formula allows a direct description of simple geometric forms like plates and beams. Complex geometric forms however, require intensive numeric calculations. In any case, the formula remains scalable, which means that changing one instance results in a linear change in the overall result. The next formula for a clamped beam shows this:

$$f_n = \frac{n^2 \pi h}{L^2} \sqrt{\frac{E}{3\rho}}$$

f_n n-th eigen-frequency
 E elasticity
 ρ density
 L length
 h diameter
 n number of eigen-frequency

Initial Amplitude / Excitation

Research by Koller [K], based on previous work by Zener [Z] investigates the motion of impact force. Analyses of that force lead to the spectrum of excited natural frequencies. The impact time is too short, so that results range within the spectral uncertainty :

$$\Delta\omega \cdot \Delta t \geq 1, \text{ with } \Delta t \cong 40\mu\text{s}, \text{ thus } \Delta\omega \cong 25\text{kHz}$$

The spectral range which can be perceived by humans, resides between 20 Hz and 20 kHz; human sensitivity decreases with higher age. Hence, the influence of the impact force on the initial spectrum can be ignored.

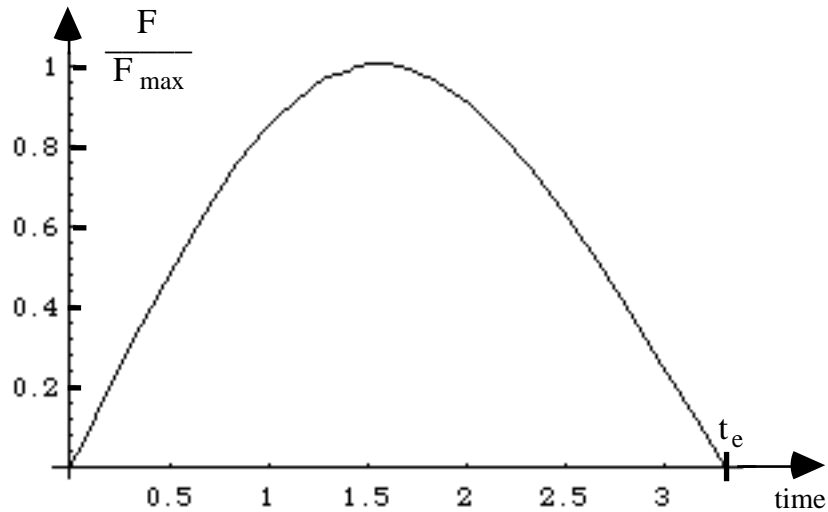

Figure 2: Impact force

Nevertheless, the exact location where the impact force strikes has a great influence on initial amplitudes. Obviously, an impact force applied on a node of a natural frequency does not excite the respective modes of vibration. On the contrary, when the sphere strikes right in the peak of an eigen frequency wave, this mode will be fully excited.

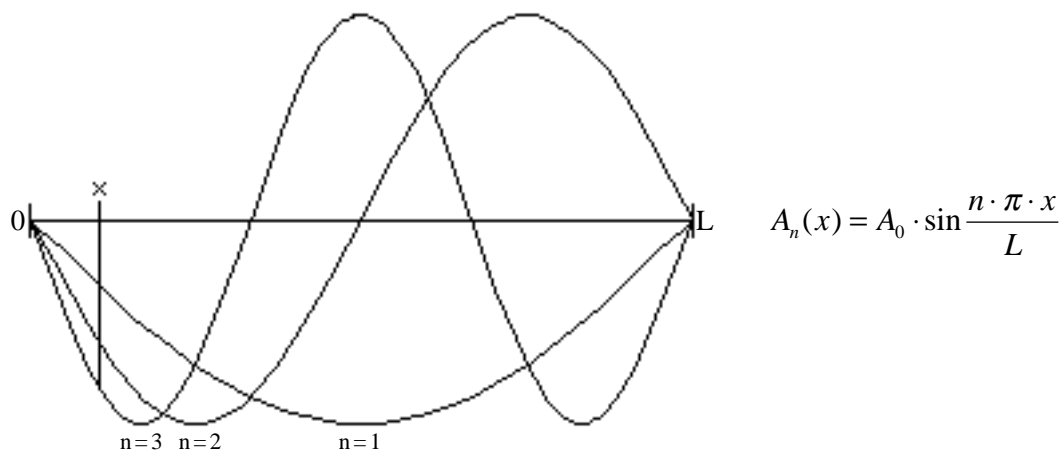

Figure 3: Excitation localisation

The above explanations consider only relative amplitudes of different frequencies among each other. Even though it is possible to calculate the absolute amplitudes as well, what we really hear is also dependent on the distance from sound source. Therefore, we consider only the relative initial amplitudes and their evolution related to the impact point.

Damping

One can distinguish two kinds of damping for real sounds: intrinsic and system damping.

The intrinsic damping results from the material's internal friction. It is possible to calculate intrinsic damping by the complex elasticity modulus for various materials [W]:

$$\delta = \omega \cdot \tan \phi \quad M = \mathbf{M}(1 + i \cdot \tan \phi)$$

δ damping
 ω frequency
 ϕ phase between strain and stress
 M complex elasticity modulus
 \mathbf{M} real part of elasticity modulus

Typical events where intrinsic damping is much more important than system damping are: vibrating strings, tuning-forks and bells.

System damping is very important when additional (boundary) conditions exist and the whole system undergoes damping. Window panes, doors and tables are typical examples from daily life. A precise mathematical calculation of system damping is impossible, so experimented values and empirical formulas are called for.

Analysis

The results of our experiments supply the parameter set (A_0, δ, ω) , which are relevant for our approach. In the following three paragraphs we will describe the applied algorithms.

Eigen Frequencies

Fourier transformation is applied to the whole length of the sound in order to obtain the best frequency resolution. This results in a loss of time resolution, but it does not matter, as time is of no particular importance for this demand. Sound's duration of course depends on the damping of different frequencies. In our measurements the duration fluctuates between 15 ms and 30 ms. Therefore, the frequency resolution ranges between 6 Hz and 63 Hz. By precise segregation of different frequencies it is even possible to have a higher resolution by using the method of the smallest square. One can demonstrate this approach nicely, by generating synthetic signals. As the human ear is very sensitive to comparing the frequencies of different sounds, we can easily justify an additional effort for this approximation.

Initial Amplitude / Excitation

The initial amplitude of a sound can be calculated from a short fragment from the beginning of sound. After having determined a frequency, it is easy to calculate the initial amplitude precisely. However it is important to notice that through transformation a time interval is integrated. Accordingly, the amplitude is not related to a specific time but to a time interval. Hence, the correction factor k , can be calculated for $A_t = k A_{\Delta t}$ as follows:

$$k = \frac{\Delta t}{\int_0^{\Delta t} e^{-\delta \cdot t} dt} \Rightarrow k = \frac{\delta \cdot \Delta t}{1 - e^{-\delta \cdot \Delta t}}$$

Figure 4: Initial amplitude

Damping

Parameter δ of damping can be calculated from two amplitudes at different times. The precision can be increased, the more successive amplitudes per time are considered.

The sound is divided in multiple parts, which may overlap. Through Fourier transformation it is possible to calculate a designated amplitude for any frequency which relates to a specific time interval. This amplitude $A(t)$ is

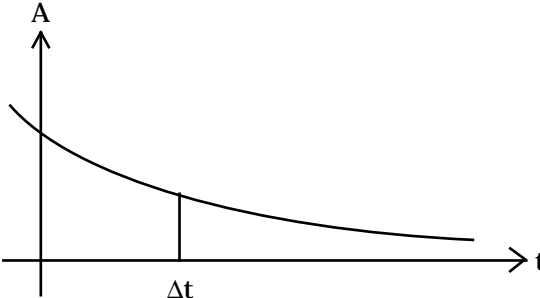
corrected by the same factor which was mentioned above in order to have the amplitude for a certain time. δ is derived as follows:

$$A(t) = A_0 \cdot e^{-\delta \cdot t} \Rightarrow \delta = \frac{-\ln \frac{A(t)}{A_0}}{t}$$

We have divided the signals into 32 parts and each part has 512 samples in order to minimise the time overlay of parts and yet have enough frequency resolution.

These values describe the overall damping. Unfortunately, a distinction between intrinsic and system damping is not possible as the derived information from analysed data does not contain any information about the original materials.

Limitations / Problems

The investigation showed that such analysis offers good results if eigen-frequencies are separated clearly enough. This is the case for homogeneous materials like metals, glass and synthetic materials. Unfortunately this is not the case for wood or similar materials which consist mainly of fibres, especially if these fibres are not strictly directed. In order to model these materials we have to take into account their dispersive characteristics as well as the different behaviour along axis.

Synthesis

Real time behaviour plays a mayor role in sound synthesis. For user-interface applications synthesised sounds need to be made in real time. The two techniques of sound synthesis, which are described below, can be also efficiently implemented in silicon to exploit the parallelism of the algorithms.

Additive Synthesis

The technique of additive synthesis reflects our approach for which the formula was already given above. It is possible to implement an efficient and fast algorithm by using the Euler formula. Real time behaviour is only limited by the amount of generated frequencies. The simplicity of this technique has many advantages as well as disadvantages. The advantage lies in the controllability of the results, which always fulfil expectations, but its power is quite restricted. However, this technique is well suited for testing and generating synthetic sounds.

Filter Bank

In contrast to the additive synthesis this technique is an extractive one. With some white noise as input, only some frequency bandwidth is able to pass through the filter. Some parallel filters, so-called filter banks are used. The transfer characteristic of this filter is derived from material properties and the geometry of sound producing objects. The advantages of this technique are that the transfer characteristic can be controlled in time and there are a large number of parameter choices. It allows the generation of more complex impact sounds, like rolling, rubbing or breaking.

Psycho Acoustical Tests for Comparison

During our project we also developed a software tool for comparison tests which allows multiple people to listen and classify a set of sounds in random order. By using statistical methods we have analysed the test results, i.e. the classified

sounds to judge their quality. This helps us to decide on the suitability and the problems of our approach.

Another very useful side benefit of this project, which should not be underestimated, is the gain of important insight about human hearing and perception capabilities.

Appendix

Developed Tools

- Sample Editor: 8, 16 and 32-bit samples; mono, stereo; can be extended dynamically:

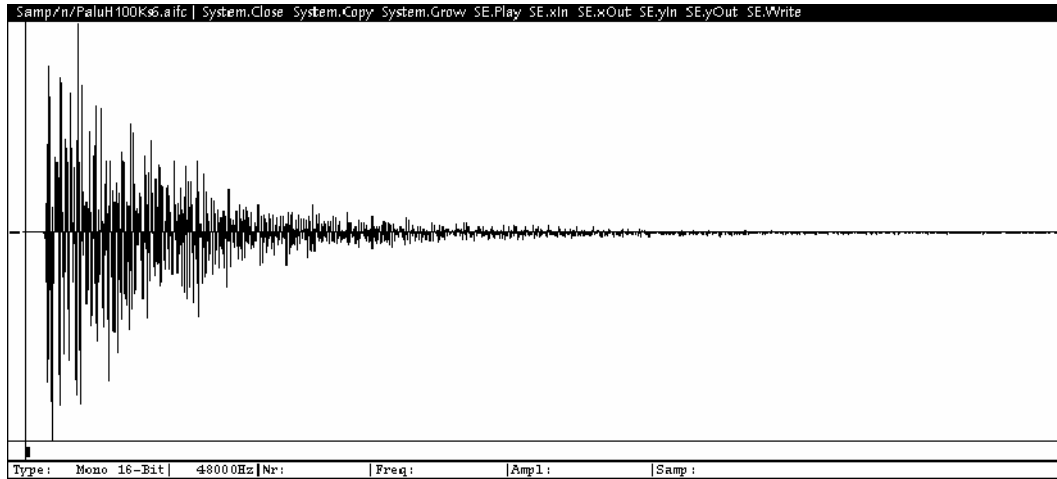

- visualisation of spectrograms (with grey levels or three dimensional relief):

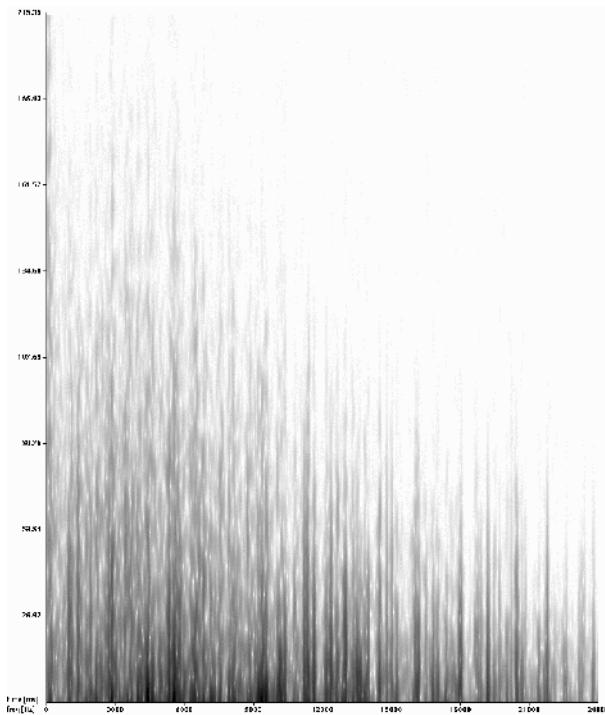

- numeric integration of differential equations
- Fourier analysis and synthesis
- generation of sounds with additive synthesis and filter bank
- device independent in- and output of sounds (portability!)
- automatic analysis of impact sounds

- mathematical calculation of impact sounds behind the graphical user interface:

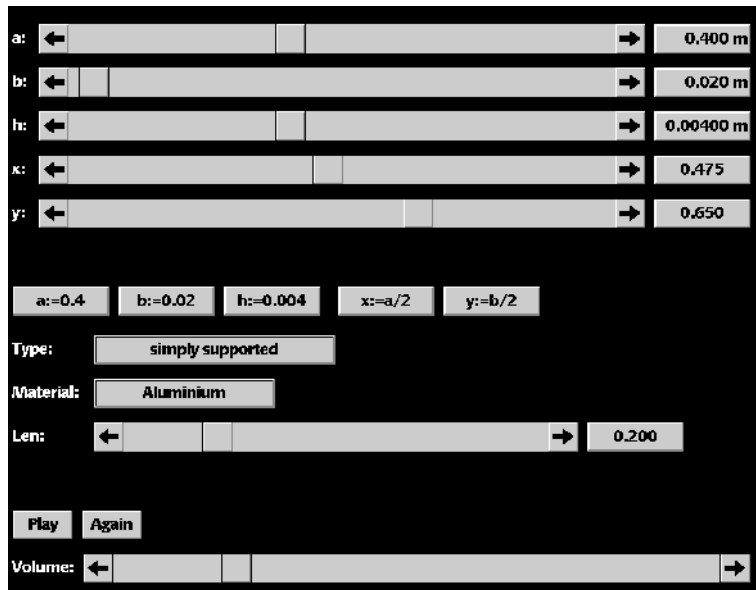

- user interface for psycho acoustical comparison test:

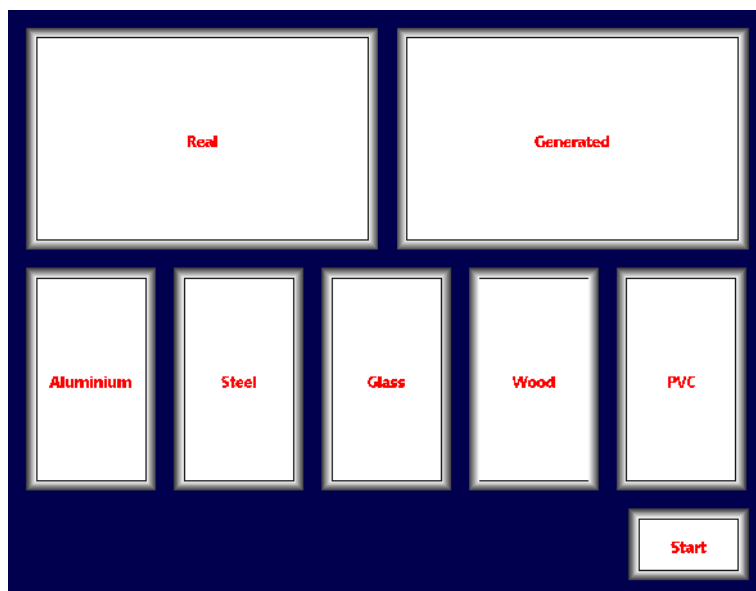

References

- [K] M. Koller, Elastischer Stoss von Kugeln auf dicke Platten, Diss. ETH Nr. 7299
- [Q] Quantics, Rudiments of Quantum Physics, Lévy-Leblond & Balibar, North-Holland
- [W] R. Wildes, W. Richards, Recovering Material Properties from Sound, Natural computation, Cambridge, MA, MIT Press, 1988
- [Z] C. Zener, Phys. Rev. 59, 669 (1941)