

The concept of the habit plane and the phenomenological theories of the martensite transformation

Citation for published version (APA):

Klostermann, J. A. (1972). The concept of the habit plane and the phenomenological theories of the martensite transformation. *Journal of the Less-Common Metals*, 28(1), 75-94. [https://doi.org/10.1016/0022-5088\(72\)90170-1](https://doi.org/10.1016/0022-5088(72)90170-1)

1

DOI:

[10.1016/0022-5088\(72\)90170-1](https://doi.org/10.1016/0022-5088(72)90170-1)

Document status and date:

Published: 01/01/1972

Document Version:

Publisher's PDF, also known as Version of Record (includes final page, issue and volume numbers)

Please check the document version of this publication:

- A submitted manuscript is the version of the article upon submission and before peer-review. There can be important differences between the submitted version and the official published version of record. People interested in the research are advised to contact the author for the final version of the publication, or visit the DOI to the publisher's website.
- The final author version and the galley proof are versions of the publication after peer review.
- The final published version features the final layout of the paper including the volume, issue and page numbers.

[Link to publication](#)

General rights

Copyright and moral rights for the publications made accessible in the public portal are retained by the authors and/or other copyright owners and it is a condition of accessing publications that users recognise and abide by the legal requirements associated with these rights.

- Users may download and print one copy of any publication from the public portal for the purpose of private study or research.
- You may not further distribute the material or use it for any profit-making activity or commercial gain
- You may freely distribute the URL identifying the publication in the public portal.

If the publication is distributed under the terms of Article 25fa of the Dutch Copyright Act, indicated by the "Taverne" license above, please follow below link for the End User Agreement:

www.tue.nl/taverne

Take down policy

If you believe that this document breaches copyright please contact us at:

openaccess@tue.nl

providing details and we will investigate your claim.

THE CONCEPT OF THE HABIT PLANE AND THE PHENOMENOLOGICAL THEORIES OF THE MARTENSITE TRANSFORMATION*

J. A. KLOSTERMANN

Twente Technological University, Enschede (The Netherlands)

(Received January 18th, 1972)

SUMMARY

Three different interpretations of a martensite habit plane are in use: (a) the plane of the plate of a plate-shaped crystal, (b) a semi-coherent plane glissile interface, (c) the plane boundary of a plate shaped product. These are not necessarily the same: for surface martensite they are different.

Several recent "generalized theories" of martensite transformation did not succeed in explaining the experimental observations on martensite of the {252}-type in a satisfying way. Results of observations on surface martensite in Fe-30 wt. % Ni are, among others:

(1) an orientation relationship, very close to the orientation predicted by the I.P.S. theory for the same alloy. The habit plane, however, is not the predicted (3, 15, 10) plane, but the (121) plane.

(2) A direction of the shape deformation predicted by a Frank type of matching.

These results, together with the recent observation of bend faults in martensite of the (252) type, indicate that the transformation takes place in at least two stages. Therefore, a "generalized theory of martensite transformation", which tries to predict the whole transformation (conceived as one single process) assuming a set of lattice invariant shears will, perhaps, never be very successful, because the transformation can proceed in different stages involving rather complex shears.

INTERPRETATIONS OF THE CONCEPT HABIT PLANE

The concept habit plane can be interpreted in several ways. Perhaps much confusion will be avoided if a clear distinction between several possibilities is made. Interpretations of the concept habit plane are:

(1) The plane of the plate of a plate-shaped crystal of the transformation product. This is the classical view and we propose to maintain this. (We will use it in this sense unless otherwise stated.) If the boundaries of the plate deviate from the overall orientation of the plate, a midrib is often chosen for the habit plane. It is an interesting question to ask what we should expect to see if we could follow the growth of a martensite plate by looking in a perpendicular direction to it during its growth.

* Dedicated to Professor Dr. W. G. Burgers in celebration of his 75th birthday.

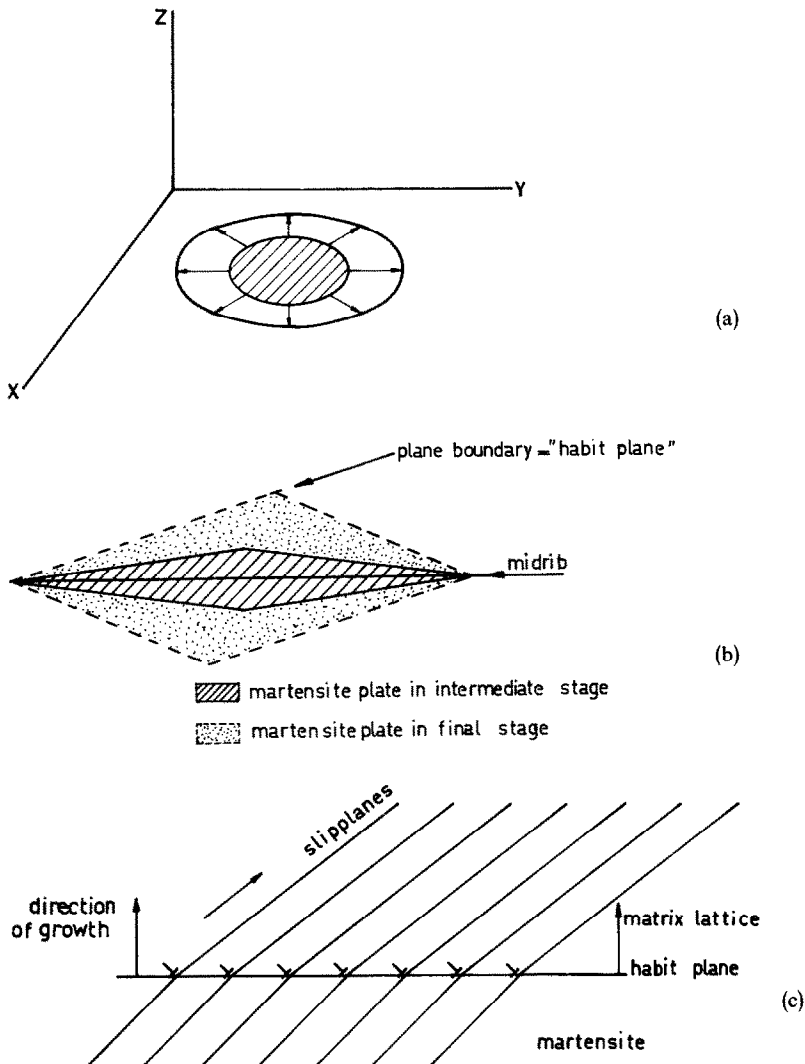

Fig. 1. (a) Formation of a habit plane by the expansion of dislocation loops which perform the transformation on a few lattice planes. (b) Habit plane as a plane interface which is formed by growth in the transverse direction. Relatively immobile interfaces or interfaces with low energy will form in this way (*cf.* the habit plane of a plate-shaped crystal which is formed from a supersaturated solution). (c) A semi-coherent glissile interface. If the dislocations move along the slip planes, in the direction indicated with an arrow, the matrix lattice is transformed to martensite.

Figure 1(a) demonstrates a possibility of the formation of a habit plane in the sense mentioned above. An expansion of a set of dislocation loops performs the transformation on a few lattice planes. An example is given by the transformation f.c.c. \rightarrow h.c.p. in cobalt. The loops are in this case partial dislocations of the type $a/6 \langle 112 \rangle$ moving on $\{111\}$ planes and the habit plane is the track traced behind by the dislocation loops.

(2) Another interpretation of the habit plane is the plane boundary¹ of a plate-shaped transformation product. Figure 1(b) shows, schematically, how a plane inter-

face can be formed by growth in the transverse direction. The plane interface can originate in several ways, *i.e.*, because the interface finally formed is relatively immobile or is an interface of best fit, respectively, of low energy*. Plane interfaces of this type are formed by surface martensite and angle profile martensite².

(3) A third interpretation is that of a semi-coherent plane interface (glissile interface). By the movement of this interface the transformation is performed. In Fig. 1(c) such an interface is indicated schematically.

In fact the glissile interface and the habit plane of a plate-shaped crystal in the classical sense are not necessarily the same. However, in certain cases, for instance in the case of the transformation of a single crystal of Au-50 at.% Cd, a plane boundary between the transformed and the untransformed region can be observed³. This boundary can probably be interpreted as a semi-coherent interface. Accidentally, this semi-coherent plane interface is, at the same time, the plane of plate-shaped transformation products which can be formed in this alloy. However, the possibility cannot be excluded that for one and the same martensite crystal the habit planes, according to the three interpretations, are physically all different. In the large martensite plate of Fig. 2 (formed in Fe-28 wt.% Ni), for instance, the midrib is the track traced behind by some loop or shock wave** (Fig. 1(a)).

Growth in the transverse direction of the plate may be performed by a semi-coherent boundary, described in Fig. 1(c). It is even possible that, although this semi-

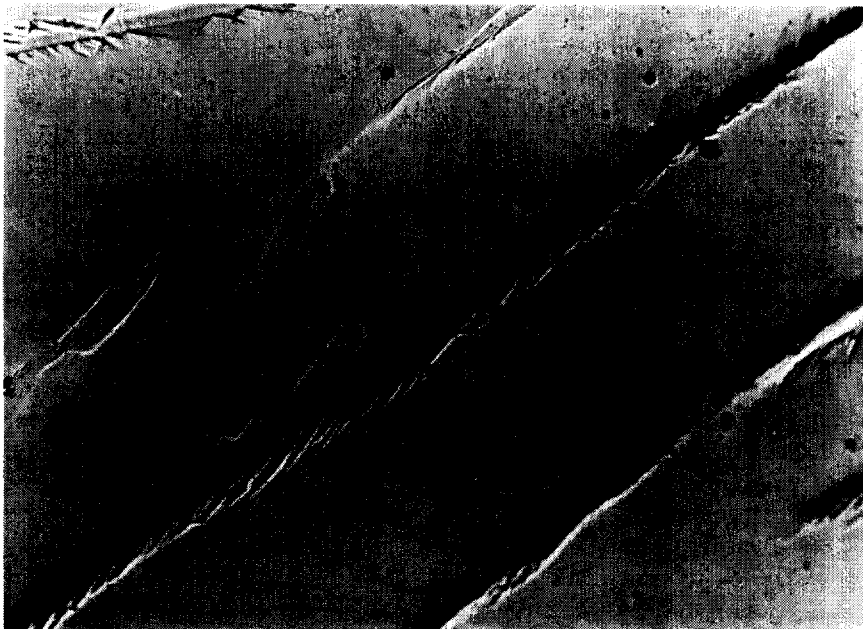

Fig. 2. Plate of martensite formed in Fe-28 wt.% Ni. ($\times 540$)

* Compare interfaces formed on a plate-shaped crystal, which is grown from a super-saturated solution. In this case, the planes of the plate are the most slowly moving planes.

** At this point we may again draw attention to the fact that nearly nothing is known of the mechanism by which the habit plane in fact originates.

coherent interface has the same orientation as the plane of the midrib, the mechanisms by which both are formed are different. The straight boundaries visible on the plate of Fig. 2 may be formed in the end in the way indicated by Fig. 1(b).

THE PHENOMENOLOGICAL THEORIES

The so-called phenomenological theories of martensite transformation, developed by Wechsler, Liebermann and Read⁴ and Bowles and Mackenzie⁵, have been applied with undeniable success in several cases. These theories differ only in their mathematical formulation but are essentially the same. Together they are also named the invariant plane strain (I.P.S.) theory, despite the introduction of an isotropic dilatation on the interface in the calculations, as first proposed by Bowles and Mackenzie. The theories intend to correlate the crystallographic features of martensite; habit plane, shape deformation, orientation relation and magnitude of the lattice invariant deformation; or even to predict them assuming a lattice correspondence and a plausible plane and direction, of a lattice invariant deformation. The habit plane is supposed to be an invariant plane or to differ from it by a small isotropic dilatation δ . For instance, in the case of Fe-24.5% Pt, Efsic and Wayman⁶ found that the experimental results agreed to a high degree of accuracy with those predicted by the I.P.S. theory, with a dilatation parameter $\delta \approx 1$, that is, (nearly) zero dilatation of the interface.

For the case of the type of martensite in steel with a $\{225\}$ habit plane, Bowles and Mackenzie⁵ seemed to succeed in correlating the experiments with the theory, assuming a dilatation on the interface of nearly 2%. However, recent measurements have indicated that in several types of steel, martensite of the $\{225\}$ habit showed a dilatation parameter, δ , not significantly different from unity (no dilatation)⁷. Also it appeared that, if the theory was applied in such a way that the correct orientation relation was used, the predicted direction of the shape deformation was different from that experimentally found⁸.

Recently several generalized crystallographic theories of martensite transformation were proposed, which try to overcome these difficulties. However, up to the present, it seems that the situation is still controversial. Perhaps an important drawback of the current theories is that they are not concerned with the actual process of nucleation and growth of martensite. In the theories it is assumed that the habit plane is, at the same time, the plane of a plate-shaped crystal, the plane semi-coherent boundary which performs the transformation, and the plane interface of the martensite crystal. The formation of one martensite plate is conceived as a single process.

Experimental observations on the surface martensite and also on martensite of the $\{252\}$ type⁹, strongly suggest that there are at least two stages in the transformation process, each of which has a different transformation mechanism and a different "crystallography". It is therefore questionable whether the whole process of the transformation can be comprised by one of the existing mathematical theories. Surface martensite, which has a $\{112\}$ habit, can be conceived as a martensite belonging to the $\{225\}$ type. We believe that several features of surface martensite may provide useful indications applicable to the problems of plate martensite. Surface martensite can be observed during its growth, and from this observation it is, for instance, easy to see that no dilatation occurs, at least not in the direction of needle growth^{2,10}.

Although it cannot be expected that all the crystallographic features of surface martensite are the same as those of plate martensite, the fact that the former has a habit which must be described in terms of a crystallographic plane makes it desirable not to exclude some similarities of certain aspects of surface martensite with plate martensite. For instance, the way in which surface martensite grows and the formation of straight (plane) boundaries draws attention to the way in which a habit plane must be defined.

PRESENT SITUATION

Difficulties regarding the application of the theory of Bowles and Mackenzie on martensite of the (252) type in steel were pointed out eight years after its appearance by the authors¹¹ themselves. They showed that the direction and magnitude of the shape strain predicted with the theory were different from those observed experimentally.

In order to meet those difficulties, several proposals have been made. Bowles and Mackenzie suggested an anisotropic dilatation whilst Crocker and Bilby¹² proposed a complex lattice invariant deformation composed of shears on several systems. Morton and Wayman⁸ concluded that the I.P.S. theory cannot account for all aspects of the "(225) transformation". Either the habit plane and the orientation relation is predicted successfully but with a wrong direction of the shape deformation, or the correct habit plane and direction of the shape deformation are predicted but with an orientation rotation which differs from the observed one.

Liebermann and Bullough^{13,14} proposed a composite martensite theory. In this the lattice invariant deformation occurs partly by slip and partly by twinning.

The model can be written mathematically

$$E_c = R_{or} B R_u(\omega) S(\alpha) S(\beta)$$

where E_c is the total transformation distortion (shape deformation), $S\alpha$ and $S\beta$ are two shears in the common direction $[\bar{1}01]_A^*$, R_u is the rotation over an angle, ω , around an axis perpendicular to the twinning direction, B is the Bain deformation and R_{or} is the usual orientation rotation. Wayman^{15,16} has pointed out that in this formulation the correct martensite is not obtained, because the Bain deformation is applied to austenite rotated by R_u , resulting in a structure that is triclinic rather than tetragonal or cubic. Perhaps a still more important drawback is the difficulty to visualize how the development of untwinned martensite could influence the habit plane, after a twinned midrib region has already formed. (Indeed there are important indications that the midrib is the first stage of the transformation¹⁷. Ross and Crocker¹⁸ and, independently, Acton and Bevis¹⁹, developed a generalized theory of martensite crystallography which is based on a double shear. The basic equation of this theory is

$$F = RPS_2S_1$$

where F is the shape deformation, R and P are the orientation rotation and the Bain strain, respectively, and S_1 and S_2 are two generally independent shears.

* Austenite and martensite planes and directions will be indicated with the indices A and M respectively. Directions and planes without additional indication are taken to belong to austenite.

A drawback of this theory is that if S_1 and S_2 are chosen in such a way that the (252) martensite variant is predicted, the predicted magnitude of the shape strain and orientation relation differ significantly from those found experimentally^{16,18,19}. It is also a problem that a phase boundary containing two different slip systems will change its structure during its progress from position (a) to position (b) as shown in Fig. 3. At the edge of the boundary the dislocations of the two systems separate and in the middle of the boundary they change their relative positions during the movement of the boundary. In particular, if the distribution of the dislocations is not homogeneous, a large friction stress will result. As remarked by Dunne and Wayman²⁰, in general, the two interfaces would not be parallel. However, the other possibility is that the region between the two dislocation arrays has not yet the correct b.c.c. structure. For reasons of low energy, the two dislocation walls must be very close together. This will result in a large friction stress and this makes the model unattractive.

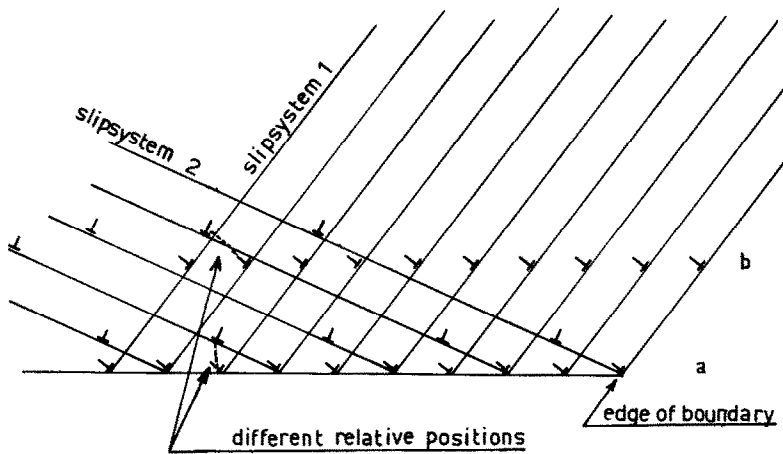

Fig. 3. Semi coherent interface with two sets of dislocations on different slip planes, after transformation over some distance (from a to b) the boundary changes its character.

Bowles and Dunne²¹ have proposed a plastic accommodation model of the (252)_A transformation. This approach is also discussed by Dunne and Wayman²⁰. The basic equation of the model can be written:

$$S = LP = RBC^{-1}P$$

where C^{-1} represents the lattice invariant shear, B is the Bain deformation, R the orientation rotation and S is the shape deformation. P is a plastic accommodation strain in the austenite, preceding the transformation.

The assumptions on which the model is based are,

- (1) a macroscopic undistorted habit plane of the form (hkh) ;
- (2) a lattice invariant shear C^{-1} in the $[\bar{1}01]_A$ direction;
- (3) that the close-packed directions $[\bar{1}01]_A$ and $[\bar{1}\bar{1}1]_M$ remain parallel.

The necessary contraction of $1\frac{1}{2}$ –2% in the $[\bar{1}01]_A$ direction, due to the reduction in atomic spacing, must be compensated for because this direction lies in the (hkh) habit plane. This compensation cannot be performed by C^{-1} because $[\bar{1}01]_A$ lies in the slip plane of this lattice invariant deformation. Therefore, it is proposed that

compensation will occur by a uni-axial strain in the $[\bar{1}01]_A$ direction in the austenite, preceding the transformation. This strain is an invariant line strain which can be resolved in shears on $(\bar{1}\bar{1}1)_A$ and $(1\bar{1}1)_A$ in $[011]_A$ and on $(\bar{1}11)_A$ and $(1\bar{1}1)_A$ in $[110]_A$.

The model of Bowles and Dunne is closely related to the matching model of Frank²². In both the former and the latter model close-packed directions are parallel and lie in the interface. In fact, in the case where the lattice invariant shear is restricted on the (101) plane, the model of Bowles and Dunne is essentially the same as that of Frank.

Of the generalized theories and models discussed in this section, the model of Bowles and Dunne seems to be the most attractive. Indeed good agreement with experimental results was obtained for Fe-C, Fe-Mn-C and Fe-Cr-Mn-C steels^{16,21,23}. However, the model does not account for the experimentally observed non-parallelism of the close-packed directions. As a solution to this difficulty Bowles and Dunne²¹ suggested that the model can be extended to account for habit planes off the $[\bar{1}01]_A$ zone. However, Dunne and Wayman¹⁶ have pointed out that in this case, a very complicated accommodation strain is required, which cannot in a reasonable way be resolved into physically realizable shears. We feel, however, that even in the more simple case of assumed parallelism of close-packed directions, the slip systems that must be assumed to predict the crystallography of the transformation are rather complicated. The model is, in fact, a tool which can be used to estimate which lattice invariant shears have possibly occurred. However, a real quantitative theory based on the complete mechanism of formation of a complete martensite crystal is, at the moment, perhaps, impossible, due to the lack of knowledge of thermodynamic functions of intermediate stages, of states of stress, etc.

SURFACE MARTENSITE

Surface martensite can be found in several quite different alloys, for instance, in high carbon steel²⁴, stainless steel²⁵, and iron-nickel^{26,27} alloys. Habit plane and orientation determinations were first made by Klostermann and Burgers²⁷, and Klostermann^{2,10}. It was found that the needle-shaped martensite exhibited a habit of the plane-type because the needles appeared to lie in $\{112\}$ austenite planes. From this result it can be deduced that surface martensite is not essentially different from plate martensite. The most important difference could be that in the case of surface martensite accommodation deformations are more easily performed. Therefore a generalized theory of martensite transformation should include the occurrences in the case of surface martensite, or at least certain features of it.

Several results of our study of surface martensite have been published elsewhere^{2,10,27,28} and some of the important items will be mentioned below, together with new results. Figure 4 shows surface martensite needles on a single crystal with a $(\bar{1}21)$ austenite orientation. The needles exhibit slow growth and from the large differences in the growth velocity (10^{-6} – 10^{-1} m/s) which depends largely on the orientation of a needle and on prior austenite deformation, it is concluded that thermally-activated dislocation movement will perhaps be more important than Snoek interaction²⁹ in determining the velocity of growth. The orientation of the austenite single crystal of Fig. 4 is indicated in Fig. 5, together with several directions of growth of the needles and the way in which branching occurs.

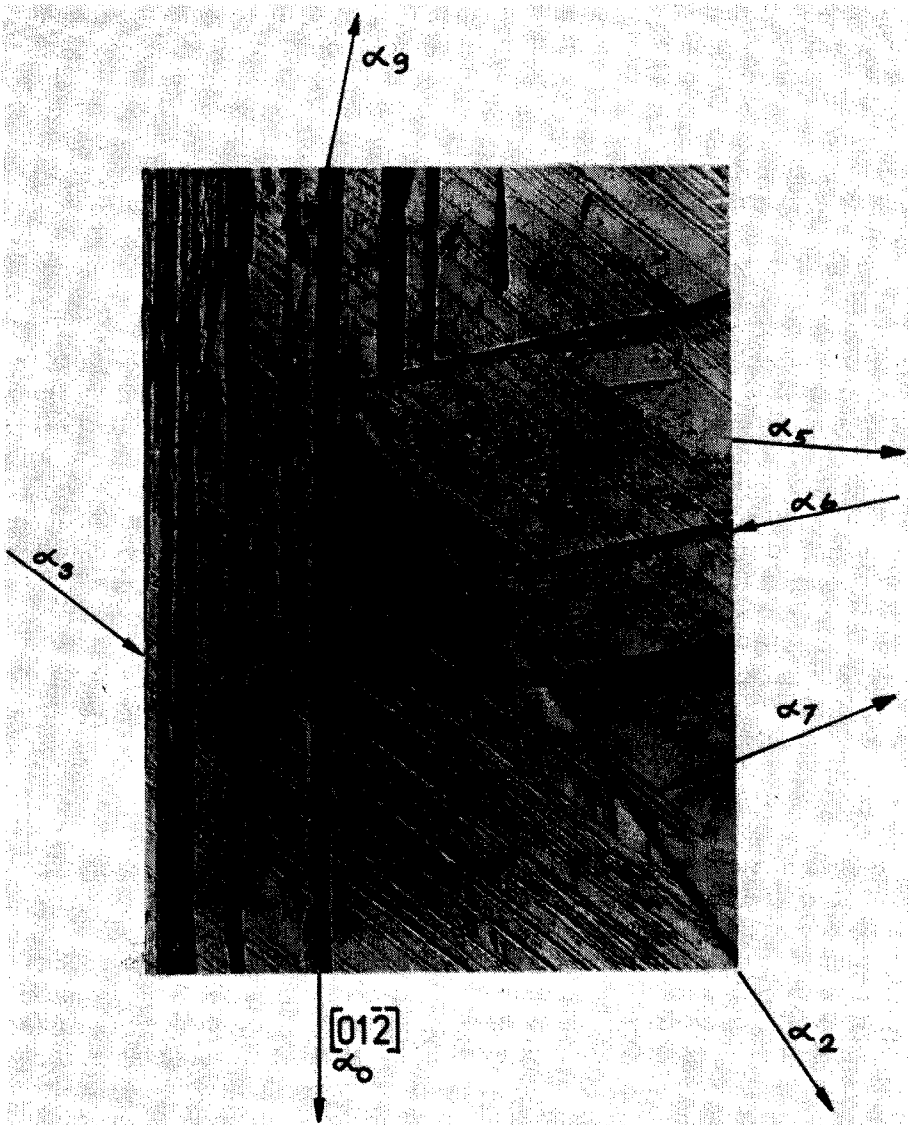

Fig. 4. Directions of growth of surface martensite needles on a single crystal with a $(\bar{1}21)_A$ orientation. ($\times 100$)

The normals of the surface martensite needles always appear to be close to $\{112\}$ austenite poles, not only for the case of Fig. 5 but also for specimens of other orientations^{2,27}. The boundaries of a surface martensite needle were classified as type I, II and III as indicated in Fig. 6.

Normals to type III boundaries were often close to $\{112\}$ poles. It was suggested^{2,10} that boundaries, for which corresponding sets of crystal planes in austenite and martensite have a structure that is similar and at the same time nearly parallel, will be energetically favourable. In this way boundary habits of the type described in Fig. 1(b) can be formed. The distance of close-packed rows of atoms in the corre-

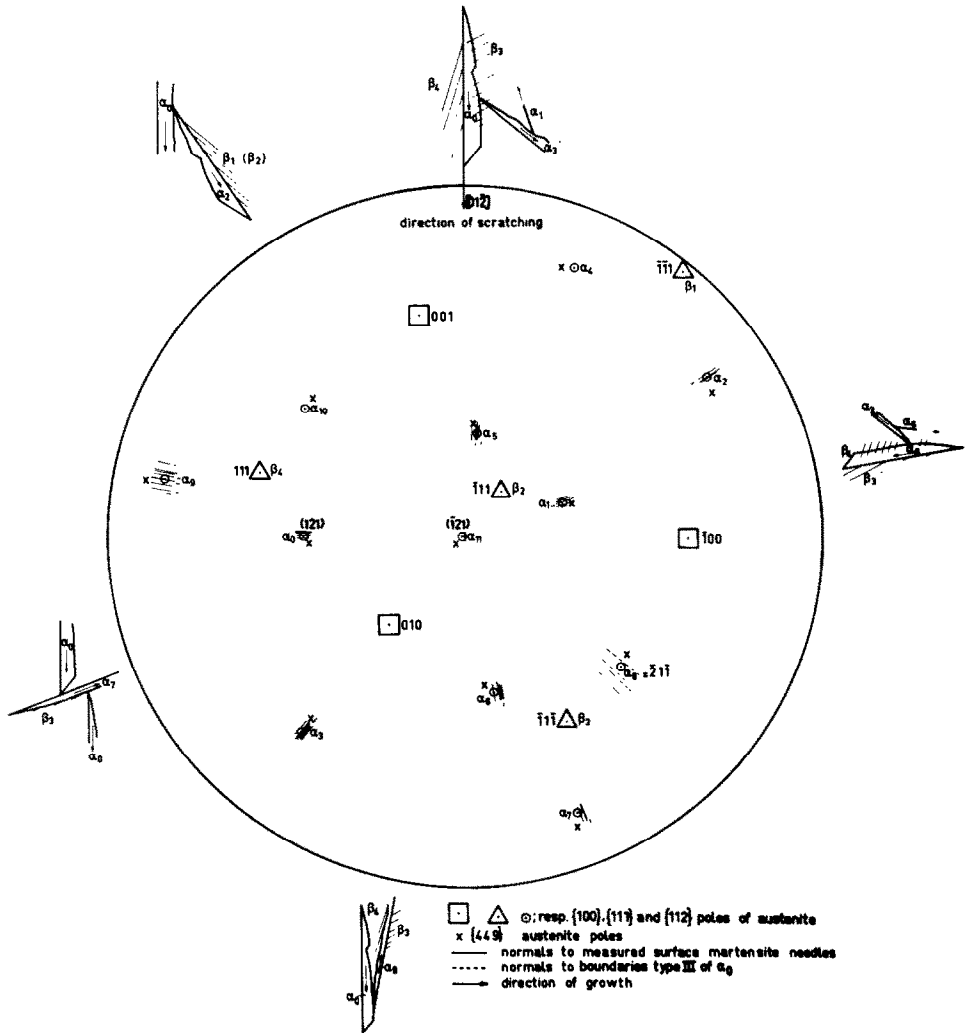

Fig. 5. Stereographic projection of the austenite orientation of the specimen of Fig. 4 ($\bar{1}21$)_A. Also indicated are the way in which branches are formed, slip lines (β) due to accommodation in the austenite, and normals to the surface martensite needles.

TABLE I

Planes containing the $[\bar{1}01]$ direction in austenite	Separation of close-packed $[\bar{1}01]$ rows in austenite (A)	Planes containing the $[\bar{1}\bar{1}1]$ direction in martensite	Separation of close-packed $[\bar{1}\bar{1}1]$ rows in martensite (A)
101	3.58	112	4.04
111	2.19	011	2.33
121	6.20	$\bar{1}32$	6.16
212	8.39	134	8.38

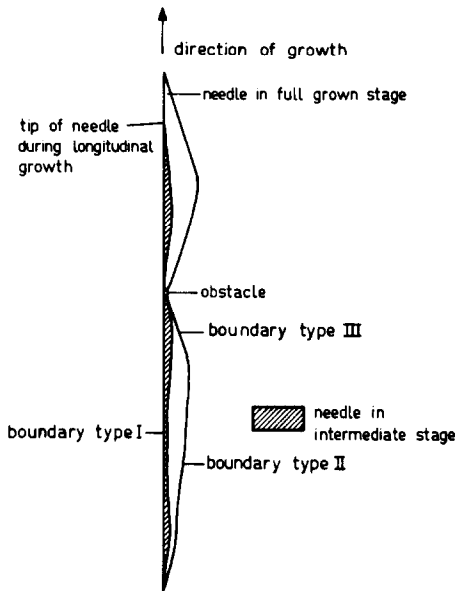

Fig. 6. Intermediate and final morphology of surface martensite needle with boundaries Type I, II, and III.

sponding planes in both lattices is regarded as a criterion for similarity. In Table I distances of closely-packed rows for lattice planes in austenite and martensite are indicated.

It can be seen that the distance for the corresponding planes $(121)_A$ and $(\bar{1}32)_M$ is nearly the same, 6.20 and 6.16 Å, respectively. Therefore this is the lowest index plane for which this similarity can be found. (A better similarity even is found for the set $(212)_A$ and $(134)_M$ with distances of close-packed rows of 8.39 and 8.38 Å, respectively.)

Very accurate orientation determinations were made for the martensite on the specimen of Fig. 4. The orientation relation for the main variant (variant I) is indicated in Fig. 7 (contour lines) and the orientations of the weak variants are indicated in Fig. 8. These orientations are brought into standard orientation in Fig. 9, together with the theoretical orientation (indicated by t) expected from the I.P.S. theory for dilatation parameter $\delta = 1$ and for a lattice invariant deformation on $(101)_A$ $[\bar{1}01]_A$. It is indeed fascinating that the experimental orientation relations of surface martensite are so near to the one predicted theoretically by the I.P.S. theory for plate martensite of Fe-Ni of the same composition. The same result was found for surface martensite on specimens of a $(100)_A$ and a $(111)_A$ orientation².

The orientations of Fig. 8 are indicated quantitatively in Table II. From the orientation determinations it appeared that surface martensite is not twinned.

Figure 7 demonstrates that the I.P.S. theory cannot be applied to the habit plane and the orientation relationship, which are found experimentally for surface martensite. Orientations which satisfy the theory for a habit plane (121) are indicated with a dotted and dashed line. (For one of these orientations the graphical construction developed by Liebermann³⁰ is included.) The dotted and dashed line lies far from the maximum of the measured martensite orientations, indicated with contour lines.

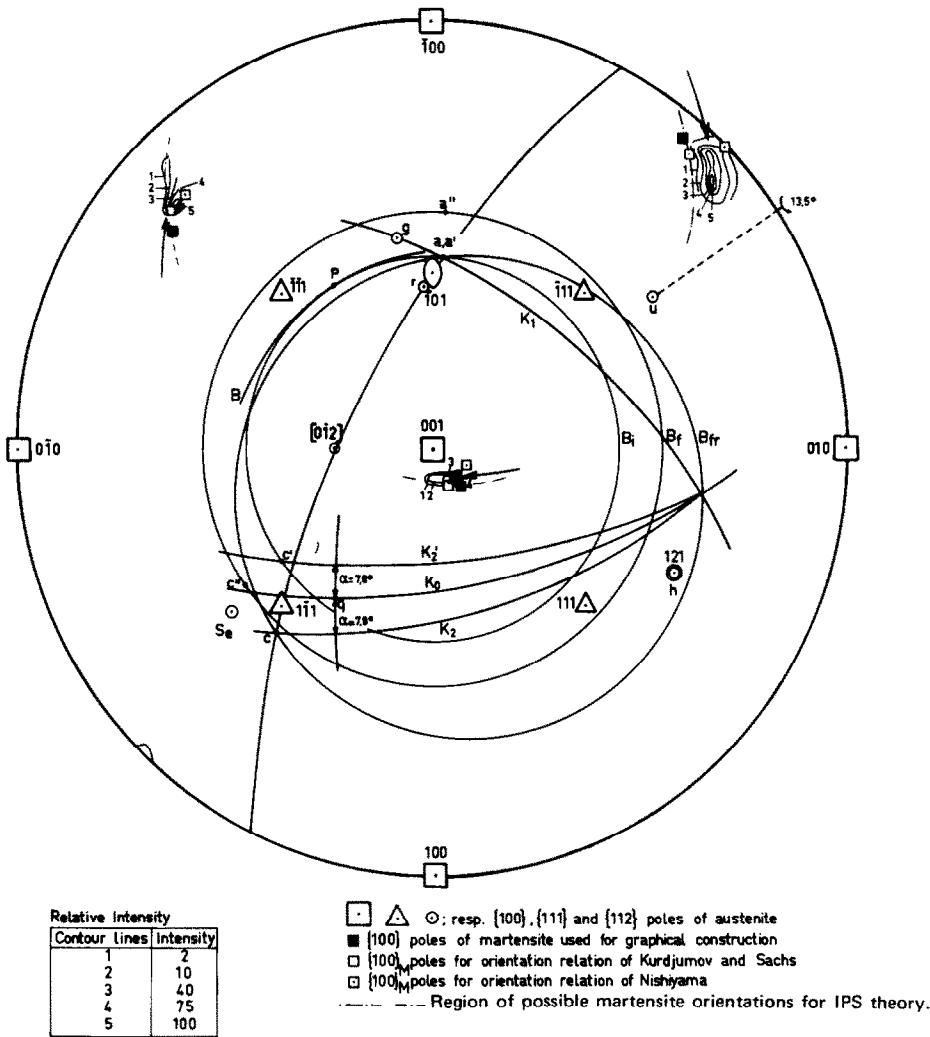

Fig. 7. Orientation relation of the main variant of Fig. 4 (α_0 with direction $[01\bar{2}]$) indicated with contour lines. Graphical construction according to the "best fit method" of Lieberman results in a range of orientations (dotted and dashed line) not consistent with the measured martensite orientations.

The shape deformation of surface martensite is nearly zero for a needle as a whole. The deformation is inhomogeneous and varies from place to place, even along the length of a needle. (This can be seen in Fig. 10.) It is therefore rather difficult to determine the shape deformation of surface martensite. In order to have at least some indication of it, however, the maximum horizontal and vertical inclination of a scratch was determined in a region of boundary type-I. The shape deformation in the initial stage is supposed to be an invariant plane strain on the habit plane (121). The direction S of the shape deformation was determined in the way indicated in Fig. 11. In this figure, h is the normal to the habit plane, l is a unit vector in the direction of a scratch, l' is the unit vector in the direction of this scratch after inclination by the shape

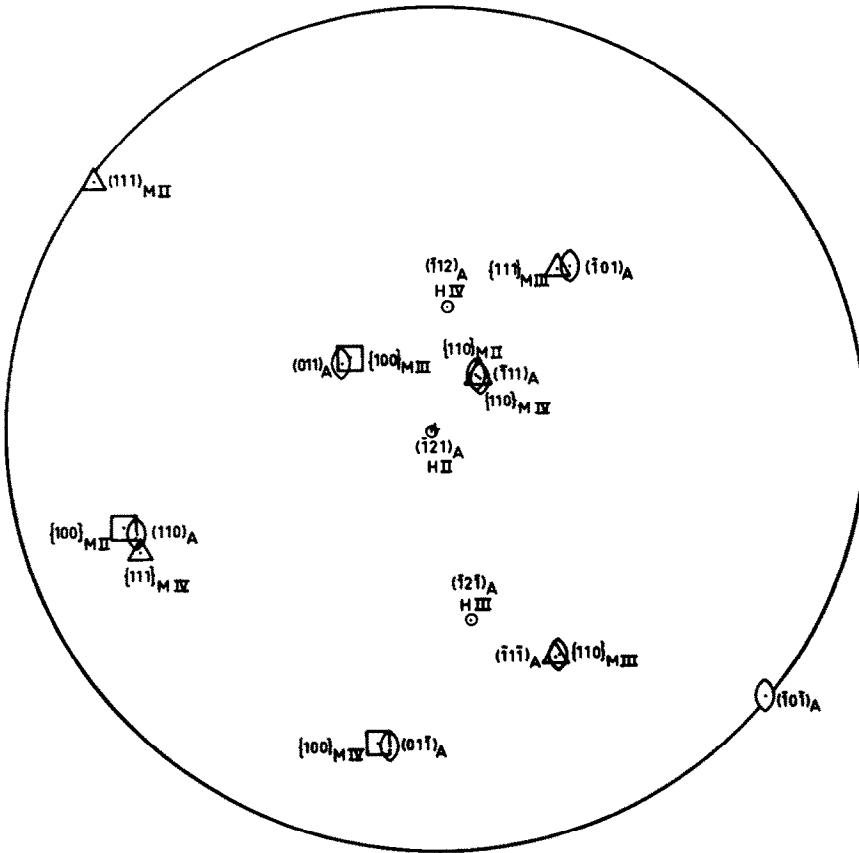

Fig. 8. Orientation relations of the weak variants of the specimen of Fig. 4.

TABLE II

Unit vectors in the directions $\{100\}_M$ expressed in relation with the austenite axes.

	$[100]_M$	$[010]_M$	$[001]_M$
Variant I	0.7132	0.6833	0.1374
	-0.6996	0.7096	0.0924
	-0.0419	-0.1668	0.9863
Variant II	0.7169	0.6858	0.1270
	-0.6959	0.7083	0.0975
	-0.0227	-0.1633	0.9877
Variant III	0.7169	0.6869	0.1495
	-0.6946	0.7058	0.0976
	-0.0453	-0.1616	0.9842
Variant IV	0.7181	0.6858	0.1236
	-0.6934	0.7144	0.0371
	-0.0366	-0.1495	0.9885

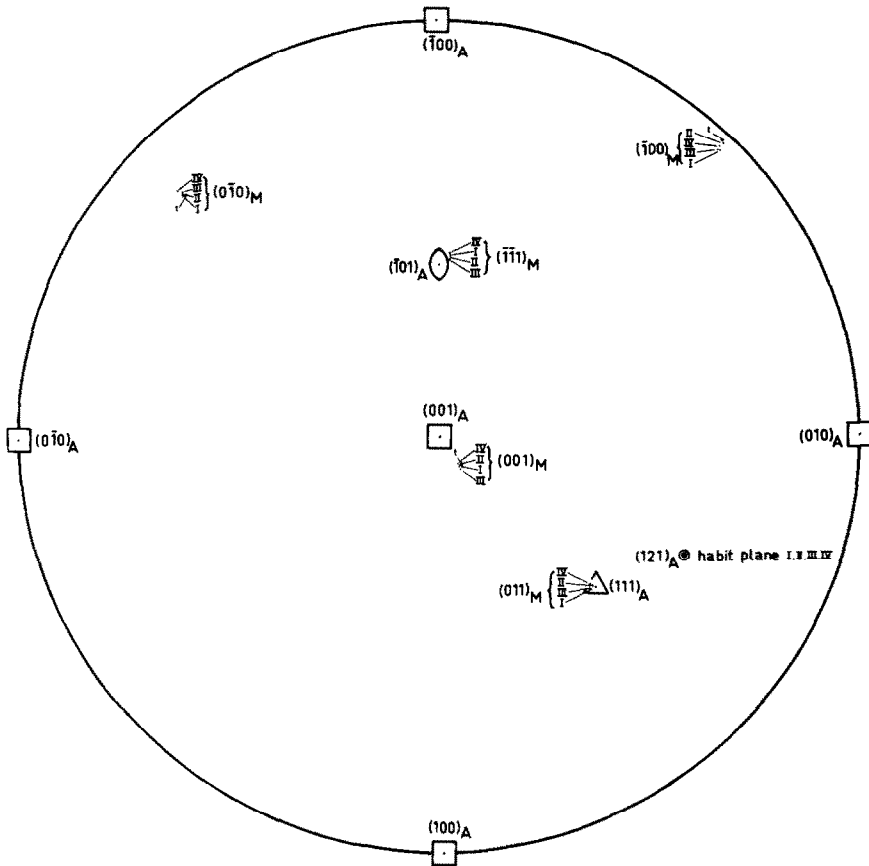

Fig. 9. Orientation relations of the martensite needles of the specimen of Fig. 4. The martensite orientation predicted by the I.P.S. theory for $\delta = 1$ is indicated with l .

deformation, and λ is a factor indicating the expansion normal to the habit plane caused by the difference in specific volume of martensite and austenite. For the alloy Fe-30% Ni, $\lambda = 1.026$.

From Fig. 11 it follows:

$$s = \frac{\lambda l'}{(h \cdot l')} - \frac{l}{(h \cdot l)}$$

For a needle on a (100) plane it was found that:

$$l = \begin{bmatrix} 0 \\ -0.6101 \\ -0.7944 \end{bmatrix} \quad l' = \begin{bmatrix} 0.0654 \\ -0.6873 \\ -0.7229 \end{bmatrix}$$

with

$$h = \frac{1}{\sqrt{6}} (\bar{1} \bar{2} \bar{1}), \text{ } s \text{ is calculated as}$$

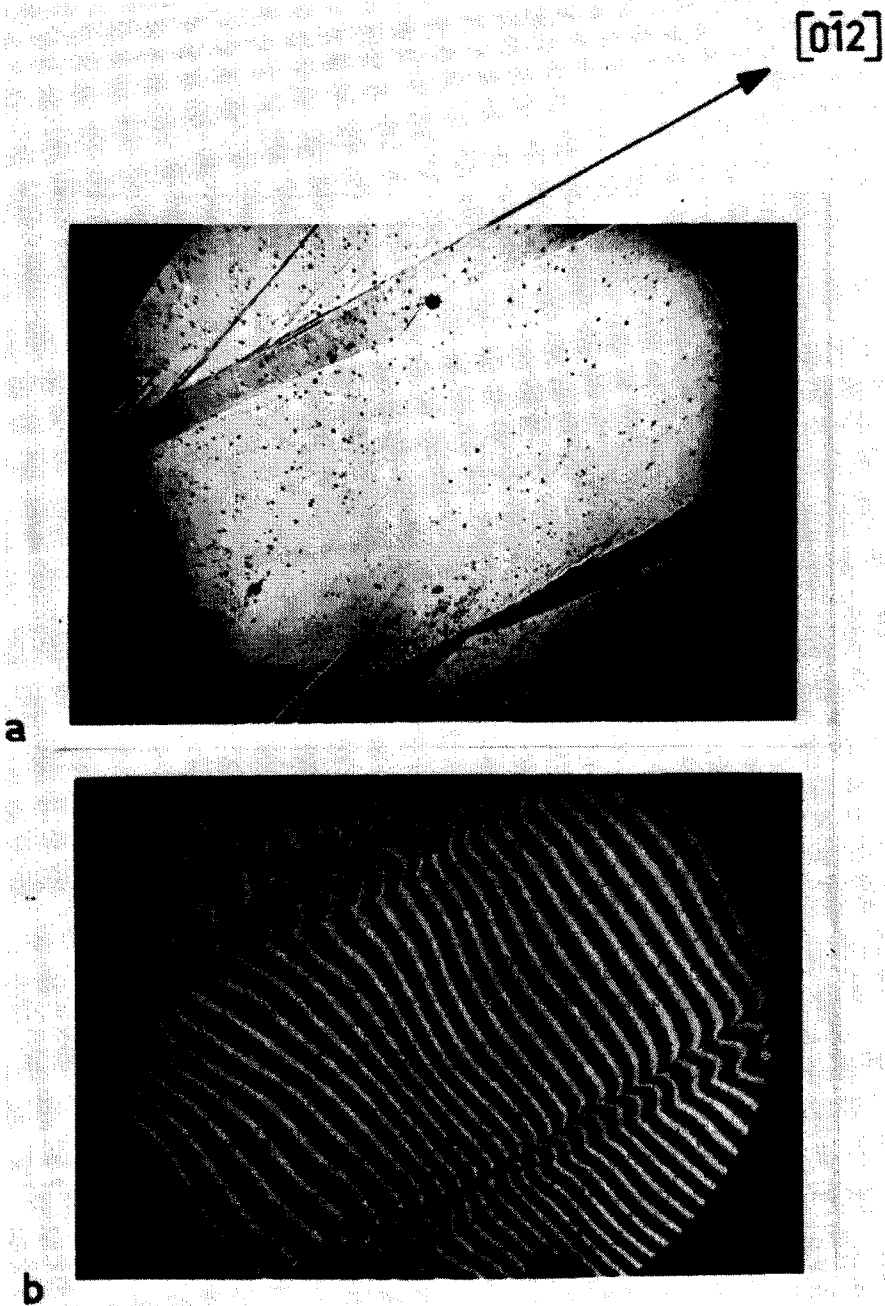

Fig. 10. (a) Surface martensite on a specimen with a (100) orientation. ($\times 340$) (b) Interference micrograph of the same region of (a) demonstrates the inhomogeneous shape deformation of surface martensite. The distance between the bands corresponds to a difference in height of $0.27 \mu\text{m}$ ($=0.5 \lambda$).

$$s = \begin{bmatrix} 0.0864 \\ -0.1103 \\ 0.0696 \end{bmatrix}.$$

This direction is rather near the $[3\bar{5}3]$ direction calculated by Bowles and Dunne²¹ for the direction of the shape deformation, and for $\sigma=0$. The shear angle between h and $h+s$ is

$$\gamma = 8^\circ 32'.$$

The unit vector in the direction of s is indicated in Fig. 7 with Se .

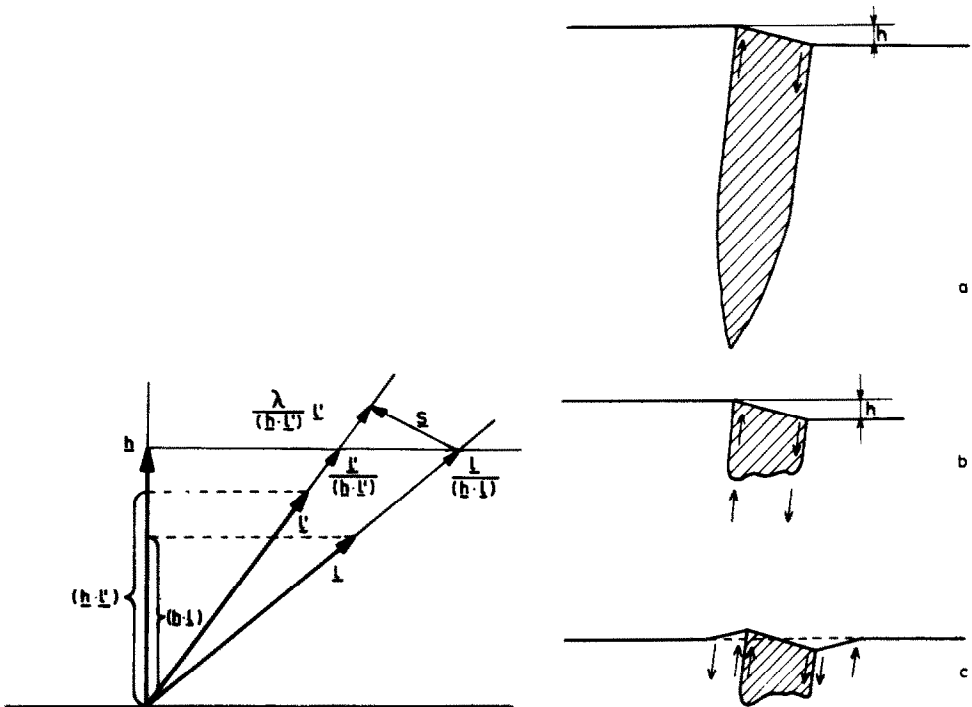

Fig. 11. Determination of the shape deformation from the inclination of a scratch with parallel unit vector direction l which is deviated to l' .

Fig. 12. (a) Translation of the specimen surface over the distance, h , due to the shape deformation of a martensite plate. (b) Translation of the specimen surface by a surface martensite needle as demonstrated in the figure is not expected because relatively large accommodation deformations are necessary. (c) Expected accommodation pattern of a surface martensite needle (schematic).

ACCOMMODATION DEFORMATION

The deformation in the austenite necessary to accommodate a surface martensite needle will not be analogous to that which is found for plate martensite (Fig. 12 (a) and (b)), but a type of accommodation indicated in Fig. 12 (c) can be expected. In this case the deformation in the austenite on the sides of the martensite needle is more or less the opposite of that in martensite. If lateral growth of martensite proceeds further,

the shape deformation may consequently be compensated beforehand. The relief which follows from the interference band of Fig. 10(b) confirms these ideas to some extent.

The accommodation deformations will cause spread in the martensite orientations. They rotate the austenite and if this transforms to martensite the martensite will inherit its rotated position. The rotation axis, r , of these accommodation rotations can be expected to be perpendicular to Se and to $[1\ 2\ 1]$, the normal of the habit plane (h in Fig. 7). Also shown, with arrows, in Fig. 7 is the expected accommodation rotation around the axis r (near $[\bar{1}\ 0\ 1]$).

The pattern of martensite orientations given by the contour lines of Fig. 7 suggests a rotation of the martensite orientations. In fact, if it is assumed that the initial orientation of the martensite is that of the maximum intensity, the observed rotation agrees very well with the predicted rotation. Because of its complicated character the shape deformation of surface martensite needs further (extensive) study.

Figure 13 shows a cross-section of a surface martensite needle which has grown on a (100) plane in a $[0\ \bar{1}\ 2]$ direction. The little midrib visible as a little narrow line in the top of the section is intriguing. This midrib corresponds with a narrow groove on the (100) surface. The little line is found in the section again and again, every time after a new layer of the intersection interface is polished away. However, its direction is not always the same but the angle φ (Fig. 13) can vary a few degrees about an average direction which corresponds to that expected if the midrib lies in the (121) plane. The variations of the direction of the section of the midrib probably indicate that after the first transformation process other processes come into action which finally rotate the

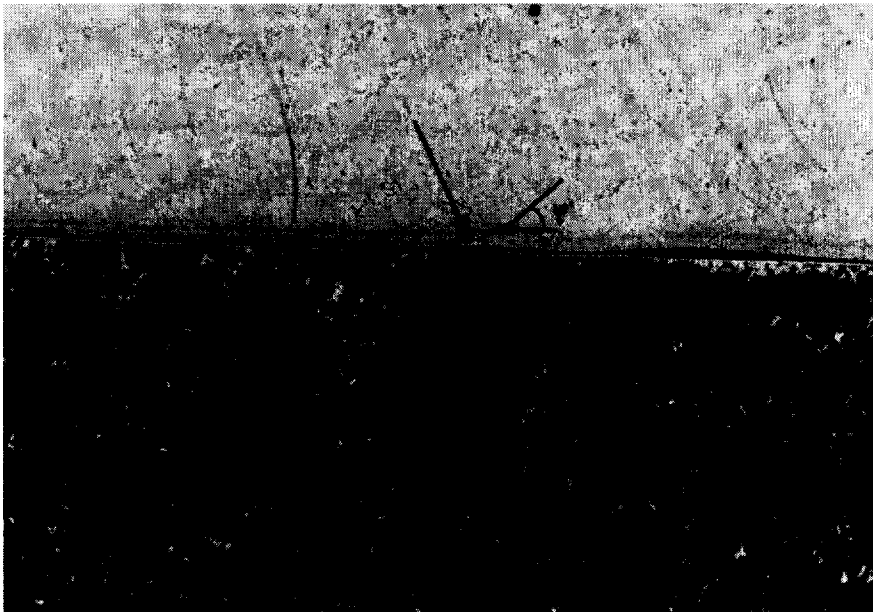

Fig. 13. Section of surface martensite needle grown on a (100) crystal surface. A small midrib can be seen at the surface indicated by an arrow. The specimen was coated with a layer of $0.5\ \mu\text{m}$ nickel and a layer of $50\ \mu\text{m}$ copper. ($\times 1600$)

midrib. This is an indication that the complete process probably cannot be described by the existent "mathematical theories" in an efficient way.

DISCUSSION

At first sight, very strange results have been obtained for the experimental values of surface martensite, that is: an orientation relationship predicted by the I.P.S. theory for plate martensite for the lattice invariant shear on $(101)_A$ $[\bar{1}01]_A$, a habit plane on $(121)_A$ and a direction of the shape deformation in the midrib region predicted by a Frank-type of matching. This lead us to the supposition that in the initial stage of the transformation process a Frank type of matching will indeed take place. Perhaps this may be explained by the lower surface energy of the phase boundary that is obtained in this way. Probably a fit in the boundary on a lattice parameter scale will lead to a rational habit plane in the case of surface martensite.

The necessary contraction in the $[\bar{1}01]_A$ direction is often seen as a difficulty²². However, as proposed by the present author², growth of martensite in iron alloys will be stimulated in a region of hydrostatic tension. Therefore, the contraction in the $[\bar{1}01]_A$ direction can possibly stimulate growth causing a region of hydrostatic tension in the phase boundary perpendicular to this direction. After the formation of a very narrow lath under conditions of a Frank-type of matching, growth in a transverse direction (thickening of the needle) may proceed with a different mechanism. A gradual tilt of the phase boundary may take place until an interface plane of the type $(3, 15, 10)$ or (143) is obtained which creates by its progress a perfectly invariant plane strain. This invariant plane strain must, however, be compensated by accommodation strains in the austenite preceding the transformation. During this process (illustrated in Fig. 14) the dislocations in the mobile interface remain the same and perform the same lattice invariant slip on the system $(101)_A$ $[\bar{1}01]_A$. A difficulty is that for a homogeneous deformation the (121) and (143) planes cannot both be

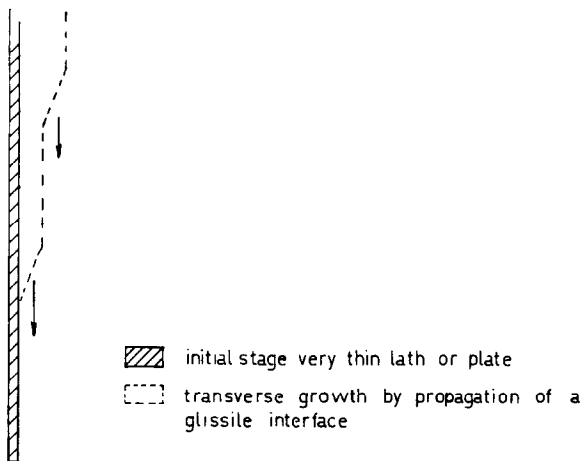

Fig. 14. Schematically indicated transverse growth by propagation of a glissile interface after formation of a very thin lath under conditions of matching of close packed directions.

invariant, unless every plane is invariant and the shape strain is described by the unit matrix (and a factor for isotropic dilatation). For the martensite needles as a whole the shape deformation is, indeed, very small. But in the midrib region of surface martensite the shape deformation is considerable and both the (143) and the (121) planes cannot be invariant.

Experimental observations indicate that the midrib of surface martensite has a slightly different orientation from place to place. Perhaps this can be attributed to accommodation rotations. Accommodation deformations can also be the cause of differences in shape deformation. At this point we draw attention to the results obtained by Shimizu *et al.*⁹. In an alloy of Fe-9.8 Cr-9.1 C they observed twins in martensite plates of the {225} type. Twins and other planar defects were bent, in particular in the midrib region.

The results obtained for surface martensite can perhaps also indicate the way in which a solution can be obtained for the problems that are still present for the (225) type of martensite in steel. Shimizu, Oka and Wayman³¹ have observed very thin platelets of martensite {252} planes in a Fe-8 Cr-1 C alloy. The thickness of the plates was difficult to establish but must have been less than 200 Å in several cases, as can be observed from the micrographs in their paper. In the case of the formation of a very thin martensite plate the surface energy will be the most important term in a free energy balance and a high surface energy is impossible. If, for instance the surface energy is 800 erg/cm² for a plate with a thickness of 200 Å, more than half the total free energy difference (estimated at 250 cal/mol) is consumed for the surface energy of the plate. It was not possible to form plates of a thickness of 100 Å. The system will choose, perhaps in its initial stage, a surface energy as low as possible.

Now, if we compare the surface energy of a (252)- (or even a (121)-) boundary with a (3, 15, 10) boundary, a better fit on a scale of the lattice parameter can be obtained for the first case. Further, the screw dislocations in the boundary of the (252) type will have a lower energy than the dislocations of mixed orientation in the (3, 10, 15) boundary. Perhaps also, for the (252) types of plate martensite, the first stage is a very thin plate which develops under matching conditions as described by Frank and for which a minimum surface energy is obtained. During transverse growth, a gradual transition from a phase boundary with a Frank-type of matching to a glissile invariant plane with dislocations performing slip on the system (101) $[\bar{1}01]$ may cause an orientation relation with a deviation towards the poles expected for an orientation relation belonging to the (3, 15, 10) habit plane. An analysis of the shears that may occur can be performed best in the way described by Bowles and Dunne²¹, and clarified further by Dunne and Wayman¹⁶. The point of view, however, in these papers, in which the transformation is seen as one single process, is possibly not adequate in many cases. According to the phenomenological theories it is proposed to predict the crystallography of the transformation from estimated systems of the lattice invariant deformation, but the lattice invariant deformations will be, in the case of the (252) transformation, very complicated, and will even vary from case to case. This means that we will possibly never have a satisfying generalized theory of martensite transformation, in the sense mentioned above. In fact, the nice consistency of I.P.S. theory and the experimental values for several cases (*cf.* Efsic and Wayman⁶) may be regarded as coincidental. The theories appear not to predict the crystallography, but make it possible to estimate the lattice invariant deformation from the experimentally determined habit plane (in the inter-

pretation of plane of the plate which is at the same time an invariant plane), orientation relation, and shape deformation.

CONCLUSIONS

(1) Three different interpretations of the concept habit plane are used: (a) the plane of the plate of a plate-shaped crystal, (b) the plane boundary of a plate-shaped product, (c) a semi coherent glissile interface. It is necessary to distinguish between these concepts.

(2) Accurate measurements of the orientation relationship of surface martensite have given results which lie very close together around the martensite orientation and which are predicted by the I.P.S. theory for a lattice invariant shear on $(1\ 0\ 1)_A [\bar{1}\ 0\ 1]_A$. However, its habit plane is on (121) (needles on the specimen surface lie in $\{121\}$ planes) and not on the $(3, 15, 10)$ plane predicted by the theory.

(3) The shape deformation of surface martensite in the midrib region is in the direction predicted by a matching condition proposed by Frank. The shape deformation is not homogeneous, and it is small for the complete needles.

(4) On a section of a surface martensite needle a small midrib was observed, which corresponded with a narrow groove on the surface.

(5) It is proposed that surface martensite grows in its first stage as a very narrow lath in such a way that the surface energy is at a minimum. At this stage a Frank-type of matching will be obtained. The contraction in the $[\bar{1}\ 0\ 1]_A$ close-packed direction can possibly promote the transformation in directions parallel to the (121) matching plane. During transverse growth, a glissile interface boundary parallel to $(3, 15, 10)$ may develop. The shape deformation of the transformation must be compensated to a large extent in this stage of the transformation by accommodation deformations in the austenite.

(6) The observations made on surface martensite (in particular the direction of the shape deformation and the occurrence of boundaries of type II and III) are in favour of the Bowles and Dunne model, in which a Frank type of matching is also proposed with an accommodation deformation in the austenite. However, if the two stages in the transformation process proposed for surface martensite are also accepted for plate martensite, the non-parallelism of the $[\bar{1}\ 0\ 1]_A$ and $[\bar{1}\ \bar{1}\ 0]_M$ close-packed directions becomes plausible as due to a gradual deviation from the initial process.

(7) A generalized theory of martensite transformation, which tries to predict the whole transformation process assuming a set of lattice invariant shears, will perhaps never be very successful because the transformation can proceed in different stages, involving rather complex shears.

ACKNOWLEDGEMENTS

The author is much indebted to Professor Dr. W. G. Burgers for his constant interest in this work, and for many ideas and enlightening discussions. Thanks are also due to Mr. W. H. J. Bruis for metallographic work and to Mr. C. G. Roordink and Mr. L. A. J. van Velsen for preparing the drawings, and to Mr. F. Willemse for reading the manuscript.

A part of this work was sponsored by the Metals Research Group F.O.M.-T.N.O.

REFERENCES

- 1 J. F. Breedis and C. M. Wayman, *Trans. AIME*, 224 (1962) 1128.
 - 2 J. A. Klostermann, *Thesis*, Univ. Delft, 1970.
 - 3 L. C. Chang and T. A. Read, *Trans. AIME*, 191 (1951) 47.
 - 4 M. S. Wechsler, D. S. Liebermann and T. A. Read, *Trans. AIME*, 197 (1953) 1503.
 - 5 J. S. Bowles and J. K. Mackenzie, *Acta Met.*, 2 (1954) 129, 138, 254.
 - 6 E. J. Efsic and C. M. Wayman, *Trans. AIME*, 239 (1967) 873.
 - 7 D. P. Dunne and J. S. Bowles, *Acta Met.*, 17 (1969) 201.
 - 8 A. J. Morton and C. M. Wayman, *Acta Met.*, 14 (1966) 1567.
 - 9 K. Shimizu, M. Oka and C. M. Wayman, *Acta Met.*, 19 (1971) 1.
 - 10 J. A. Klostermann, The mechanism of phase transformations in crystalline solids, *Monograph and Rept. Ser. No. 33*, Inst. Metals, 1969, p. 143.
 - 11 J. S. Bowles and J. K. Mackenzie, *Acta Met.*, 10 (1962) 625.
 - 12 A. G. Crocker and B. A. Billy, *Acta Met.*, 9 (1961) 678, 992.
 - 13 D. S. Liebermann and R. Bullough, *Phys. Status Solidi*, 12 (1965) 657.
 - 14 D. S. Liebermann, *Acta Met.*, 14 (1966) 1723.
 - 15 C. M. Wayman, *Advan. Mater. Res.*, 3 (1968) 147.
 - 16 D. P. Dunne and C. M. Wayman, to be published in *Met. Trans.*
 - 17 H. J. Neuhäuser and W. Pitsch, *M.P.I. Rept. No. 52/1*, 1970.
 - 18 N. D. H. Ross and A. G. Crocker, *Acta Met.*, 18 (1970) 405.
 - 19 A. F. Acton and M. Bevis, *Mater. Sci. Eng.*, 5 (1969-70) 19.
 - 20 D. P. Dunne and C. M. Wayman, *Acta Met.*, 19 (1971) 425.
 - 21 J. S. Bowles and D. P. Dunne, *Acta Met.*, 17 (1969) 677.
 - 22 F. C. Frank, *Acta Met.*, 1 (1953) 15.
 - 23 S. Jana and C. M. Wayman, *Met. Trans.*, 1 (1970) 15, 28.
 - 24 E. Hanke and O. Henkel, *Wissenschaftliche Berichte Folge I, Metallurgie und Giessereiwesen*, Heft 24, Verlag Technik, Berlin, 1953.
 - 25 R. Margerand, *Met. Corr. Ind.*, 37 (1962) 85, 154, 204.
 - 26 T. Honma, *J. Japan. Inst. Metals*, 21 (1957) 122, 126, 263.
 - 27 J. A. Klostermann and W. G. Burgers, *Acta Met.*, 12 (1964) 355.
 - 28 J. A. Klostermann, Physical properties of martensite and bainite, *Iron Steel Inst. Spec. Rept. 93*, 1965, p. 43.
 - 29 W. S. Owen, F. J. Schoen and G. R. Shrinivasan, *Phase Transformations*, Am. Soc. Metals, 1970, p. 157.
 - 30 D. S. Liebermann, *Acta Met.*, 6 (1958) 680.
 - 31 K. Shimizu, M. Oka and C. M. Wayman, *Acta Met.*, 18 (1970) 1005.
- J. Less-Common Metals*, 28 (1972)