

Mechanics of plasticity for finite strains : an engineering approach

Citation for published version (APA):

Veenstra, P. C., & Mot, E. (1967). *Mechanics of plasticity for finite strains : an engineering approach*. (TH Eindhoven. Afd. Werktuigbouwkunde, Laboratorium voor mechanische technologie en werkplaatstechniek : WT rapporten; Vol. WT0173). Technische Hogeschool Eindhoven.

Document status and date:

Published: 01/01/1967

Document Version:

Publisher's PDF, also known as Version of Record (includes final page, issue and volume numbers)

Please check the document version of this publication:

- A submitted manuscript is the version of the article upon submission and before peer-review. There can be important differences between the submitted version and the official published version of record. People interested in the research are advised to contact the author for the final version of the publication, or visit the DOI to the publisher's website.
- The final author version and the galley proof are versions of the publication after peer review.
- The final published version features the final layout of the paper including the volume, issue and page numbers.

[Link to publication](#)

General rights

Copyright and moral rights for the publications made accessible in the public portal are retained by the authors and/or other copyright owners and it is a condition of accessing publications that users recognise and abide by the legal requirements associated with these rights.

- Users may download and print one copy of any publication from the public portal for the purpose of private study or research.
- You may not further distribute the material or use it for any profit-making activity or commercial gain
- You may freely distribute the URL identifying the publication in the public portal.

If the publication is distributed under the terms of Article 25fa of the Dutch Copyright Act, indicated by the "Taverne" license above, please follow below link for the End User Agreement:

www.tue.nl/taverne

Take down policy

If you believe that this document breaches copyright please contact us at:

openaccess@tue.nl

providing details and we will investigate your claim.



technische hogeschool eindhoven

laboratorium voor mechanische technologie en werkplaatstechniek

rapport van de sectie: **Werkplaatstechniek**

titel:

**Mechanics of Plasticity for finite strains;
An Engineering Approach**

auteur(s): **Prof.dr. P.C. Veenstra
Ir. E. Mot**

sectieleider:-

hoogleraar: **Prof.dr. P.C. Veenstra**

samenvatting

In this article a model for finite plastic straining of a strainhardening material is presented. Instead of the constitutive equations for finite shears the following hypothesis is used: The principal directions of stress and strain are coincident in technical processes. This hypothesis is a technical approximation of the exact theorem stating that the principal directions of stress coincide with those of strainrate. This procedure proves to yield reasonable results which are both simpler to attain and physically much clearer and more obvious than the introduction of finite shear components of a strain tensor.

progress

blz.0 van 13blz.

rapport nr.0173

codering: P1,
P 6a

trefwoord:
plasticiteits-
mechanica

datum:
7 april 1967

aantal blz,
13

geschikt voor
publicatie in:
**International
Journal of
Mechanical
Sciences**

MECHANICS OF PLASTICITY FOR FINITE STRAINS;

An Engineering Approach.

P.C. Veenstra *

E. Mot. **

Summary.

In this article a model for finite plastic straining of a strainhardening material is presented. Instead of the constitutive equations for finite shears the following hypothesis is used: The principal directions of stress and strain are coincident in technical processes.

This hypothesis is a technical approximation of the exact theorem stating that the principal directions of stress coincide with those of strainrate.

This procedure proves to yield reasonable results which are both simpler to attain and physically much clearer and more obvious than the introduction of finite shear components of a strain tensor.

* Professor of Production Engineering, Technological University Eindhoven, Netherlands.

** Research Officer, Department of Production Engineering, Technological University Eindhoven, Netherlands.

List of symbols.

a, b	initial length in direction X, Y
a_1, b_1	deformed length in direction X, Y
c	material constant (stress if $\bar{\sigma} = 1$)
l	deformed length of an element of line
l_0	initial length of an element of line
m	strain hardening exponent
p, q, u, v, w	deformation quantities
r	deformed length of an arbitrary line
r'	partially deformed length of an arbitrary line
r_0	initial length of an arbitrary line
x, y, z	coordinate directions (indices)
$1, 2, 3$	principal directions (indices)
I, II	stages of strain (indices)
gamma γ	angle determining the shear strain
delta δ	natural (= logarithmic) strains
$\bar{\delta}$	effective natural strain
delta Δ	linear strains
etha η	director of an initial arbitrary line
nu ν	director of a deformed arbitrary line
ksi ξ	director of a partially deformed arbitrary line
sigma σ	tensile stresses
$\bar{\sigma}$	effective stress
tau τ	shear stresses
τ_{ij}	stress tensor

It is generally recognised that finite straining problems entail complicated mathematical procedures, especially when finite shear is involved. Moreover, the physical meaning of finite shear tensor components is not clear.

For these reasons, the present authors would suggest a different approach, which has already proved its value in several cases, e.g. for a model of metal cutting [1]

Though mathematically not quite correct, this approach seems to describe reality pretty well. It is known that in plasticity the principal directions of stress and strainrate are coincident. Now, in technical processes, a material is deformed efficiently, that is, the ultimate shape is attained from the initial one without unnecessary deformations. As a consequence of this technical fact, the straining will take place approximately in a constant direction during the entire course of the process. In that case, the principal directions of strain and strainrate will be coincident, hence, so will be the principal directions of stress and strain.

Under these assumptions, we can derive a relatively simple closed set of equations without the introduction of finite shear components.

In order to solve a problem, the following equations are available

(a) The equations of equilibrium, in Cartesian coordinates:

$$\tau_{ij,j} = 0 \quad (1)$$

(b) Transformation equations for principal directions of stresses, giving values of σ_1 , σ_2 and σ_3 and the angles between the principal directions and the coordinate system originally chosen.

(c) The yield condition according to Von Mises:

$$\bar{\sigma} = (\sigma_1^2 + \sigma_2^2 + \sigma_3^2 - \sigma_1\sigma_2 - \sigma_2\sigma_3 - \sigma_3\sigma_1)^{\frac{1}{2}} \quad (2)$$

(d) The Lévy-Von Mises' equations for principal directions:

$$d\delta_1 = \frac{d\bar{\sigma}}{\bar{\sigma}} \left(\sigma_1 - \frac{\sigma_2 + \sigma_3}{2} \right), \text{ cyclic} \quad (3)$$

in which

$$\delta_1 = \ln \frac{1}{l_1} \quad (4)$$

(e) The incremental effective strain

$$d\bar{\delta} = \left(\frac{2}{3}\{(d\delta_1)^2 + (d\delta_2)^2 + (d\delta_3)^2\}\right)^{\frac{1}{2}} \quad (5)$$

(f) A deformation equation, giving the amount of strainhardening

$$\bar{\sigma} = c\bar{\delta}^m \quad (6)$$

(g) Two equations stating that the principal directions of stress and strain are coincident (The third equation of this kind will be dependent).

Summarising, we have:

equations	new variables	number of new variables	number of equations
(a) equilibrium eq.	$\sigma_x \sigma_y \sigma_z$ $\tau_{xy} \tau_{yz} \tau_{zx}$	6	3
(b) transformation eq. for principal directions	$\sigma_1 \sigma_2 \sigma_3$	3	3
(c) yield condition	$\bar{\sigma}$	1	1
(d) Lévy-Von Mises' eq. for principal directions	$\delta_1 \delta_2 \delta_3$ $\bar{\delta}$	4	3
(e) incremental effective strain	-	-	1
(f) deformation eq.	-	-	1
(g) principal direction of strain = principal direction of stress =	-	-	2
	TOTAL	14	14

In order to obtain the principal directions of strain an arbitrary element of line is considered both in its initial and deformed states and its (natural) strain is calculated. Then differentiation with respect to its direction yields the directions of extreme elongation, which have been defined as principal directions.

Example.

For a general state of strain in which two shear components are zero, we have the following situation (Fig. 1):

(Fig. 1)

Fig. 1. Deformation of $A_0 B_0 C_0 D_0$ to $A_0 BCD$.

A finite, rectangular element $A_0 B_0 C_0 D_0$ is uniformly deformed to $A_0 BCD$. Tensile strain may occur in directions X, Y and Z, shear strain only in the XY-plane. Hence, Z is a principal direction. In Fig. 2 we have the same straining process, split up into two stadia:

$$(I) \quad A_0 B_0 C_0 D_0 \longrightarrow A_0 B' C' D'$$

$$(II) \quad A_0 B' C' D' \longrightarrow A_0 BCD$$

First we consider the straining of an arbitrary element of line $A_0 E_0$ to $A_0 E'$. In the next stage, $A_0 E'$ is strained to $A_0 E$. The directions of the line element considered are given by the angles η , ξ and ν , respectively. Its length is r_0 , r' and r respectively.

For the first stage we have

$$\delta_{r_I} = \ln r'/r_0 \quad (7)$$

and for the second stage

$$\delta_{r_{II}} = \ln r/r' \quad (8)$$

(I)

(Fig. 2)

(II)

Fig. 2. Strain of Fig. 1, split up into two stadia.

Hence, the total strain follows from

$$\delta_r = \ln r/r_0 = \delta_{r_I} + \delta_{r_{II}} \quad (9)$$

Apparently - even in this non linear case - we are allowed to superimpose logarithmic strains.

We also introduce linear strains:

$$\Delta_{a_I} = \frac{a_1 - a}{a} ; \quad \Delta_{b_I} = \frac{b_1 - b}{b} \quad (10)$$

From Fig. 2^I, we find that

$$\begin{aligned} r_0^2 &= x_0^2 + y_0^2 \\ r'^2 &= x_0^2 (1 + \Delta_{x_I})^2 + y_0^2 (1 + \Delta_{y_I})^2 \end{aligned} \quad (11)$$

Introducing

$$u = (1 + \Delta_{x_I})^2 \quad v = (1 + \Delta_{y_I})^2 \quad (12)$$

we find from Fig. 2^I

$$(r'/r_0)^2 = u \sin^2 \eta + v \cos^2 \eta \quad (13)$$

Since $\tan^2 \eta = \frac{v}{u} \tan^2 \xi$, we find from (13), using $\sin^2 \eta = \tan^2 \eta (1 + \tan^2 \eta)^{-1}$ and $\cos^2 \eta = (1 + \tan^2 \eta)^{-1}$ that

$$\delta_{r_I} = \frac{1}{2} \ln uv + \frac{1}{2} \ln(1 + \tan^2 \xi) - \frac{1}{2} \ln(u + v \tan^2 \xi) \quad (14)$$

For the second stage of strain we find

$$\delta_{r_{II}} = \ln r/r' = \ln(\cos \xi / \cos \nu) \quad (15)$$

$$\delta_{r_{II}} = -\ln \cos \nu - \frac{1}{2} \ln(1 + \tan^2 \xi) \quad (16)$$

Hence, using (9) and (14) we find

$$\delta_r = \frac{1}{2} \ln uv - \ln \cos \nu - \frac{1}{2} \ln(u + v \tan^2 \xi) \quad (17)$$

But, since in Fig. 2^{II} we have $D'D = E'E$, or $D'E = D'D + D'E'$, we see that $\tan \xi = \tan \nu - \tan \gamma$.

Introducing

$$\tan \gamma = w \quad (18)$$

it follows that

$$\delta_r = \frac{1}{2} \ln uv - \ln \cos \nu - \frac{1}{2} \ln \{ u + v(\tan \nu - w)^2 \} \quad (19)$$

We have now expressed δ_r in (u, v, w) which determine the strain of the element and in ν which determines the direction of an arbitrary line in this element. Hence, the principal strains are found by requiring that

$$\frac{d\delta_r}{d\nu} = 0 \quad (20)$$

from which we derive

$$\tan^2 \nu - \left(\frac{u}{vw} + w - \frac{1}{w} \right) \tan \nu - 1 = 0 \quad (21)$$

Introduce

$$\frac{u}{vw} + w - \frac{1}{w} = 2p. \quad (22)$$

The principal directions are then given by

$$\begin{aligned}\tan v_1 &= p + (1+p^2)^{\frac{1}{2}} \\ \tan v_2 &= p - (1+p^2)^{\frac{1}{2}}\end{aligned}\quad (23)$$

Substitution in (19) yields

$$\delta_1 = \frac{1}{2} \ln \frac{uv \left[1 + \left\{ p + (1+p^2)^{\frac{1}{2}} \right\}^2 \right]}{u+v \left\{ p - w + (1+p^2)^{\frac{1}{2}} \right\}^2} \quad (24)$$

$$\delta_2 = \frac{1}{2} \ln \frac{uv \left[1 + \left\{ p - (1+p^2)^{\frac{1}{2}} \right\}^2 \right]}{u+v \left\{ p - w - (1+p^2)^{\frac{1}{2}} \right\}^2}$$

And from Fig. 2^I it can be seen that

$$\delta_3 = -\frac{1}{2} \ln uv \quad (24a)$$

Next, the stresses that caused the strain as given in Fig. 1 are calculated. We will assume that the stresses are built up in such a way that their ratios remain constant during the entire process. Thomsen [2] proved that in this case eq. (3) may be integrated to the Hencky equations for principal directions, viz.

$$\delta_1 = \frac{\bar{\delta}}{\sigma} \left(\sigma_1 - \frac{\sigma_2 + \sigma_3}{2} \right), \text{ cyclic} \quad (25)$$

in which

$$\bar{\delta} = \left\{ \frac{2}{3} (\delta_1^2 + \delta_2^2 + \delta_3^2) \right\}^{\frac{1}{2}} \quad (26)$$

Numerical example.

We will assume that $\gamma = 60^\circ$, $\Delta_{x_I} = 0.2$ and $\Delta_{y_I} = -0.3$.

We find $w = 1.73$; $u = 1.44$; $v = 0.49$; $p = 1.42$; $\tan v_1 = 3.16$, and

$$\left. \begin{aligned}\delta_1 &= 0.58 \\ \delta_2 &= -0.75 \\ \delta_3 &= 0.17\end{aligned} \right\} \bar{\delta} = 0.79 \quad (27)$$

(Notice that $\delta_1 + \delta_2 + \delta_3 = 0$, but $\delta_x + \delta_y + \delta_z \neq 0$).
If $c = 1500 \text{ N/mm}^2$ and $m = 0.2$ then (6) gives $\bar{\sigma} = 1490 \text{ N/mm}^2$.
Solving the equations (25), we find, using $\sigma_1 + \sigma_2 + \sigma_3 = 0$ as an additional condition (since hydrostatic pressure does not influence the plastic straining).

$$\begin{aligned}\sigma_1 &= 730 \text{ N/mm}^2 \\ \sigma_2 &= -940 \text{ N/mm}^2 \\ \sigma_3 &= +210 \text{ N/mm}^2\end{aligned}$$

According to Fig. 3, in which we apply our hypothesis of coincidence of principal stress and strain, we find

(Fig.3)

Fig. 3. Mohr circle and state of strain according to Fig. 1.

$$\tan \nu_1 = \frac{\tau_{xy}}{\sigma_1 - \sigma_x} = 3.16$$

$$\left(\sigma_x - \frac{\sigma_1 + \sigma_2}{2}\right)^2 + \tau_{xy}^2 = \left(\frac{\sigma_1 - \sigma_2}{2}\right)^2$$

$$\sigma_1 - \sigma_x = \sigma_y - \sigma_z.$$

These equations yield, either by calculation or construction:

$$\begin{aligned}\sigma_x &= 580 \text{ N/mm}^2 \\ \sigma_y &= -790 \text{ N/mm}^2 \\ \tau_{xy} &= 485 \text{ N/mm}^2\end{aligned}$$

Finally we would emphasise that the reliability of the results produced largely depends both on the accuracy of the experimental determination of the materials constants c and m , and on the degree of uniformity of the deformation process considered.

If the deformation process is not uniform, the continuum should be divided into elements which are so small that their deformation is approximately uniform.

In that case the preceding theory yields an approximate stress distribution.

Literature:

- [1] Contribution to the mechanics of machining, P.C. Veenstra, Paper to the CIRP Conference, Liège 1965.
- [2] Thomsen, Yang, Kobayashi: Plastic deformation in metal processing.

(Fig. 1)

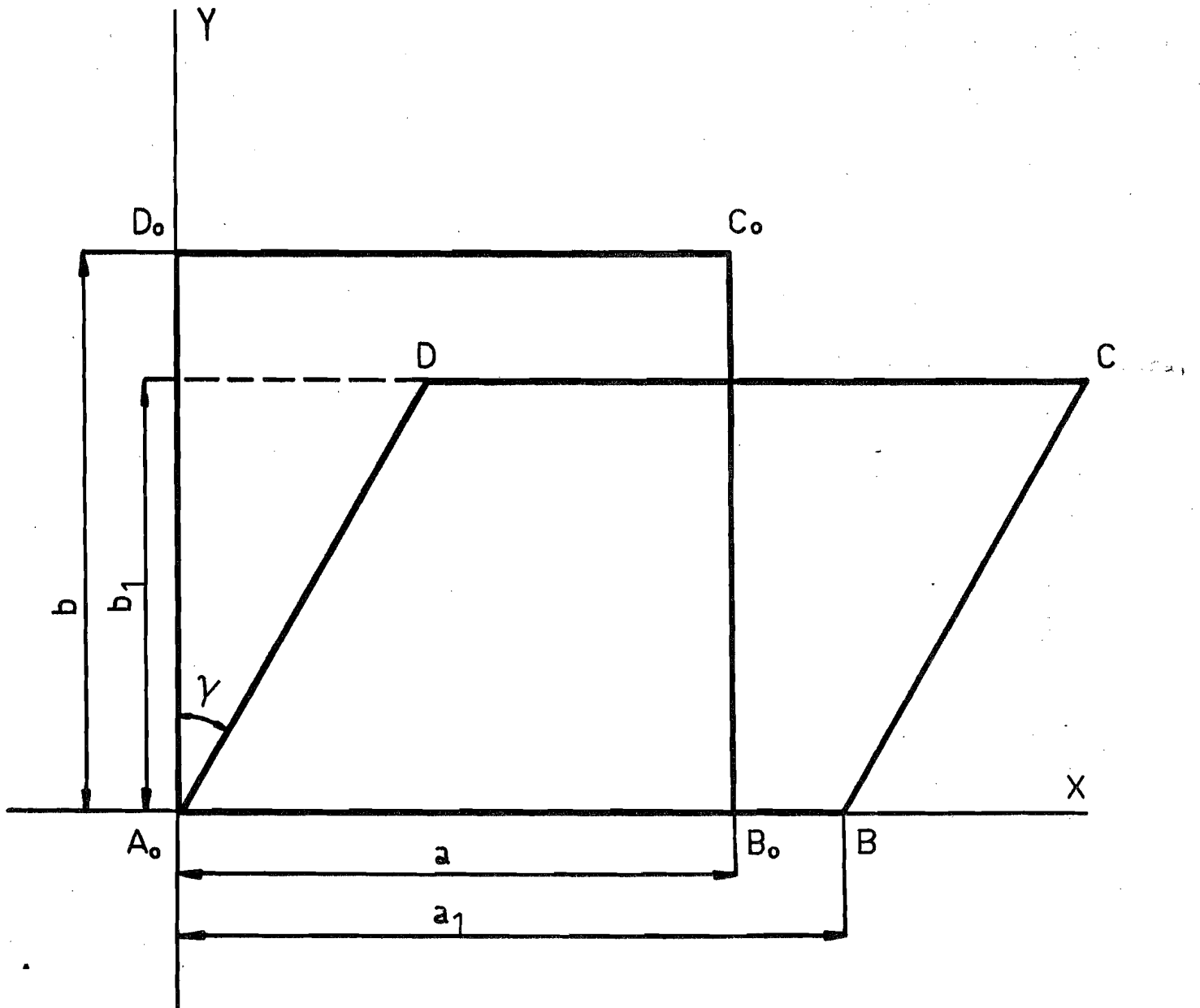

(Fig. 2)

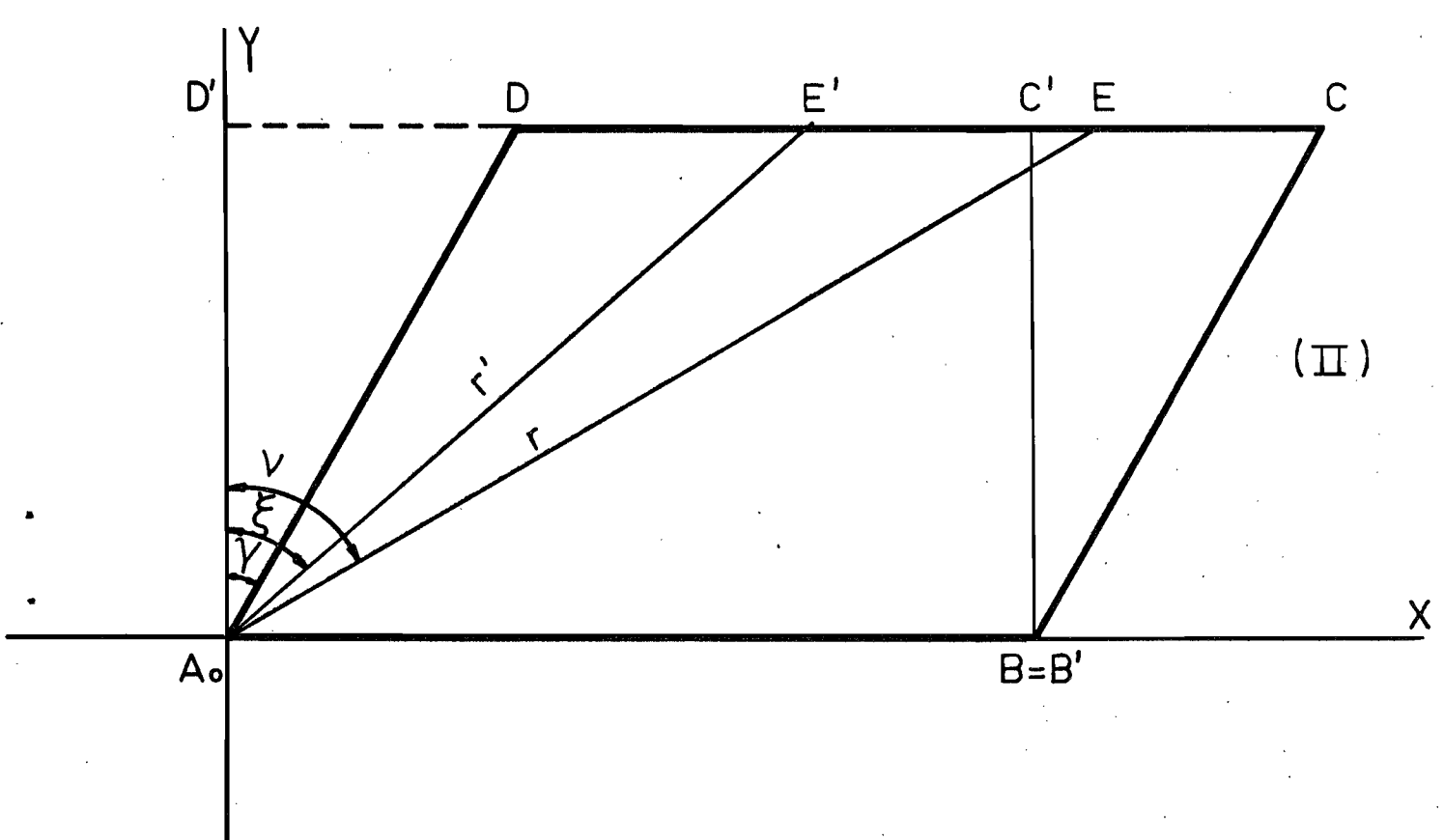
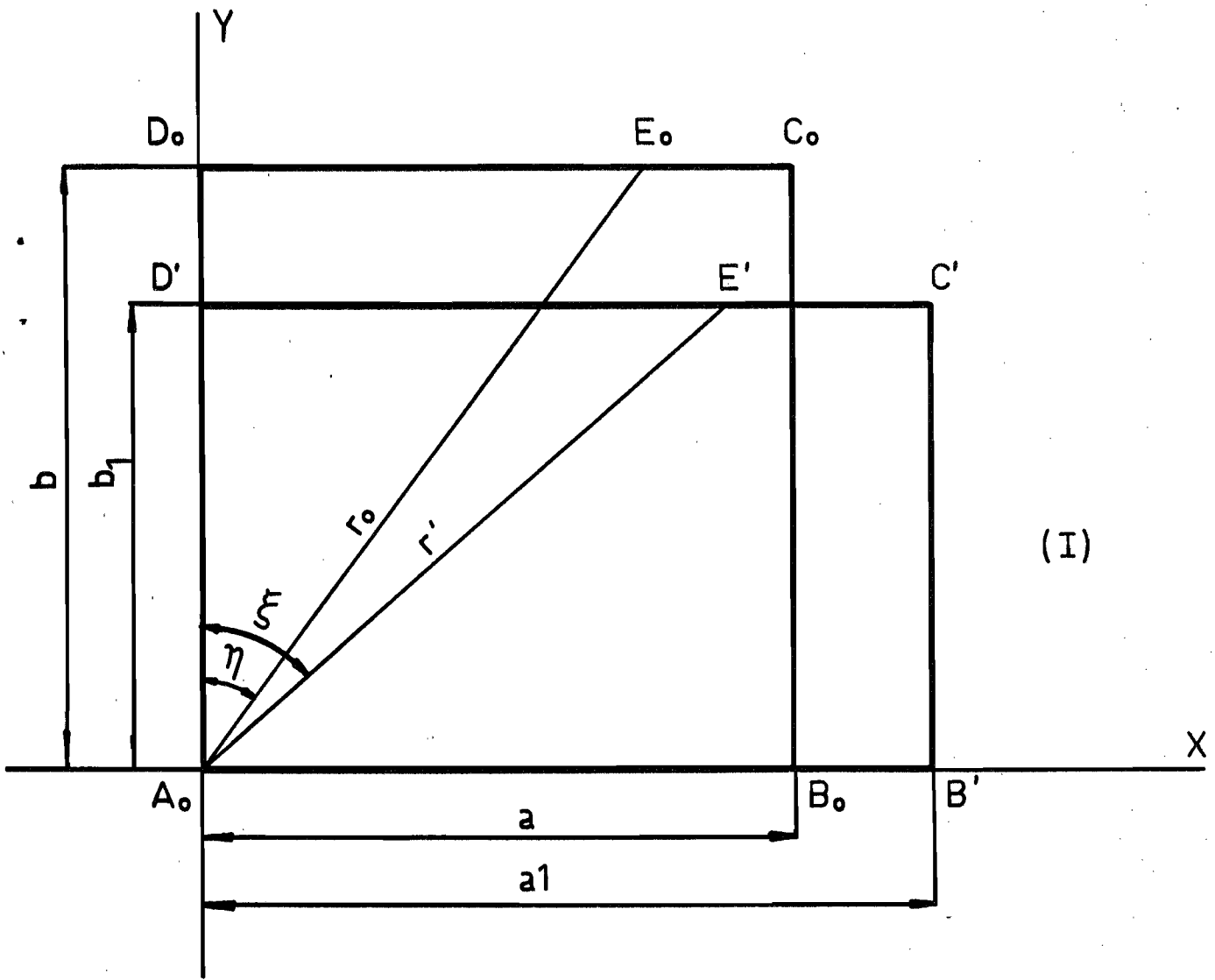

(Fig. 3)

