

Technische verspaning : voortgangsrapport : opzet praktikum 1 : Nube

Citation for published version (APA):

Schoot, van der, H. W. P. (1984). *Technische verspaning : voortgangsrapport : opzet praktikum 1 : Nube*. (TH Eindhoven. Afd. Werktuigbouwkunde, Vakgroep Produktietechnologie : WPB; Vol. WPB0130). Technische Hogeschool Eindhoven.

Document status and date:

Gepubliceerd: 01/01/1984

Document Version:

Uitgevers PDF, ook bekend als Version of Record

Please check the document version of this publication:

- A submitted manuscript is the version of the article upon submission and before peer-review. There can be important differences between the submitted version and the official published version of record. People interested in the research are advised to contact the author for the final version of the publication, or visit the DOI to the publisher's website.
- The final author version and the galley proof are versions of the publication after peer review.
- The final published version features the final layout of the paper including the volume, issue and page numbers.

[Link to publication](#)

General rights

Copyright and moral rights for the publications made accessible in the public portal are retained by the authors and/or other copyright owners and it is a condition of accessing publications that users recognise and abide by the legal requirements associated with these rights.

- Users may download and print one copy of any publication from the public portal for the purpose of private study or research.
- You may not further distribute the material or use it for any profit-making activity or commercial gain
- You may freely distribute the URL identifying the publication in the public portal.

If the publication is distributed under the terms of Article 25fa of the Dutch Copyright Act, indicated by the "Taverne" license above, please follow below link for the End User Agreement:

www.tue.nl/taverne

Take down policy

If you believe that this document breaches copyright please contact us at:

openaccess@tue.nl

providing details and we will investigate your claim.

BB 432442

VERTROUWELIJK

TECHNISCHE VERSPANING

Voortgangsrapport
Opzet praktikum 1: NuBe.

Auteur: Ing. H.W.P. van der Schoot

WPB-Rapport nr. 0130 okt.'84

Trefwoord: Praktikum 1: NuBe.

In dec.'83-jan.-'84 heeft het praktikum NuBe voor de eerste maal "gedraaid" onder gebruikmaking van de opgaven uit WPB-Rapport nr. 0037 van sept.'83.

Gebleken is dat de collegestof uit produktietechnologie voor Serie- en Massafabricage, deel 2, bij de studenten niet voldoende doorgedrongen is, zodat een gedegen instructie voorafgaande aan het praktikum noodzakelijk is. In deze instructie wordt aanvullende stof behandeld die nodig is om te komen tot het schrijven van een werkstukprogramma.

Het schrijven van de programma's met potlood en gum blijkt een noodzakelijke fase in de praktikummiddag, die zijn "hoogtepunt" bereikt bij de machines.

Om in één (lange) middag zo ver te komen is een intensieve begeleiding nodig.

Ter waarborging van de instructieve waarde van het praktikum zijn in dit rapport drie nieuwe werkstukken opgenomen.

Mogelijke oplossingen zijn in dit rapport toegevoegd in de vorm van computerafdrukken van het RWT programmeersysteem (DNC).

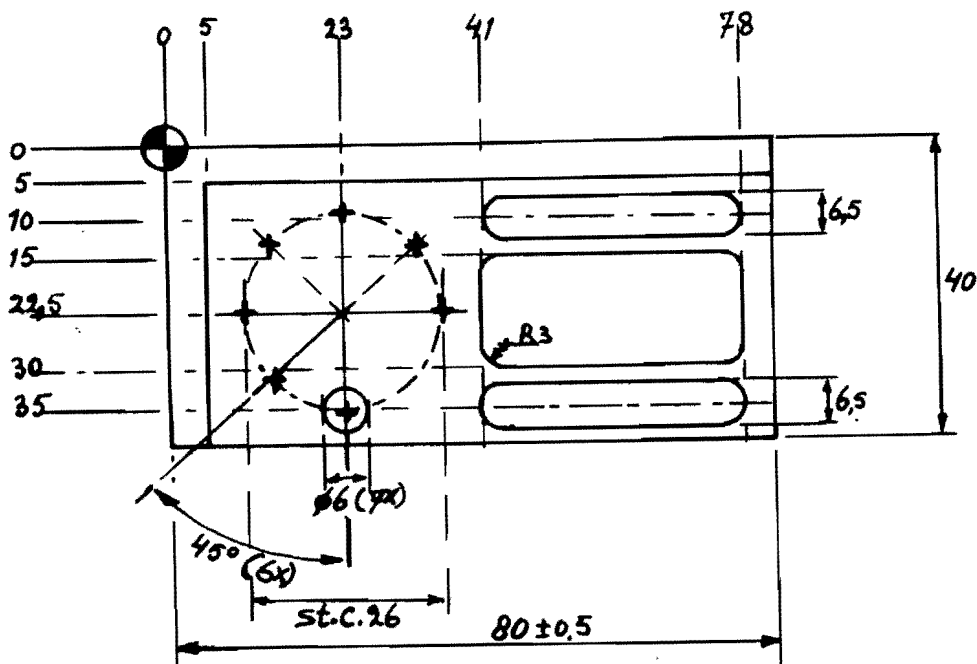

Werkstukoppervlak: X/2 vlak (frees in verticale kop)

Materiaal: messing strip 40x8 mm, lengte 80 mm \pm 0.5 mm.

Gereedschap: een spiebaanfrees ϕ 6.0 mm, lengte p.m.

Bewerkingsdiepte: alle gaten, spiebanen en kamers 3.8 mm

Toleranties: indien niet aangegeven \pm 0.05 mm

Diepteincrement: d mm (n.t.b.)

Veiligheidsafstand: a mm (n.t.b.)

Vrijsnijdtijd boorcyclus: 0.5 sec.

Voeding boren: 80 mm/min.

Voeding frezen: 160 mm/min.

Toerental hoofdspil: 2000 omw./min.

Gereedschapwisselpunt: Y=+100, X=-50, Z=+50

Bewerkingsvolgorde: n.t.b.

Identificatienummers bewerkingsvolgorde

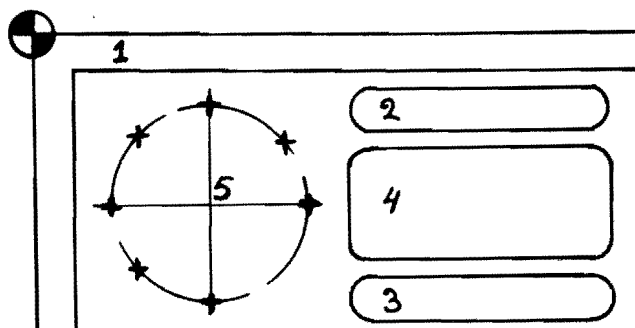

```
1: OPTIMIERT AM 05-OCT-84 14:58
2:
3: 1 TOOL DEF 1 L +0,000
4: 2 TOOL DEF 1 R +3,000
5: 3 A Y+100,000 R0 F9999 M
6: 4 A X-50,000 R0 F9999 M
7: 5 A Z+50,000 R0 F9999 M00
8: 6 TOOL CALL 1 Y S 1600,000
9: 7 A Y+2,000 R0 F9999 M03
10: 8 CYCL DEF 3.0 NUTENFRAESEN
11: 9 CYCL DEF 3.1 ABST -2,000
12: 10 CYCL DEF 3.2 TIEFE -3,800
13: 11 CYCL DEF 3.3 ZUSTLG-2,000
14: 12 CYCL DEF 3.4 X +6,500
15: 13 CYCL DEF 3.5 Z -28,000
16: 14 CYCL DEF 3.6 F154
17: 15 A Z+38,000 R+ F9999 M
18: 16 A X+5,000 R0 F9999 M99
19: 17 CYCL DEF 4.0 TASCHENFRAESEN
20: 18 CYCL DEF 4.1 ABST -2,000
21: 19 CYCL DEF 4.2 TIEFE -3,800
22: 20 CYCL DEF 4.3 ZUSTLG-2,000
23: 21 CYCL DEF 4.4 X +35,000
24: 22 CYCL DEF 4.5 Z +28,000
25: 23 CYCL DEF 4.6 F154
26: 24 A Z+24,000 R0 F9999 M
27: 25 A X+27,500 R0 F9999 M99
28: 26 CYCL DEF 1.0 TIEFBOHREN
29: 27 CYCL DEF 1.1 ABST -2,000
30: 28 CYCL DEF 1.2 TIEFE -3,800
31: 29 CYCL DEF 1.3 ZUSTLG-4,000
32: 30 CYCL DEF 1.4 V.ZEIT 0,200
33: 31 CYCL DEF 1.5 F80
34: 32 CYCL DEF 5.0 POL
35: 33 CYCL DEF 5.1 A X +63,000
36: 34 CYCL DEF 5.2 A Z +24,000
37: 35 CYCL DEF 6.0 POLAR-KOORD.
38: 36 CYCL DEF 6.1 A P.R.+11,000
39: 37 CYCL DEF 6.2 A P.W.+0,000
40: 38 CYCL DEF 6.3 F9999 M99
41: 39 LBL 1
42: 40 CYCL DEF 6.0 POLAR-KOORD.
43: 41 CYCL DEF 6.1 A P.R.+11,000
44: 42 CYCL DEF 6.2 I P.W.+45,000
45: 43 CYCL DEF 6.3 F9999 M99
46: 44 CALL LBL 1 REP 6 /6
47: 45 A Z+5,000 R0 F9999 M
48: 46 A X+5,000 R0 F9999 M99
49: 47 LBL 2
50: 48 I X+10,000 R0 F9999 M99
51: 49 CALL LBL 2 REP 6 /6
52: 50 A Y+100,000 R0 F9999 M05
53: 51 A Z+50,000 R0 F9999 M
54: 52 A X-50,000 R0 F9999 M30
```

1: OPTIMIERT AM 05-OCT-84 14:06
2:
3: 1 TOOL DEF 1 L +0,000
4: 2 TOOL DEF 1 R +3,000
5: 3 A Y+100,000 R0 F9999 M
6: 4 A X-50,000 R0 F9999 M
7: 5 A Z+50,000 R0 F9999 M00
8: 6 TOOL CALL 1 Y S 1600,000
9: 7 A Y+2,000 R0 F9999 M03
10: 8 A X+81,000 R+ F9999 M
11: 9 A Z+5,000 R+ F9999 M
12: 10 A Y-2,000 R0 F100 M
13: 11 A X+5,000 R+ F100 M
14: 12 A Z+41,000 R+ F100 M
15: 13 A Y-3,000 R0 F100 M
16: 14 A Z+5,000 R+ F100 M
17: 15 A X+81,000 R+ F100 M
18: 16 A Y+2,000 R0 F9999 M
19: 17 CYCL DEF 3.0 NUTENFRAESEN
20: 18 CYCL DEF 3.1 ABST -2,000
21: 19 CYCL DEF 3.2 TIEFE -3,800
22: 20 CYCL DEF 3.3 ZUSTLG-2,000
23: 21 CYCL DEF 3.4 X +37,000
24: 22 CYCL DEF 3.5 Z +6,500
25: 23 CYCL DEF 3.6 F154
26: 24 A Z+10,000 R0 F9999 M
27: 25 A X+41,000 R- F9999 M99
28: 26 A Z+35,000 R0 F9999 M99
29: 27 CYCL DEF 4.0 TASCHENFRAESEN
30: 28 CYCL DEF 4.1 ABST -2,000
31: 29 CYCL DEF 4.2 TIEFE -3,800
32: 30 CYCL DEF 4.3 ZUSTLG-2,000
33: 31 CYCL DEF 4.4 X +37,000
34: 32 CYCL DEF 4.5 Z +15,000
35: 33 CYCL DEF 4.6 F154
36: 34 A Z+22,500 R0 F9999 M
37: 35 A X+59,500 R0 F9999 M99
38: 36 CYCL DEF 1.0 TIEFBOHREN
39: 37 CYCL DEF 1.1 ABST -2,000
40: 38 CYCL DEF 1.2 TIEFE -3,800
41: 39 CYCL DEF 1.3 ZUSTLG-4,000
42: 40 CYCL DEF 1.4 V.ZEIT 1,000
43: 41 CYCL DEF 1.5 F80
44: 42 CYCL DEF 5.0 FOL
45: 43 CYCL DEF 5.1 A X +23,000
46: 44 CYCL DEF 5.2 A Z +22,500
47: 45 CYCL DEF 6.0 POLAR-KOORD.
48: 46 CYCL DEF 6.1 A P.R.+13,000
49: 47 CYCL DEF 6.2 A P.W.+0,000
50: 48 CYCL DEF 6.3 F9999 M99
51: 49 LBL 1
52: 50 CYCL DEF 6.0 POLAR-KOORD.
53: 51 CYCL DEF 6.1 A P.R.+13,000
54: 52 CYCL DEF 6.2 I P.W.-45,000
55: 53 CYCL DEF 6.3 F9999 M99
56: 54 CALL LBL 1 REP 5 /5
57: 55 A Y+100,000 R0 F9999 M05
58: 56 A Z+50,000 R0 F9999 M
59: 57 A X-50,000 R0 F9999 M30

F w t - NC-EDITOR PROGRAMM VMH4F 1006

1: OPTIMIERT AM 05-OCT-84 14:32
2:
3: 1 TOOL DEF 1 L +0,000
4: 2 TOOL DEF 1 R +3,000
5: 3 A Y+100,000 R0 F9999 M
6: 4 A X-50,000 R0 F9999 M
7: 5 A Z+50,000 R0 F9999 M00
8: 6 TOOL CALL 1 Y S 1600,000
9: 7 A Y+2,000 R0 F9999 M03
10: 8 A X+81,000 R+ F9999 M
11: 9 A Z+5,000 R+ F9999 M
12: 10 A Y-2,000 R0 F100 M
13: 11 A X+5,000 R+ F100 M
14: 12 A Z+41,000 R+ F100 M
15: 13 A Y-3,000 R0 F100 M
16: 14 A Z+5,000 R+ F100 M
17: 15 A X+81,000 R+ F100 M
18: 16 A Y+2,000 R0 F9999 M
19: 17 CYCL DEF 3.0 NUTENFRAESEN
20: 18 CYCL DEF 3.1 ABST -2,000
21: 19 CYCL DEF 3.2 TIEFE -3,800
22: 20 CYCL DEF 3.3 ZUSTLG-2,000
23: 21 CYCL DEF 3.4 X -69,000
24: 22 CYCL DEF 3.5 Z +6,500
25: 23 CYCL DEF 3.6 F154
26: 24 A Z+35,250 R0 F9999 M
27: 25 A X+77,000 R+ F9999 M99
28: 26 CYCL DEF 4.0 TASCHENFRAESEN
29: 27 CYCL DEF 4.1 ABST -2,000
30: 28 CYCL DEF 4.2 TIEFE -3,800
31: 29 CYCL DEF 4.3 ZUSTLG-2,000
32: 30 CYCL DEF 4.4 X +27,000
33: 31 CYCL DEF 4.5 Z +23,000
34: 32 CYCL DEF 4.6 F154
35: 33 A Z+18,500 R0 F9999 M
36: 34 A X+63,500 R0 F9999 M99
37: 35 CYCL DEF 1.0 TIEFBOHREN
38: 36 CYCL DEF 1.1 ABST -2,000
39: 37 CYCL DEF 1.2 TIEFE -3,800
40: 38 CYCL DEF 1.3 ZUSTLG-4,000
41: 39 CYCL DEF 1.4 V.ZEIT 1,000
42: 40 CYCL DEF 1.5 F80
43: 41 CYCL DEF 5.0 POL
44: 42 CYCL DEF 5.1 A X +20,000
45: 43 CYCL DEF 5.2 A Z +18,500
46: 44 CALL LBL 1 REP
47: 45 CYCL DEF 5.0 POL
48: 46 CYCL DEF 5.1 A X +38,000
49: 47 CYCL DEF 5.2 A Z +18,500
50: 48 LBL 1
51: 49 CYCL DEF 6.0 POLAR-KOORD.
52: 50 CYCL DEF 6.1 A P.R.+9,000
53: 51 CYCL DEF 6.2 A P.W.+30,000
54: 52 CYCL DEF 6.3 F9999 M99

55: 53 LBL 2
56: 54 CYCL DEF 6.0 POLAR-KOORD.
57: 55 CYCL DEF 6.1 A P.R.+9,000
58: 56 CYCL DEF 6.2 I P.W.-60,000
59: 57 CYCL DEF 6.3 F9999 M99
60: 58 CALL LBL 2 REP 3 /3
61: 59 LBL 0
62: 60 A Y+100,000 R0 F9999 M05
63: 61 A Z+50,000 R0 F9999 M
64: 62 A X-50,000 R0 F9999 M30