

**MASTER**

**Design of spare parts networks at a leading network equipment provider**

Arts, R.M.J.

*Award date:*  
2010

[Link to publication](#)

**Disclaimer**

This document contains a student thesis (bachelor's or master's), as authored by a student at Eindhoven University of Technology. Student theses are made available in the TU/e repository upon obtaining the required degree. The grade received is not published on the document as presented in the repository. The required complexity or quality of research of student theses may vary by program, and the required minimum study period may vary in duration.

**General rights**

Copyright and moral rights for the publications made accessible in the public portal are retained by the authors and/or other copyright owners and it is a condition of accessing publications that users recognise and abide by the legal requirements associated with these rights.

- Users may download and print one copy of any publication from the public portal for the purpose of private study or research.
- You may not further distribute the material or use it for any profit-making activity or commercial gain

Eindhoven, August 2010

**Design of Spare Parts Networks at a  
Leading Network Equipment  
Provider**

by  
Roy M.J. Arts

BSc Industrial Engineering and Management — Eindhoven University of Technology 2008  
Student identity number 0571945

in partial fulfilment of the requirements for the degree of

Master of Science  
**in Operations Management and Logistics**

Supervisors:

Prof. dr. ir. G.J. van Houtum, TU/e, OPAC

dr.ir. R.A.C.M. Broekmeulen, TU/e, OPAC

dr.ir. M. van Vuuren CSCP, CQM, Chain Management

dr.ir. A.A. Kranenburg MTD, CQM, Chain Management

A. Maas

TUE. Department Industrial Engineering & Innovation Sciences.  
Series Master Theses Operations Management and Logistics

Subject headings: Spare parts, Inventory control, Multi-locations, Multi- delivery time requirements, Lateral transshipments, Network design, Service logistics, “Service logistiek”

## ***Confidentially and Readability Note***

*This report studies the spare parts network design of a Leading Network Equipment Provider (LNEP) in which a leading Transport and Logistics Provider (TLP) is involved, both the company names are replaced with the abbreviations LNEP and TLP. In this public report the findings and results are presented without stating absolute costs.*

# **I Abstract**

This master thesis describes the research on the spare parts network design of a Leading Network Equipment Provider (LNEP). We study alternative network designs with regional warehouses. Lateral transshipments are taken into account during both inventory level determination and network design analysis. We investigate which network performs best. Furthermore, the influences of the different cost factors are investigated.

## II Management Summary

This report is the result of a Master thesis project at CQM with as subject the spare parts network of a Leading Network Equipment Provider (LNEP). LNEP offers high quality after sales-sales services. Customers expect spare part deliveries within 2 or 4 hour or the next business day. Currently, the spare parts network of LNEP consists of one European distribution center and many local spare parts centers. Furthermore, LNEP has completely outsourced the logistic operations and warehousing. The central European Distribution Centre (EDC) is managed by a local logistic service provider. Another logistic service provider does the transportation from the EDC to the Spare Parts Centers (SPC). Finally, the operations at the SPC are executed by a leading Transport and Logistic Provider (TLP). Both the EDC and SPC are not owned by LNEP but property of the logistic service provider. Inventory levels are managed by LNEP and customer delivery is executed by the express network service of TLP or a dedicated courier. The 145 locations for the SPCs are based on the customers of LNEP. If a customer places an order this has to be fulfilled within 2 or 4 hours or the next business day or the customer and LNEP schedule the delivery (often when 2 or 4 hours are impossible.)

We did research on the performance of the current European spare parts network design compared to a network with an extra echelon: a regional distribution center. The study has been conducted for LNEP and their logistic service provider TLP which manages the local spare part centers. The assignment has been formulated as:

*“Development of a model which will give insight in spare parts logistics and the ability to improve the current spare parts network design.”*

### Current spare parts network design

The current network has been designed by LNEP and TLP. The locations of the SPCs are determined by TLP and chosen based on the LNEP customer install base and the desired delivery performance to those customers. Changing local spare parts centres (SPC) locations and/or the European distribution centre (EDC) in Helmond is out of scope of the project. Customers can be served from one or more SPCs. If the nearest SPC is not able to fulfil the demand another near SPC will deliver. A shipment from a SPC which is not the SPC to which the customer is allocated, is called a lateral transshipment.

### Research Questions

The spare parts business can be characterised with low demand rates and high SKU costs. In our case both characteristics hold. Recent research has shown that inventory cost in spare parts networks is an important cost factor that should be taken into account for determining the *optimal* design of a spare parts network. Furthermore, in literature models for the integrated problem and focusing on regional and central distribution centers have not yet been studied. Possible reconfigurations of the current spare parts network could include regional or country

DC's which could be placed between the EDC and SPCs. Those regional DC's could for example replenish the SPCs. Other policies with a regional DC could be that next business day customers will be served from the country DC which will increase the inventory pooling effect. Consequently, the research questions for this thesis are stated as follows:

- I Is it for LNEP beneficial to use regional or country DC's and if: how, how many and where?
- II What is the influence of taking, next to strategic, tactical cost into account for the design of a spare parts network?
- III What is the influence and sensitivity of the different cost factors on the *optimal* spare parts network design?

## **Methodology**

To answer the research question and fulfill the assignment, a model has been designed to evaluate different network designs. Geographical locations of the regional distribution centers (RDCs) are chosen based on replenishment leadtime and distance to all customers in the region. Furthermore, inventory levels for the different situations were determined with the inventory model of Reijnen et al. (2009) and with a modified procedure on Reijnen et al. (2009). We used the model of Reijnen et al. (2009) because of the lateral transshipment allowance and time based service levels (e.g. 2 hour, 4 hour and next business day.)

## **Conclusion and Recommendations**

From the results of the model and methods, it can be concluded that using an RDC in the UK would perform the best in terms of costs. Additionally, RDCs in the other regions (Nordic and Iberia) would perform the best in terms of costs. The scenario with only an RDC in the UK outperforms the current two-echelon scenario on service levels and costs. Based on the fact that this scenario outperforms on service level we can assume that inventory can be decreased which will further decrease the total cost. Furthermore, emergency costs were not taken into account, and it can be assumed that in a three-echelon scenario an emergency shipment sometimes can be fulfilled from the RDC. This will be less costly than an emergency shipment from outside the region (from the EDC). Based on this and the fact that we found a three-echelon scenario which outperforms on both cost and service level, we can recommend using an RDC in the UK. However, a low percentage in total cost reduction was found of only 2%. A percentage of 2% is quite low but we expect that this percentage can increase if the inventory policies would be further optimized. Furthermore, the current 2% reduction would be achieved by changing the network design in one of the regions in the EU theatre. Secondly, we expect the demand to increase which will increase the number of items which would be held on stock at the RDC and thus the benefits of an RDC. Additionally, from a sustainability perspective, a three-echelon scenario performs better due to the shift from air to road transport. Besides that, if for example a fire or ash cloud makes distribution from the EDC impossible the three

echelon scenario is less sensitive for such risks. Finally, it is recommended to change the network design for the UK region into a three-echelon network. Furthermore, based on the results of the model and methods we can conclude on the research questions as follow:

***I Is it for LNEP beneficial to use regional or country DC's and if: how, how many and where?***

From the two- and three echelon scenario comparisons we can conclude that there are three-echelon scenarios for some regions which are beneficial in terms of cost and or service level performance. As replenishment policy we would suggest using the standard/road network and the answer on the “*how many*” question we can conclude maximal one per TLP region. The answer on the *where* question would be: a city, reachable with a two business day leadtime via the standard/road network and a city which is centrally located for emergency and courier shipment for which the costs are distance based.

***II What is the influence of taking, next to strategic, tactical cost into account for the design of a spare parts network?***

Successful supply chain management requires decisions on three traditional hierarchical levels and with respect to three time horizons: (1) strategy or design, (2) tactical or planning, and (3) operations (Chiani et al. 2004). The research on supply chain management for spare parts is mainly limited to the tactical and operational level (e.g. inventory, service or forecasting) (Wagner and Lindemann, 2008). An important decision at the strategic level for service supply chains is the number and geographical position of locations and its demand allocation. From our results we can conclude that if we would not take the tactical cost: of holding inventory into account we would end up with the conclusion that three-echelon network will outperform a two-echelon network. This research did take inventory holding costs into account which made it possible to draw a more nuanced conclusion. Based on this thesis it can be stated that the influence of taking the tactical cost factor inventory into account during spare parts network design is very important.

***III What is the influence and sensitivity of the different cost factors on the optimal spare parts network design?***

From the sensitivity analyses, it could be concluded that the inventory rent percentage has a minor influence on the interpretation and conclusion of the results. Furthermore, the transport rates do have an influence on the difference in costs between a two- and a three-echelon scenario. If transport rates increase the three-echelon scenarios will relatively perform better and vice versa. Additionally, from the sensitivity analysis on the cost of an emergency shipment it is concluded that the bigger the difference between the cost of an emergency shipment within the region (from an RDC) and from outside the region (EDC) the more the three-echelon network is favourable. Furthermore, the higher the level of emergency shipments costs the more a three-echelon scenario gets in favour of a two-echelon scenario in terms of cost.



### III Preface

This master thesis is the final piece of my study Industrial Engineering and Management. In this master thesis I focus on service logistics.

I would like to use this opportunity to express my gratitude to my supervisors. I would like to thank Geert-Jan van Houtum for his supervision during my master. His enthusiasm and knowledge made our meetings pleasant and really helped me moving on during the project. During my literature review and the early phases of the project, I worked closely with Ingrid Reijnen, AIO at Eindhoven University of Technology. I really appreciate the time and effort she spent on giving me feedback on my literature review. Next, I would also like to thank Rob Broekmeulen, my second supervisor for his feedback on my reports.

I would like to thank Bram Kranenburg and Marcel van Vuuren for being my daily supervisors at CQM for the pleasant office days and motivating meeting. Furthermore, I would like to thank Antal Maas for helping me collecting data, his feedback and facilitating efforts during the project. For the interesting and valuable conference calls I would like to thank Ray Ridyard and Frank Hofstee. Moreover, I would like to thank all people at CQM and my internship colleagues.

I owe many thanks to my parents for their continuing support that allowed me to become who I am. Finally, I would like to thank my girlfriend and friends for their support during my study. You made sure that I enjoyed this time!

Roy Arts

# IV Contents

I	Abstract.....	iii
II	Management Summary.....	iv
III	Preface .....	vii
IV	Contents.....	viii
o	Introduction .....	I
I	Research Assignment.....	2
I.1	Companies involved.....	2
I.1.1	LNEP.....	2
I.1.2	TLP.....	3
I.1.3	CQM .....	3
I.2	Service network.....	3
I.2.1	Structure and process .....	3
I.2.2	Geographical Scope: “EU Theatre” .....	5
I.2.3	Demand and Inventory.....	6
I.2.4	Control .....	7
I.4	The problem statement.....	7
I.4.1	Problem context and business environment.....	8
I.4.2	Research questions .....	9
I.4.3	Project scope.....	10
I.5	Outline of the report .....	11
2.	Model.....	12
2.1	Two-echelon network.....	12
2.1.1	Customers .....	13
2.1.2	SPCs.....	13
2.1.3	European Distribution Centre.....	14
2.1.4	Order fulfilment process .....	15
2.1.5	SPC Replenishment.....	17
2.1.6	Parameters.....	17
2.2	Three-echelon network .....	19

2.2.1	Customers .....	19
2.2.2	SPCs.....	20
2.2.3	RDC.....	20
2.2.4	European Distribution Centre.....	20
2.2.5	Order fulfilment process .....	21
2.2.6	SPC Replenishment.....	22
2.2.7	RDC Replenishment.....	22
3.	Method.....	23
3.1	Scenarios.....	23
3.2	Demand distribution .....	26
3.3	Inventory.....	26
4.	Results .....	32
4.1	Design of experiment .....	32
4.2	Initial design results .....	33
4.3	Modified design results .....	37
4.4	Sensitivity analysis .....	40
4.4.1	Emergency shipment costs.....	41
4.5	Conclusion.....	42
5.	Conclusion and recommendations.....	44
5.1	Conclusion.....	44
5.3	Recommendations for the LNEP network.....	45
5.2	Recommendations for further scientific research .....	46
	References .....	47
	List of concepts.....	48
	List of abbreviations .....	49

## o Introduction

Producers of expensive machines that are intensively used are more and more confronted with the difficult task to maintain the machines and guarantee high system availability. The failure of just one component in such complex machines can cause a system breakdown and because downtimes are costly customers negotiate a service contract. Consequently, spare part inventories are required to keep the average downtime as low as possible. However, most spare parts are quite expensive, therefore excessive spare part stock should be avoided. Maintaining an effective level of parts inventory is, according to a recent study of the Aberdeen Group, one of the two top challenges for companies engaged in spare parts services (Aberdeen Group, 2008). Getting the right part to the right place at the right time dramatically impacts a service organization's margins as well as its customer satisfaction metrics. As a result, parts management is a critical and integral component in the strategic service chain. In fact, recent studies revealed that after-sales services and the selling of spare parts contribute roughly 25% to the revenues and 40 to 50% to the profits of manufacturing and engineering-driven firms (Dennis et al., 2007), (Cohen, 2003). The economic importance of the spare parts business is also underlined by the fact that the aftermarket for spare parts and services accounts for 8% of the annual gross domestic product of the USA.

In this thesis a research on LNEP spare parts network design is conducted. Currently, the spare parts network of LNEP consists of one European distribution centre and many local spare parts centers. LNEP is questioning if the use of regional distribution centers would be beneficial and in this thesis we will discuss this network design issue. In preparation of this master thesis project two preliminary studies have been conducted. First of all, a literature review on design of spare parts networks (Arts, 2010a). The second preliminary study is the research proposal (Arts, 2010b) that contains an outline of the current spare parts network and policies at LNEP, the formulation of the assignment and the scope of the assignment.

The two preliminary studies are input for the first chapter. This chapter will give an introduction of the context in which the study is conducted and formulates the research assignment.

The remaining part of the report can be split into two parts. In the first part the model and method that are used to execute the research are described. The second part includes the results, conclusions and recommendations. An extensive outline of these two parts of the report is given at the end of Chapter 1.

It should be noticed that in this public report most of the data is transformed to normalized values, which are of equal value for comparisons but hide sensitive business values.

# **I Research Assignment**

This first chapter gives an overview of the research assignment. In Section 1.1, we give an introduction of the companies which are involved in the project. Section 1.2 presents the structure, processes, control and design of the current spare parts network of LNEP. Next, the problem statement is described in Section 1.3. Finally, an outline of the remainder of the report is given.

## **1.1 Companies involved**

CQM is the first company involved in the project. TLP is a customer of CQM and internal consultants of TLP became interested in the project via CQM. TLP wants to offer its customers the best complete supply chain solutions possible. Consequently, TLP is eager to get new insights in the field of spare parts networks. TLP hopes to be able to make better or innovative business solutions to its customers as result of this project. TLP has no own spare parts and capital goods. Consequently, a business partner of TLP was needed which does own capital goods and which we could use as real life business case. TLP found LNEP as producer of capital goods willing to cooperate in the project. In the remainder of this subsection an introduction of all three companies involved is presented. It is strength of the project that both an OEM and logistic service provider are participating and providing information.

### **1.1.2 LNEP**

### **1.1.2 TLP**

### **1.1.3 CQM**

CQM is the acronym of Consultants in Quantitative Methods. The consultants of CQM believe that the use of quantitative models increases the understanding of complex processes. Furthermore, this facilitates an understanding of potential improvements and successful realization of this potential is the next step, with the ultimate goal of structural improvement. CQM uses client-centered solution engineering in order to achieve a solution together with clients in short cycles. CQM does this based on facts, utilizing analytical techniques and mathematical models. The more than 30 consultants are divided in three groups: Chain Management, Planning, and Product and Process Improvement. This project has been executed within the Chain Management group.

## **1.2 Service network**

This section outlines the current distribution network of LNEP. First, the structure of the different stocking points in the network is described. Next, the order fulfillment and replenishment processes in the network are described.

### **1.2.1 Structure and process**

LNEP has completely outsourced the logistic operations as can be seen in Figure 1. The central European Distribution Centre (EDC) is managed by a local service provider. Another logistic service provider does the transportation from the EDC to the Spare Parts Centers (SPC). Finally, the operations at the SPC are executed by TLP. Both the EDC and SPCs are not owned by LNEP but property of the logistic service provider. Inventory levels are managed by LNEP and customer delivery is executed by the express network service of TLP or a dedicated TLP courier. The 145 locations for the SPCs are based on the customers of LNEP. If a customer places an order this has to be fulfilled within 2 or 4 hours or the next business day or the customer and LNEP schedule the delivery (often when 2 or 4 hours are impossible.) For the

premium service levels (2 or 4 hours) TLP accounts 15 minutes for order creation, 10 minutes processing, 20 minutes for warehouse pick-up and 75 or 195 minutes drive time. If TLP fails to serve a customer on time no penalty costs are paid, although it will influence the KPI performances. The achieved KPI's will influence future contract negotiations and the TLP commercial division could decide to give a discount based on bad KPI performances but there are no formal rules or costs stated based on KPI performance.

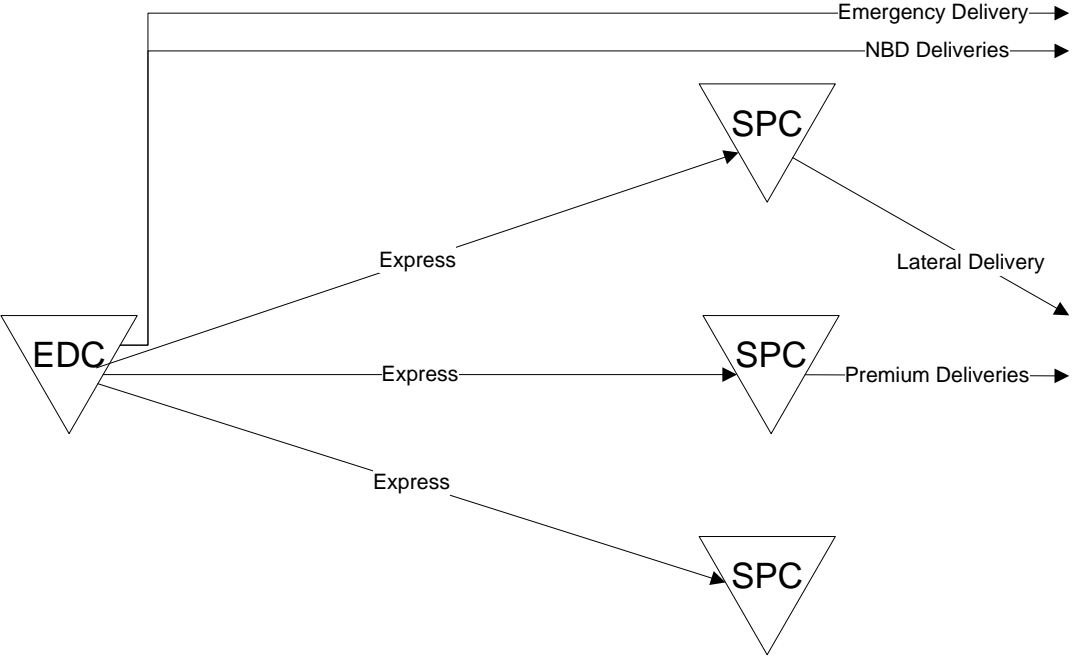

**Figure 1.1: Current service supply chain structure**

If a customer calls the LNEP call centre and places an order, LNEP knows and manages the stock at each SPC and will assign the customer demand to a (nearest) SPC. This SPC receives the order information from the call centre via a system message. Only the SPC which is allocated to the customer is allowed to fulfil its demand and if demand cannot be fulfilled the demand will be assigned to the next nearest SPC in the same country which can deliver. Additionally, lateral transshipments are only allowed within a country. If LNEP knows that none of the near SPCs can deliver, an emergency shipment is requested at the EDC. The inventory policy at the SPCs is a basestock policy, with a continuous review and a next business day replenishment leadtime. Next to shipments to the customers LNEP requests shipments between SPCs, these so-called allocation shipments can be considered as pro-active lateral transshipments or stock balancing. The leadtime of an allocation shipment is one business day and executed via the TLP express network.

For the European DC there are warehousing costs, costs for holding inventory and fixed/rent costs for the warehouse itself. The inventory levels and policy at the EDC are determined by

LNEP. The transport from the EDC to the SPCs is done by a logistic service provider and the costs are express parcel based (weight and volume combination, TLP benchmark rates will be used) and have a leadtime of one business day.

The current network has been designed by LNEP and TLP. The locations of the SPCs are determined by TLP and chosen based on the LNEP customer installed base and the desired delivery performance to those customers. Changing SPC locations and/or the EDC in Helmond is out of scope of the project. A schematic representation of the current service network design is presented in Figure 1.2, dotted arrows represent replenishment streams and straight lines represent customer deliveries. As can be seen from the figure customers can be served from one or more SPCs.

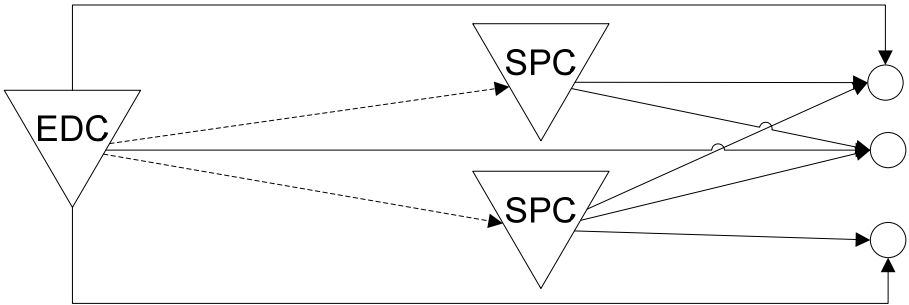

**Figure 1.2: Abstract current service network**

**1.2.2 Geographical Scope: “EU Theatre”**

Until 2010, TLP operated the SPCs for LNEP in 12 countries: Belgium, Cyprus, Denmark, France, Greece, Germany, Italy, Malta, Israel, Portugal, Spain (including Canary Islands) and Northern Ireland. In 2010, TLP started to operate SPCs in 11 other European countries: Austria, Finland, Gibraltar, Iceland, Ireland, Luxemburg, Netherlands, Norway, Sweden, Switzerland and the United Kingdom (including Jersey, Guernsey and Isle of Mann.) The new set of 23 countries is called the EU theatre and graphically presented in Figure 1.2. Each black country is part of the old TLP business and the gray countries represent the new acquired business for TLP. Furthermore, the locations of the SPCs are presented in Figure 3. In the new acquired countries, TLP warehouses are chosen which are close to the old Rapid Failure Depot (RFD) of LNEP which were managed by another logistics service provider.





Figure 1.2: EU Theatre



Figure 1.3: SPCs in South Europe

### 1.2.3 Demand and Inventory

In the EU theatre, there are 145 SPCs and in 2009 3,302 different spare parts were in the network. Inventory levels and demand rates are very low. For a significant number of SPCs the fulfilled demand in 2009 has been analysed and presented in Table 1.1: Fulfilled demand from SPCs . We analysed unique SPC-item combinations, so if item X was shipped to a customer from SPC A once in 2009 it counts for the first data row (yearly demand rate =1) and if it was shipped twice from A to a customer it would count for one in the second data row (yearly demand rate =2.) From Table 1.1 it can be concluded that 73% of the item-SPC combinations was only shipped once in 2009 and that there are many SKUs with very low demand rates.

Yearly demand rate	Percentage of SKU-warehouse combinations	
	Premium demand (2 and 4hour)	Standard demand (NBD)
1	73%	28%
2	16%	13%
3	6%	8%
4	2%	5%
5	1%	5%
6	1%	4%
7	<1%	3%
8	<1%	2%
9	<1%	2%
10	<1%	2%
11-20	<1%	9%
21-30	-	5%
31-50	-	5%
50-100	-	5%
100-1713	-	6%

**Table 1.1: Fulfilled demand from SPCs**

#### 1.2.4 Control

This section elaborates on the control of the network in terms of identification of activities that are outsourced and service measures that are used.

The distribution and warehousing is managed by 3PL providers. However, LNEP manages the process in terms of strategic planning, procurement and, inventory policies. To evaluate the performance of the system and to track the (expected) customer satisfaction, LNEP uses KPIs which are measured by TLP. Currently, the percentage on time shipments is considered as the most important KPI. The KPI is currently measured on country and/or EU level. TLP measures for LNEP in total 19 KPI's of which 9 are introduced in 2010, the three relevant KPI's for our project are listed in Table 1.2: LNEP KPI's.

KPI	Target level
2 Hour (on time)	97,50%
4 Hour (on time)	97,50%
Next Business Day Delivery (NBD)	97,00%

**Table 1.2: LNEP KPI's**

#### 1.4 The problem statement

This section first covers the general problem context as formulated in the research proposal. The second subsection discusses the current spare parts network and the currently undergoing changes. Finally, the research questions are presented.

### 1.4.1 Problem context and business environment

Recent research has shown that inventory cost in spare parts networks is an important cost factor which should be taken into account for determining the *optimal* design of a spare parts network (Reijnen et al., 2009). This can be explained by the strong interaction between the inventory and the traditionally defined strategic questions and the relative high inventory costs in the spare parts business. Furthermore, if fuel prices increase it will increase the importance of transportation costs and ordering policies, and it will affect an *optimal* design (more centralized versus de-centralized designs.) In a spare parts environment an integrated design approach, which includes inventory, compared to a decoupled design approach leads to a cost reduction and a different solution in terms of number and locations of regional and central distribution centers (Arts, 2010a). Also in literature, models for the integrated problem and focusing on regional and central distribution centers have not yet been analyzed or studied (Arts, 2010a). This motivated the project that studies the spare parts network design problem from a perspective of TLP customer LNEP.

Looking at the business environment there are some general trends notable. First of all, there are emerging markets relatively close or linked to the EU theatre. The EMEA region is for LNEP a strong growing market, the central distribution center for the EMEA countries (see Figure 1.4) is also located in Helmond and managed by a local logistic service provider. Formally, the EU DC and EMEA DC are separate but they both have the same physical location. Not only the EMEA market is still growing also the EU spare parts shipments of LNEP are growing.

Furthermore, environmental issues are becoming more important. Due to the increase in public pressure and governmental regulations more attention is paid to for example CO<sub>2</sub> emission. Companies like TLP have to develop innovative processes or products to operate more environmental friendly. An example of a new TLP product is the GoGreen shipment, a value-added service that offsets the CO<sub>2</sub> emissions caused by the transportation with carbon dioxide reduction projects ranging from alternative vehicle technologies to renewable fuels. The service was launched given the urgency of the fight against climate change. The shipping party has to pay something extra for a GoGreen shipment and the receiving party will see (via a sticker) that the packet was shipped environmentally neutral.



Figure 1.3: EU (black – in scope) and EMEA (gray – out of scope) market

#### 1.4.2 Research questions

In this project, we study the network design for spare parts of TLP customer LNEP where inventory-holding costs are explicitly taken into account. From literature review (Arts, 2010a), it has been concluded that recent research has shown that inventory cost in spare parts networks is an important cost factor that should be taken into account for determining the *optimal* design of a spare parts network. Furthermore, in literature models for the integrated problem and focusing on regional and central distribution centers have not yet been studied. This motivates a project that studies a real life spare parts network design problem from a perspective of a service logistic customer of TLP: LNEP. As described in Section 3, the current spare parts network consists of one EDC and many SPCs near to the customers and TLP is questioning this design. Possible reconfigurations of the network could include regional or country DC's which could be placed between the EDC and SPCs. Those regional DC's could for example replenish the SPCs. Other policies with a regional DC could be that next business day customers will be served from the country DC which will increase the inventory pooling effect. Many more policy and network configurations would be possible. Consequently, the research questions are stated as follow:

- *Is it for LNEP beneficial to use regional or country DC's and if: how, how many and where?*

- *What is the influence of taking, next to strategic, tactical cost into account for the design of a spare parts network?*
- *What is the influence and sensitivity of the different cost factors on the optimal spare parts network design?*

### 1.4.3 Project scope

The project will focus on the spare parts supply chain of LNEP items in the so-called EU theatre. Consequently, we do consider the multi-echelon structure from EDC to SPC and the replenishments of the SPCs. Next to replenishment costs, inventory carrying, transportation and warehouse handling related costs are considered. Locations of the potential regional and country DC's are variable and subject to the network design decision. The location and service level decisions for the SPCs are out of scope for optimization. An overview of the in and out of scope characteristics are presented in Table 1.3: In and out of scope characteristics.

<b>In scope</b>	<b>Out of Scope</b>
EU Theatre distribution network for replenishment of the stock in the SPCs	Location decisions for Spare Parts Centers (SPC)
Multi echelon network structure (Global, European, Regional and Country DC's)	Optimal service level decisions
Inventory carrying, transportation (fuel) and hub warehouse handling related costs	Extra man hour costs at SPC for special requests
Location and stock planning decisions for European, Regional and Country DC's	Pull-back allocations (end of life and defect spare parts)
Soft factors of a distribution network structure	Allocation of stock (pro-active lateral transshipments)
Emergency shipments	
Stock planning decisions for SPC	

**Table 1.3: In and out of scope characteristics**

## 1.5 Outline of the report

This section describes the structure of the remaining chapters in this report. These chapters can be categorized into 2 parts. In the first part the model and methods that are used to fulfill the research are described. The second part includes the results, conclusions and recommendations.

### Part I

Based on the approach defined in this chapter, Chapter 2 presents the basic models that are used to evaluate the different scenarios. In Chapter 3 the methodologies that are used to derive input for the basic models is presented. Furthermore, the scenarios to be analyzed and important assumptions are presented in Chapter 3.

### Part II

Chapter 4 presents the performances of the scenarios. These results provides insights into the best suited network design. Finally, conclusions and recommendations based on these results are presented in Chapter 6.

## 2. Model

This chapter describes the model that is used to answer the research questions which we discussed in the previous section. We have two basic models: a two- and a three-echelon model. Both basic structures can be operated with different policies and or parameters. A combination of a policy and parameters is called a scenario. In Subsection 2.1 we will describe the first basic structure of the two-echelon network and the same for the three-echelon structure is done in Subsection 2.2. The scenarios are defined in Chapter 3.

### 2.1 Two-echelon network

The basic structure of the two-echelon network is presented in Figure 2.4, the upstream warehouse is the EDC which replenishes the SPCs. The EDC also fulfils demand of customers which request the delivery on the next business day. The SPCs fulfil customer demand which have a requested leadtime of 2 or 4 hours. The models infrastructure consists of five main components: Customers, Spare Parts Centres (SPCs), the European Distribution Centre (EDC), SPC Replenishment and the order fulfilment process. In this order each of these five components is discussed in a subsection. In Subsection 2.1.1 the customers are described, followed by the SPCs in Subsection 2.1.2 and the EDC in 2.1.3. Next, the order fulfilment and SPCs replenishment processes are described in Subsection 2.1.4 and 2.1.5.

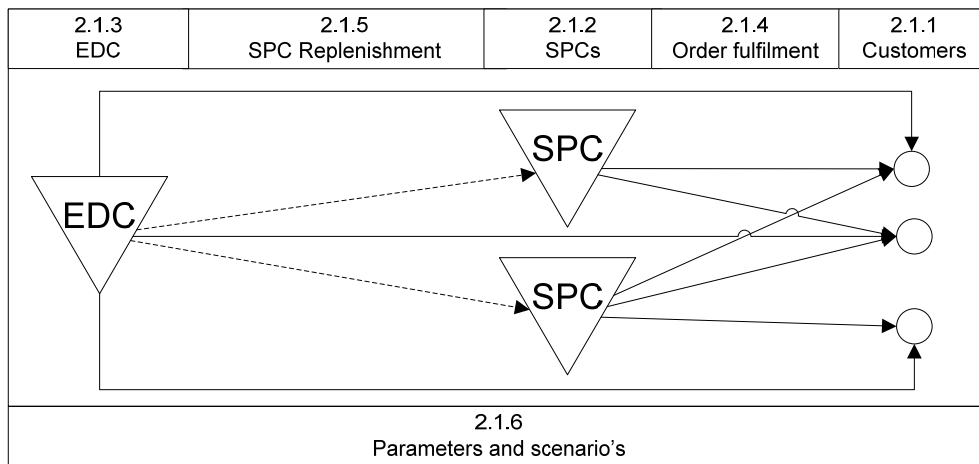

**Figure 2.4: Two-echelon basis structure**

The model has periods of one business day, each period starts at 08:00h and will end at 17:00h. If one period is finished the next period starts immediately afterwards (e.g. 17:00h of period x and 08:00h of period x+1 are the same.) A graphical representation of the time is given in Figure 2.5.

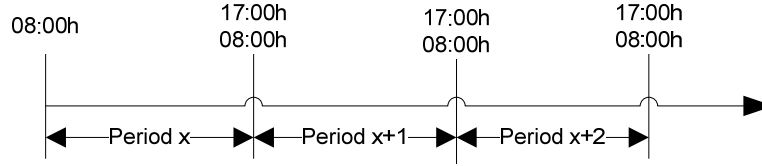

**Figure 2.5: Timeline**

### 2.1.1 Customers

LNEP knows its customers and has a service contract with them; this can be a premium or standard contract. A premium contract means that LNEP should be able to deliver within 2 or 4 hours and for standard customers this should be the Next Business Day (NBD). We define three customer types: NBD, 2h and 4h and the set of these customer types is defined by  $S$ . If demand enters the LNEP network, the following has to be known: delivery location, customer type and item. Based on the first two characteristics, the demand is allocated to a warehouse. In our model we consolidate all customers into a 2-digit postal code level and treat each 2-digit postal code, customer type and item combination as a unique demand stream. For example, if there would be a customer in Geldrop (postal code 5660) and Eindhoven (postal code 5600) which both have the same service requirement and item demand they will be modelled as one customer. The set of customer locations, denoted by  $C$ , is a set with 2-digit postal code areas.

We denote the set of SKUs by  $K$  and the set of weight classes by  $G$ . Furthermore, the value, volume and weight of each of these SKUs is known. In our model, for each SKU  $k \in K$ , we use the binary parameter  $W_k^w$  to indicate that SKU  $k \in K$  belongs to weight class  $w \in G$ . Furthermore, we use  $Vol_k$  for volume in  $m^3$  and  $V_k$  for the value in euro's of SKU  $k \in K$ . For each combination of delivery location, customer type and item we have a demand rate. One period is a business day from 08:00h till 17:00h with a continuous demand rate over each period. Furthermore, as parameters for demand rate we use:

$\lambda_{c,s,k}$  Demand rate of customer location  $c \in C$ , customer type  $s \in S$ , for item  $k \in K$

### 2.1.2 SPCs

The network consists of a set of warehouses denoted by  $W$ . The SPCs are part of the set of warehouses and do not have a restricted capacity. We introduce the binary variables,  $t_j^n$  and  $s_j$  to indicate if warehouse  $j$  is located in country  $n$  and if warehouse  $j$  is an SPC. The SPCs are mainly used for fulfilling demand of premium customers which require the spare part within 2 or 4 hours.

There are five relevant cost factors related to the SPCs which are presented in Table 2.4, the values of these cost vary per country. We define  $n \in N$  as the set of countries and we will use it



as superscript for parameters which vary per country. Handling costs are charged per in- and outbound order and per additional item in each order. If a SPC orders several items at the EDC for the next business day they can be put in the same order, so then the order contains more than one item. Basestock levels of the current 2-echelon network are known and based on historical demand.

We also use rent costs which are calculated over the value of the stored items. The SPCs use a basestock policy with the base-stock level for SKU  $k$  at SPC  $j$  indicated with parameter  $S_{j,k}$ .

Cost Type	Cost	Explanation
Inbound handling	$I_0^{n,SPC}$	Inbound handling cost per part (new order) in country $n \in N$
Inbound handling	$I_p^{c,SPC}$	Inbound handling cost per additional part thereafter in the same order in country $n \in N$
Outbound handling	$O_0^{n,SPC}$	Outbound handling cost per per part (new order) in country $n \in N$
Outbound handling	$O_p^{n,SPC}$	Outbound handling cost per additional part thereafter in the same order in country $n \in N$
Holding cost	$r$	Monthly rent cost on inventory value

**Table 2.4: SPC costs**

Furthermore, as parameters distance and drive time from SPCs to customers we use:

$d_{j,c}$  Distance in kilometres from SPC  $j \in W$  to customer location  $c \in C$

$dt_{j,c}$  Drive time in hours from SPC  $j \in W$  to customer location  $c \in C$

### 2.1.3 European Distribution Centre

We have one European Distribution Centre (EDC) which is located in Helmond (Sojadijk 4, 5704RL.) The EDC replenishes the SPCs and has to fulfil the Next Business Day (NBD) demand. Customer and SPC deliveries both have a leadtime of one business day and the cut-off time is at 17:00h (end of a period). If the EDC cannot fulfil the requested orders it first serves the customer on a first come first serve basis and then it serves the SPCs based on the “Fair Share” linear allocation rule. The Fair Share ratio is based on the demand of the specific item at each SPC. In the formula below,  $i$  and  $j$  are indices for one of the 1...N SPCs which have ordered the SKU  $k$  in the time period in which the shortage occurred.

Fair share ratio: 
$$q_i = \frac{\mu_{i,k}}{\sum_{j=1}^N \mu_{j,k}}$$

Where:

$q_i$  The fair share ratio of warehouse  $i \in W$

$\mu_{j,k}$  Demand rate of warehous  $j \in W$  for SKU  $k$

The Fair Share ratio of an SPC indicates which percentage of shortage the SPC gets allocated. Concluding, our Fair Share ratio allocates the shortage based on the percentage of the expected demand. The allocated shortages will be rounded up for the SPC which is closest to an integer, next the fair share ratio will be calculated again with the not allocated shortage and the SPC which did not get a shortage allocated yet. This sequence will be repeated till all shortage is allocated. For example, if SPC A orders 10 items and if the EDC has a shortage of 5 items due to orders of other SPCs and if SPC A's fair share ratio is 20%, 1 of the ordered items of SPC A will not be delivered the next business day.

Furthermore, capacity at the EDC is not restricted and we defined  $S_{0,k}$  as the basestock level of SKU  $k$  at the warehouse  $j$ . Demand at the EDC comes from customers or from SPCs, both demand streams have to be fulfilled the next business day. If the EDC orders products at the factory the leadtime is  $L_{EDC}$  and the inventory at the factory is infinite. As inventory costs we only calculate rent costs,  $r$ , for the inventory in the EDC.

#### **2.1.4 Order fulfilment process**

Customers place their order at a call centre that is operated by LNEP. The call centre knows the customers contract (service level) and location, and the actual inventory levels. Next, the call centre sends a request via a system message to a specific warehouse (SPC or EDC) to fulfil the demand. In Figure 2.6 a decision scheme is presented which is followed to determine from where to fulfil a customer's order. The call centre does know the inventory position of each warehouse, and allocates the demand to a warehouse which can fulfil the demand. The numbers before the warehouses (in Figure 2.6) indicate the sequence which the call centre uses to look for a warehouse which can fulfil the demand. If, for example, a premium customer places an order, normally the nearest SPC (sequence A) sends a dedicated courier to fulfil the demand within 2 or 4 hours (depending on the service contract). If the nearest SPC cannot deliver, a next nearest domestic SPC tries to fulfil the demand as soon as possible. If no near SPC is able to deliver that same day or quicker than the EDC, the premium customer will be served from the EDC with a NBD early in the morning day definite delivery. A day definite delivery is a premium delivery method which ensures that a parcel will be delivered the next business day. We use the term 'emergency shipment' for the order fulfilment of premium customer by the EDC and  $E^n$  is the parameter for the cost of an emergency shipment to country  $n$ .

If a NBD customer cannot be delivered from the EDC, a domestic SPC for which the stock versus expected demand relationship is the most favourable will try to deliver. This relationship is indicated by the chance that the demand in one period is bigger than the current inventory level. Furthermore, if both the EDC and SPCs cannot fulfil the customers demand LNEP tries

to find another solution which will be costly, the occurrence of this we call a 'lost sale' with cost  $LS_s$  for customer type  $s$ .

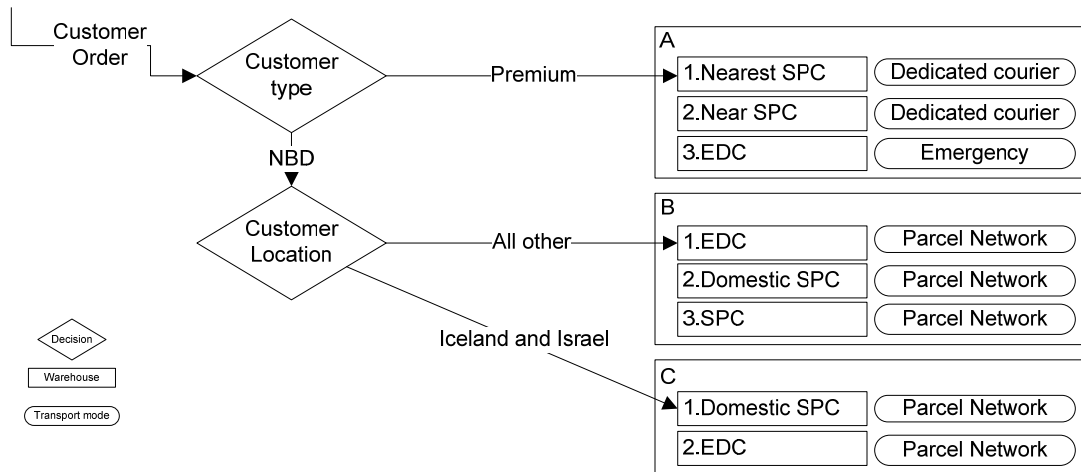

**Figure 2.6: Customer order allocation to warehouse and transport mode**

If a premium customer calls, the call centre has 15 minutes to create an order and send the order to a SPC. Next, 10 minutes are planned for processing at the SPC and 20 minutes for picking at the SPC. If a customer requires a 2 hour service level, the dedicated courier has 75 minutes to deliver. A dedicated courier has 195 minutes for delivering a SKU at the customer's site when 4 hour service level was required. The 2 and 4 hour time schedule for a premium delivery is presented in Figure 2.7. The required service performance for premium customers,  $Y_{Prem}$ , is the percentage of premium orders fulfilled on time. For NBD customers we use,  $Y_{NBD}$  as percentage of NBD orders fulfilled on time.

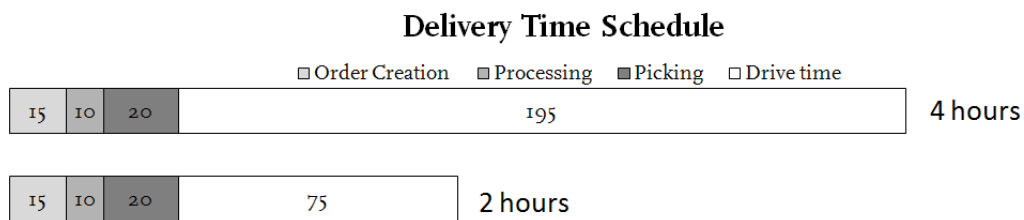

**Figure 2.7: Delivery Time Schedule for Premium deliveries**

The costs of the call centre are not taken into account and only the transportation costs are calculated. The cost parameters of a dedicated courier are presented in Table 2.5. The values of the transport cost vary per country (superscript  $n$ .) During office and out of office hours a fixed minimum amount is calculated for the first 30 kilometres and for each kilometre thereafter an additional amount is charged.

Cost Type	Cost	Explanation
Transportation Services	$T_{OH}^n$	Transport cost minimum charge per order within 30kms
Transportation Services	$t_{OH}^n$	Transport cost per additional KM driven (one way only)

**Table 2.5: Transport cost SPC-Customer**

The kilometres and drive time between a SPC and delivery location are 2-digit postal code based. We do not use the exact number of kilometres but we use the distance from the SPC to the main city, which has the same first two numbers in the postal code. For example a customer would be located in Geldrop (postal code 5660XX), we would use the distance from the SPC to Eindhoven (postal code 5600) which is the biggest city in the 2-digit postal code area. The distances are road based and will have an error due to the fact that the real start and end point are different. Additionally, the distances are only used for premium deliveries and will have an equal error effect on all scenarios and models.

### 2.1.5 SPC Replenishment

The SPCs follow a basestock inventory policy and we defined  $S_{j,k}$  as the basestock level of SKU  $k$  at the warehouse  $j$ . The transportation between the EDC and SPCs is done via a parcel network of a logistic service provider. LNEP has to pay the parcel tariffs of the logistic service providers for the shipments to the SPCs. The parameter  $PI_w^{n_1, n_2}$  is used to indicate the cost of sending an shipment of which the total weight falls in weight class  $w$  from country  $n_1$  to country  $n_2$ . Furthermore, we use,  $L_{i,j}$ , for shipments from EDC/SPC  $i$  to EDC/SPC  $j$ . We use the parameter,  $\gamma_{ALLOC}$ , for the percentage of SPC replenishment deliveries on time.

### 2.1.6 Parameters

In section 2.1.2 till 2.1.5 we have discussed the five parts of the network and have introduced parameters. In the current situation the SPC replenishment is done via the international parcel/express network. In the remainder of this section, we will give an overview of the introduced parameters.

#### Input Sets

$W$	Set of warehouses (SPCs, RDCs and EDC)
$S$	Set of customer types: $\{2h, 4h, NBD\}$
$K$	Set of SKUs
$C$	Set of customer locations
$N$	Set of countries
$G$	Set of weight classes

#### Input Warehouses

$t_j^n$	Binary variable, 1 if $j \in W$ is located in $n \in N$ otherwise 0
$s_j$	Binary variable, 1 if $j \in W$ is an SPC otherwise 0
$e_j$	Binary variable, 1 if $j \in W$ is an EDC otherwise 0
$S_{j,k}$	Base-stock level of SKU $k \in K$ at warehouse $j \in W$
$L_j$	Replenishment leadtime for warehouse $j \in W$
$L_{i,j}$	Leadtime for shipments between SPC $i \in W$ and SPC $j \in W$
$\mu_j$	Demand rate of warehouse $j \in W$ for SKU $k \in K$
$q_i$	Fair share ratio of warehouse $i \in W$

### Input Customers

$\lambda_{c,s,k}$	Demand rate of customer location $c \in C$ , for SKU $k \in K$ , customer type $s \in S$
$d_{j,c}$	Distance in kilometres from SPC $j \in W$ to customer location $c \in C$
$dt_{j,c}$	Drive time in hours from SPC $j$ to customer location $c$

### Input SKUs

$W_k$	Weight of item $k$ in kg
$Vol_k$	Volume of SKU $k$ in $m^3$
$V_k$	Value of item $k$ in euro's

### Input Cost Parameters

$PI_w^{n1,n2}$	Cost of sending a parcel which falls in weight class $w$ from country $n1 \in N$ to country $n2 \in N$
$E^n$	Cost of an emergency shipment from the EDC to a customer in country $n \in N$
$LS_s$	Cost of a lost sale of customer type $s \in S$
$I_O^{n,SPC}$	Inbound handling cost per part (new order)
$I_p^{n,SPC}$	Outbound handling cost per additional part thereafter in the same order
$O_O^{n,SPC}$	Outbound handling cost per part (new order)
$O_p^{n,SPC}$	Outbound handling cost per additional part thereafter in the same order
$r$	Monthly rent cost on inventory value
$T_{OH}^n$	Transport cost for a dedicated courier per order within 30kms (office hours)
$t_{OH}^n$	Transport cost for a dedicated courier per additional KM driven (office hours)
$T_{OOH}^n$	Transport cost for a dedicated courier per order within 30kms (OOH)
$t_{OOH}^n$	Transport cost for a dedicated courier per additional KM driven (OOH)

### Output Service levels

- $\gamma_{Prem}$  Service performance of premium customers, percentage of premium orders fulfilled on time
- $\gamma_{NBD}$  Service performance of premium customers, percentage of NBD orders fulfilled on time
- $\gamma_{ALLOC}$  Service performance of shipments within the network, percentage of internal orders fulfilled on time

## 2.2 Three-echelon network

The basic structure of the three-echelon network is presented in Figure 2.8, the upstream warehouse is the EDC which replenishes the RDCs. The most downstream warehouses, the SPCs, are replenished by their Regional Distribution Centre (RDC). The RDC also fulfils demand of customers which request the delivery on the next business day. The SPCs fulfil customer demand which have a requested leadtime of 2 or 4 hours. The models infrastructure consists of seven main components: Customers, Spare Parts Centres (SPCs), Regional Distribution Centres (RDCs), the European Distribution Centre (EDC), SPC Replenishment, RDC Replenishment and the order fulfilment process. In this order each of these seven components is discussed in a subsection.

The model has periods of one business day, each period starts at 08:00h and will end at 17:00h. If one period is finished the next period starts immediately afterwards (e.g. 17:00h of period x and 08:00h of period x+1 are the same.) A graphical representation of the time is given in Figure 2.5.

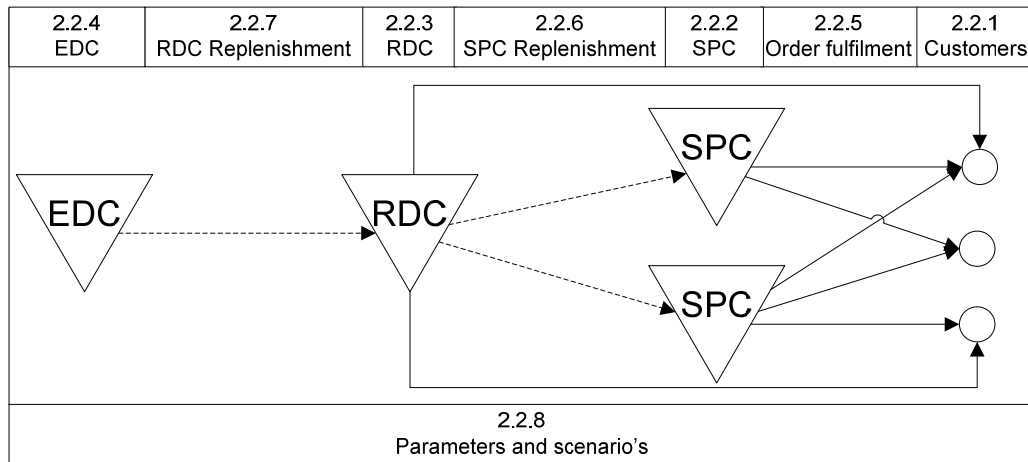

**Figure 2.8: Three-echelon basis structure**

### 2.2.1 Customers

The customers in the two- and three-echelon model are identical and have the same characteristics. A thorough description of the customers in our model can be found in

Subsection 2.1.1. In this subsection we only reintroduce the parameters for the demand rate, distance and drive time:

$\lambda_{c,s,k}$  Demand rate of customer location  $c \in C$ , customer type  $s \in S$ , for item  $k \in K$

$d_{j,c}$  Distance in kilometres from warehouse  $j \in W$  to customer location  $c \in C$

$dt_{j,c}$  Drive time in hours from warehouse  $j \in W$  to customer location  $c \in C$

### 2.2.2 SPCs

The network consists of a set of warehouses  $j \in W$  (SPCs, RDCs and EDC.) In Subsection 2.1.2 the SPC is introduced with the same characteristics as it has in the three-echelon model. The only difference lies in the replenishment of the SPC which, in the three-echelon network, is done by the RDC.

### 2.2.3 RDC

For each region or country one SPC will be transformed into an RDC, the specific locations will be discussed in the scenario and simulation chapter. The capacity of an RDC is not restricted. The RDCs are mainly used for fulfilling NBD demand and replenishment of the SPCs. We assume the same cost factors for a RDC as for a SPC, which can be found in Section 2.2.1.

A RDC will first fulfil the customer demand and if it cannot fulfil all the SPC demand in a specific period the inventory shortage will be allocated to each SPC based on the Fair Share ratio (see section 2.1.3 or 2.2.4.) The allocated shortage is communicated to the EDC and then the EDC tries to replenish the SPCs which have been allocated a shortage. Finally, we restate  $W$  as the set of warehouses (SPCs, RDCs and EDC.)

### 2.2.4 European Distribution Centre

There is one European Distribution Centre (EDC), which is located in Helmond (Sojadijk 4, 5704RL), the operations and warehousing at the EDC is done by Kuehne&Nagel. The EDC replenishes the RDCs with leadtime  $L_{i,j}$ . If the EDC cannot fulfil the requested orders it first serves customers then SPCs and then RDCs both with the “Fair Share” linear allocation rule. The Fair Share ratio is based on the demand of the specific item at each RDC. In the formula below are  $i$  and  $j$  indices for one of the 1...N RDCs which have ordered the item  $k$  in the time period of the shortage.

Fair share ratio: 
$$q_i = \frac{\mu_{i,k}}{\sum_{j=1}^N \mu_{j,k}}$$

Where:

$\mu_{j,k}$  Demand rate of SPC  $j$  for item  $k$

The Fair Share ratio of an SPC indicates which percentage of shortage the SPC will get allocated. Concluding, our Fair Share ratio allocates the shortage based on the percentage of the expected demand. For example, if RDC A orders 10 items and if the EDC has a shortage of 5 items due to orders of other RDCs and if RDC A's fair share ratio is 20%, 1 of the ordered items of RDC A will not be delivered the next business day.

Furthermore, capacity at the EDC is not restricted and we defined  $S_{j,k}$  as the basestock level of SKU  $k$  at the warehouse  $j$ . If the EDC orders products at the factory the leadtime is  $L_{EDC}$  and the inventory at the factory is infinite. As inventory costs we only calculate rent costs,  $r$ , for the inventory in the EDC.

### 2.2.5 Order fulfilment process

In Figure 2.9 a decision scheme is presented to determining from where a customer order should be fulfilled. The call centre does know the actual inventory position of each warehouse thus allocates the demand to a warehouse which can fulfil the demand. The numbers before the warehouses (in Figure 2.9) indicate the sequence which the call centre uses to look for a warehouse which can fulfil the demand. If, for example, a premium customer places an order, normally the nearest SPC (sequence A) will send a dedicated courier to fulfil the demand within 2 or 4 hours (depends on service contract), if the nearest SPC cannot deliver a next nearest domestic SPC tries to fulfil the demand as soon as possible. If, no near SPC is able to deliver that same day or quicker than the RDC, the premium customer will be served from the RDC with a same day or NBD early in the morning day definite delivery. A day definite delivery is a more expensive delivery method which ensures that a SKU will be delivered the next business day. If, a premium customer cannot be served within the region (SPCs or RDC) an emergency shipment from the EDC will follow. We use the term 'emergency shipment' for the order fulfilment of premium customer by the EDC and  $E^n$  is the parameter for the cost of an emergency shipment to country  $n$ . If the EDC, RDC and SPCs cannot fulfil the customers demand LNEP tries to find another solution which will be costly, the occurrence of this we call a 'lost sale' with cost  $LS_s$  for service level  $s$ .



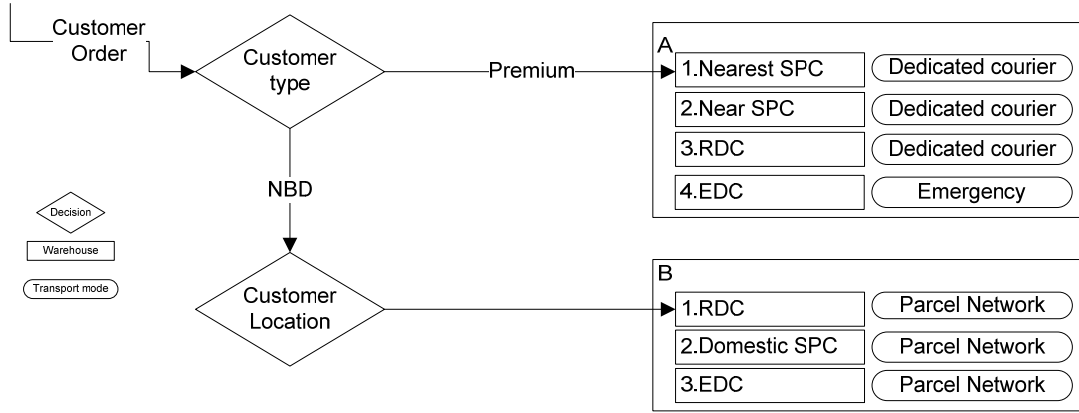

Figure 2.9: Customer order allocation to warehouse and transport mode

The order fulfilment time schedule, drive time restrictions and service performance measurement are in the three-echelon model equal to the ones in the two-echelon network and can be found in Subsection 2.1.4. Furthermore, the delivery costs are also equal and presented in Table 2.5 in Subsection 2.1.4.

### 2.2.6 SPC Replenishment

The SPCs follow a basestock inventory policy and we defined  $S_{j,k}$  as the basestock level of SKU  $k$  at the SPC  $j$ . The parameter  $PI_w^{n_1,n_2}$  is used to indicate the cost of sending an shipment of which the total weight falls in weight class  $w$  from country  $n_1$  to country  $n_2$ . Furthermore, we use,  $L_{i,j}$ , for shipments from RDC  $i$  to RDC  $j$ . We use the parameter,  $\gamma_{ALLOC}$ , for the desired percentage of SPC replenishment deliveries on time.

### 2.2.7 RDC Replenishment

Like SPC replenishment, the RDCs follow a basestock inventory policy and we defined  $S_{j,k}$  as the basestock level of SKU  $k$  at the RDC  $j$ . The parameter  $PI_w^{n_1,n_2}$  is used to indicate the cost of sending an shipment of which the total weight falls in weight class  $w$  from country  $n_1$  to country  $n_2$ . Furthermore, we use,  $L_{i,j}$ , for shipments from EDC  $i$  to RDC  $j$ . We use the parameter,  $\gamma_{ALLOC}$ , for the percentage of SPC replenishment deliveries on time.

### 3. Method

In Chapter 2 models for analyzing a two- and three-echelon are introduced. In this chapter we present the method to answer the research questions with the models earlier presented. In the first subsection we discuss the scenarios which need to be evaluated to answer the research questions. The input parameters of the models are based on TLP and LNEP information. However, assumptions have to be made about the demand distribution and the determination of the basestock levels determination. In Section 3.2 we analyze the demand which occurred in the calendar year 2009. Due to the fact that LNEP's basestock level determination method is confidential, we have to use a method to determine the basestock levels for our model. This will be discussed in Section 3.3.

#### 3.1 Scenarios

Basically we have two situations: a two- and a three-echelon network design. In the two-echelon situation we have an EDC in the Netherlands and 145 fixed location SPCs. Together with TLP and LNEP we have identified four regions, for the first three regions an RDC could be interesting:

1. UK (Great Britain, Northern Ireland and Ireland)
2. Iberia (Spain and Portugal)
3. Nordics (Denmark, Sweden, Norway and Finland)
4. Other (Netherlands, Belgium, Luxemburg, Germany, Austria, Swiss, Iceland, France, Italy, Greece, Malta, Cyprus and Israel)

If we compare a two- and a three-echelon network design we can expect some differences in cost. In a three-echelon network a SKU which is used for SPC replenishment or NBD customer order fulfilment is shipped with the standard/road network to the RDC and from there via the domestic parcel network. Shipments to the RDC are consolidated and we expect to see that the costs for standard/road network shipments plus the domestic parcel shipment are less than the one-by-one sending with the international parcel network which is done in a two-echelon network. Furthermore, we expect inventory holding and handling costs to increase with the increase in number of echelons. In a three-echelon network we expect that emergency shipments can sometimes be delivered from the RDC which will be less expensive than an emergency shipment from the EDC. Concluding, we expect inventory holding cost and handling costs to increase and the following cost factors to decrease if we change from a two- to a three-echelon network:

- Replenishment and NBD transport cost;
- Emergency shipment costs;

### 3.1.2 Emergency shipment based location model

In each of the first three regions (UK, Iberia and Noridcs) we have to decide which SPC will be transformed into an RDC. Not all parts of the regions are reachable within two business days from the EDC with the TLP standard/road network. We use a 2 business days leadtime as maximum for the RDC selection. Furthermore, all relevant RDC cost are region based so this would have no influence on the locations decision. The only factors which does have influence on the *optimal* RDC location would be the costs of emergency and (lateral) premium deliveries. The cost of premium and emergency deliveries are distance based. RDC stock can be used for fulfilling premium customer demand and can be seen as an extra lateral transshipment possibility. To decide where to place the RDC we first only take the emergency shipments into account and use the model presented below.

$r \in R$  Set of TLP regions

$\lambda_{c,s,k}$  Demand rate of customer location  $c \in C$ , for SKU  $k \in K$ , customer type  $s \in S$

$d_{j,c}$  Distance in kilometres from SPC  $j \in W$  to customer location  $c \in C$

$l_{o,j}$  Leadtime for standard/road shipments from the EDC to SPC  $j \in W$

$t_j^r$  Binary parameter, 1 if  $j \in W$  is located in  $r \in R$  otherwise 0

$s_c^r$  Binary parameter, 1 if  $c \in C$  is located in  $r \in R$  otherwise 0

$RDC_j^r$  Binary decision variable, 1 if  $j \in W$  is the RDC of region  $r \in R$  otherwise 0

$$\min \sum_{c \in C, j \in W, k \in K, r \in R} (\lambda_{c,2 \text{ hour},k} + \lambda_{c,4 \text{ hour},k}) s_c^r d_{j,c} t_j^r RDC_j^r$$

$$\text{s.t.} \quad \sum_{j \in W} t_j^r RDC_j^r = 1 \quad \forall r \in R$$

$$l_j RDC_j^r \leq 2 \text{ (business days)} \quad \forall r \in R, \forall j \in W$$

$$RDC_j^r \in \{0,1\}$$

### 3.1.2 Emergency and lateral transshipment based location model

In addition to the model presented in the previous subsection we will now present an approximation model which does take both emergency and extra lateral transshipment possibility gains into account. We expect 2,5% of the orders to be not fulfilled on time and for simplicity we assume that these orders will be fulfilled with an emergency shipment from the RDC with a courier. Additionally, we assume that each SPC will fulfill 97% of its demand. Due to the possibility of lateral transshipments the overall performance for premium deliveries will become above 97%. Furthermore, we calculate the relative cost of premium non emergency deliveries with the distance and possibility that a certain SPC or RDC will fulfill the customers demand. We use  $\gamma_j$  for the delivery performance of warehouse  $j$ , and by this change we will

charge the distance from  $j$  to customer  $c$  as relative costs ( $d_{j,c}$ .) If the nearest warehouse is not able to deliver the next nearest warehouse will try to deliver, this warehouse can be found in the array of warehouses that can reach customer  $c$  within the time constraint on the second position ( $v_c(2)$ .) Consequently, the probability that this second warehouse will deliver the demand of customer  $c$  is given with  $(1 - \gamma_{v_c(1)})^1 \gamma_{v_c(2)}$ . If there is an RDC located at warehouse  $j$  the probability of delivering from warehouse  $j$  increase and we assume that the RDC will have the same service performance as the SPC. Furthermore, if we use binary variable  $RDC_j^r$  to indicate that the RDC is located at warehouse  $j$ . This will change the probability that the second warehouse in the array will deliver the demand of customer  $c$  into:  $(1 - \gamma_{v_c(1)})^{1+RDC_{v_c(1)}^r} \gamma_{v_c(2)}$ . To illustrate an example: we have three SPCs 1,2 and 3 and we place the RDC next to SPC 2 and we have one customer which is closest to SPC 1 then 2 then 3. The probability that the customer will be served from SPC 1 is given with  $\gamma_1$ , and the part of the demand that SPC 2 will deliver to the customer is given with  $(1 - \gamma_1)\gamma_2$  next the customer will look at the RDC and the RDC will service the following percentage of the customers demand  $(1 - \gamma_1)(1 - \gamma_2)\gamma_2$ . Finally, the third SPC will deliver another portion of the customer demand:  $(1 - \gamma_1)(1 - \gamma_2)^2\gamma_3$ . If we multiply each of these proportions with the distance from the specific SPC to the customer we get the relative costs of such a shipment. To generate the presented sequence we use:  $(\sum_{x=0}^{p_c} (\prod_{y=0}^x (1 - \gamma_{v_{c,2h}(y)})^{1+RDC_{v_{c,2h}(y)}^r}) \gamma_{v_{c,2h}(x+1)} (1 + RDC_{v_{c,2h}(x+1)}^r (1 - \gamma_{v_{c,2h}(x+1)}))$ . The complete model to find the *optimal* RDC location we used is presented below. The first part of the minimization function represents the relative emergency shipment costs and the second part represents the cost for 2 hour premium deliveries and the last part represents the cost for 4 hour premium deliveries.

- $v_{c,s}$  Array of warehouses that can reach customer  $c$  within the time constraint of customer type  $s \in S$   
 $p_c$  Length of array  $v_c$  of customer  $c$   
 $\gamma_j$  Delivery performance of warehouse  $j \in W$  ( $\gamma_0 = 0$ )

$$\begin{aligned} \min \quad & 0,025 * \sum_{c \in C, j \in W, k \in K, r \in R} (\lambda_{c,2 \text{ hour},k} + \lambda_{c,4 \text{ hour},k}) s_c^r d_{j,c} t_j^r RDC_j^r \\ & + \sum_{c \in C, k \in K, r \in R} \lambda_{c,2h,k} \left( \sum_{x=0}^{p_c} \left( \prod_{y=0}^x (1 - \gamma_{v_{c,2h}(y)})^{1+RDC_{v_{c,2h}(y)}^r} \right) \gamma_{v_{c,2h}(x+1)} (1 + RDC_{v_{c,2h}(x+1)}^r (1 - \gamma_{v_{c,2h}(x+1)})) \right. \\ & \left. - \gamma_{(v_{c,2h}(x+1))} s_c^r d_{v_{c,2h}(x+1),c} t_{v_{c,2h}(x+1)}^r \right) \\ & + \sum_{c \in C, k \in K, r \in R} \lambda_{c,4h,k} \left( \sum_{x=0}^{p_c} \left( \prod_{y=0}^x (1 - \gamma_{v_{c,4h}(y)})^{1+RDC_{v_{c,4h}(y)}^r} \right) \gamma_{v_{c,4h}(x+1)} (1 + RDC_{v_{c,4h}(x+1)}^r (1 - \gamma_{v_{c,4h}(x+1)})) \right. \\ & \left. - \gamma_{(v_{c,4h}(x+1))} s_c^r d_{v_{c,4h}(x+1),c} t_{v_{c,4h}(x+1)}^r \right) \end{aligned}$$

$$\text{s.t.} \quad \sum_{j \in W} t_j^r RDC_j^r = 1 \quad \forall r \in R$$

$$l_j RDC_j^r \leq 2 \text{ (business days)} \quad \forall r \in R, \forall j \in W$$

$$RDC_j^r \in \{0,1\}$$

### 3.1.3 Results location models

The maximum of possible RDC locations was 8 and we found the optimal solution of the models by using full enumeration for each region. The outcome of both models was the same and as RDC locations we found Birmingham, Skärholmen (near Stockholm) and Zaragoza. Consequently, the SPCs in Birmingham, Skärholmen and Zaragoza will be extended for the model as an RDC. The SPC and the RDC do have the same location but do not the same inventory, the RDC inventory can be used for premium customers but the SPC inventory will not be used for replenishment deliveries if the RDC is out of stock. The NBD customers in the UK, Nordics and Iberia will be served by the RDC in its region and NBD customers in the “other” region will be served by the EDC. Furthermore, the SPCs are replenished by the RDC in the region or the EDC. The second scenario will be simulated with the 3-echelon model, the NBD customers in the region “other” will be assigned to an RDC with zero basestock levels which leads (based on the sequence, see Figure 2.9) to the fact that these customers are served from the EDC.

## 3.2 Demand distribution

In the model we use  $\lambda_{c,s,k}$  as the demand rate of customers in location  $c \in C$  for SKU  $k \in K$ , and customer type  $s \in S$ . In most spare parts literature Poisson distributed demand rates are assumed, we also assume a Poisson demand rate and tested this assumption with the Kolmogorov-Smirnov Test. The Kolmogorov-Smirnov test indicates if an assumed distribution can be rejected with 95% confidence. For the premium customers none of the customer-service level-SKU combinations failed the Kolmogorov-Smirnov test and thus the assumption about Poisson distributed demand could not be rejected. For the NBD demand we found that for more than 90% of the combinations we could not reject that the demand occurred in 2009 followed a Poisson distributed demand rate. After an analysis of the reject demand rates we could not find symptoms which indicate that a Poisson demand rate would be completely wrong (e.g. non failure periods after replacement or batch ordering.) Furthermore, we could not find a distribution with a better non-rejection score. Consequently, for our project we assume Poisson distributed demand rates.

## 3.3 Inventory

As described earlier, due to the fact that LNEP’s basestock level determination method is confidential, we have to use a method to determine the basestock levels for our model. Because

of the Poisson distributed demand, delivery time requirements and lateral transshipments we decided to use the inventory planning model of Reijnen et al. (2009).

Motivated by a real life case Reijnen et al. (2009) developed an inventory model for spare parts with delivery time requirements and shipments from other than the closest warehouse (lateral transshipment) were taken into account. A network with multiple local warehouses and a central warehouse with idle stock is considered, the number and the places of the warehouses are input for the model and thus not incorporated in the optimization. Lateral transshipment is only allowed if the shipment can reach the customer within the pre-specified time limit and the modeled cost are: the (lateral) transshipment, emergency shipment and inventory holding cost. The replenishment lead times are assumed to be i.i.d. and the distribution is assumed to be exponential and will not incorporate cost. For the presented structure and costs Reijnen et al. (2009) developed an approximate evaluation algorithm and a greedy algorithm which can be used to set base stock inventory levels at the local warehouses. The algorithm is based on two approximation steps: (i) overflow demand streams are assumed to be Poisson distributed, and (ii) stock levels at the warehouses are assumed to be independent of each other. The performance of the algorithm does not deteriorate with the number of warehouses. The concluding results of taking lateral transshipment into account indicate significant cost reductions for expensive spare parts.

The model of Reijnen et al. (2009) is single-echelon and single-item. We have more than 7.000 SKUs and of course a multi-item approach would be preferable. Reijnen et al. (2009) do suggest a method to modify the model to multi-item. Unfortunately, 7.335 SKUs and 145 SPCs create too many instances and too big matrices which makes our case undoable with the suggested procedure. Furthermore, if we would model each customer separately the procedure would become very time consuming thus we modeled the expected demand rate at each SPC of each service level as a customer of the original model. Consequently, we have created 294 (2 x 145 SPCs + 1 EDC + 3 RDCs) ‘customers.’ The method for modeling customers will have no influence on the total initial demand stream at each SPC. Additionally, it will have influence on the lateral demand streams which arrive at a SPC because in our case all customers are located at a SPC which does have influence on the (in)possibility of lateral transshipments. Next, we will present the approximation method of Reijnen et al. (2009) before we will discuss the specific parameter settings.

#### **Approximation method of Reijnen et al. (2009)**

$W$	Set of warehouses (SPCs, RDCs and EDC)
$S$	Set of customer types: $\{2h, 4h, NBD\}$
$K$	Set of SKUs
$C$	Set of customers

$N$	Set of countries
$S_{j,k}$	Base-stock level of SKU $k \in K$ at warehouse $j \in W$
$L_j$	Replenishment leadtime for warehouse $j \in W$
$\lambda_{c,s,k}$	Demand rate of customer location $c \in C$ , for SKU $k \in K$ , customer type $s \in S$
$\mu_{c,k}$	Demand rate of customer $c \in C$ for SKU $k \in K$
$t_j^n$	Binary variable, 1 if $j \in W$ is located in $n \in N$ otherwise 0
$dt_{j,c}$	Drive time in hours from SPC $j$ to customer location $c$
$d_{j,c}$	Distance in kilometres from SPC $j \in W$ to customer location $c \in C$
$V_k$	Value of item $k$
$r$	Monthly rent cost on inventory value (15%)
$T^n$	Transport cost for a dedicated courier per order within 30kms
$t^n$	Transport cost for a dedicated courier per additional KM driven (office hours)
$\gamma_s$	Service performance of customer type $s \in S$ , percentage of premium orders fulfilled on time
$p_c$	Length of array $v_c$
$v_c$	Array of warehouses that can reach customer $c$ within the time constraint
$\alpha_{c,j}$	The fraction of demand customer $c$ that is fulfilled by warehouse $j$
$\alpha_c$	Fraction of demand of customer $c$ that is fulfilled by the regional warehouses
$\theta_c$	Fraction of demand of customer $c$ that is satisfied by an emergency shipment
$c_{c,j}$	$:= \sum_{n \in N} t_j^n (T^n + t^n d_{j,c})$ Cost of incurred to transport an SKU from warehouse $j$ to customer $c$
$c_{c,0}$	Cost of an emergency shipment to customer $c$
$\beta_j$	Fraction of the total demand rate that warehouse $j$ can deliver from stock

$$\gamma(S) = \frac{\sum_{c \in C} \mu_c \alpha_c}{\sum_{c \in C} \mu_c} \quad \text{Fraction of demand that is delivered within the time limit}$$

$$L(x, y) = \frac{y^x / x!}{\sum_{z=0}^{\infty} y^z / z!} \quad \text{Erlang loss probability}$$

$$C(S) = \sum_{j \in W} S_j V_k r + \sum_{c \in C} (\mu_c \theta_c c_{c,0} + \sum_{j \in W} \mu_c \alpha_{c,j} c_{c,j}) \quad \text{Total cost per time unit}$$

$$R(\mathbf{S}, j) = \frac{\gamma(\mathbf{S} + e_j) - \gamma(\mathbf{S})}{\Delta C(\mathbf{S}, j)} \quad \text{Biggest bang for the buck ration with } e_j \text{ as the added number of items to the basestock levels } \mathbf{S}$$

For the first step of the algorithm we assume that the fill rates of the warehouses are known, and we estimate the total demand a warehouse faces. We note that the demand at warehouse  $j$  from customer  $c$  includes requests for lateral transshipments. The same request might go to multiple warehouses until one has stock on hand, so in general  $\sum_{j \in W} M_{c,j} \geq \mu_c$ . For warehouse  $j = v_c(1)$  the total demand warehouse  $j$  faces from customer  $c$ ,  $M_{c,j}$ , is precisely the total demand customer  $c$  generates:  $M_{c,j} = \mu_c$ . Suppose we know the fill rates  $\beta_j$ ,  $j \in W$  of the warehouses. If we assume that the stock levels at the local warehouses are independent, then we know that the demand rate warehouse  $\hat{j} = v_c(2)$  faces from customer  $c$  is on average  $(1 - \beta_j)M_{c,j}$ .

If we assume that the demand warehouse  $j$  faces from customer  $c$  is a Poisson process with rate  $M_{c,j}$ , then the total demand warehouse  $j$  faces is a Poisson process with rate  $M_j$ . This assumption does not hold in general, but is reasonable for high fill rates. This follows from the observation that the probability of having more than 1 demand during a stock-out period is rather small. For the second step of the algorithm we assume that the demand at a warehouse is known and estimate the fill rates. To determine the fill rates of the warehouses we can use known results from the Erlang loss system.

We use an iterative procedure to determine  $M_j$ ,  $M_{c,j}$ , and  $\beta_j(S)$  from which we derive  $\alpha_{c,j}(S)$  and  $\theta_c(S)$ . Initially, we assume that no lateral transshipments take place, therefore we can set  $M_{c,v_c(1)} = \mu_{c\cdot}$ , and  $M_{c,v_c(i)} = 0$  for  $2 \leq i \leq |v_c|$ . From these values we can determine  $M_j = \sum_{c \in C} M_{c,j}$  and  $\beta_j(S) = 1 - L(S_j, t_j^{reg} M_j)$ . Given the fill rates  $\beta_j(S_j)$  for the warehouses, we can obtain a better estimate for the demand flows  $\hat{M}_{c,j}$ . We iterate until  $M_j$  does not change more than  $\epsilon$ , with  $\epsilon$  small. After the iterative procedure, we determine from the demand flows  $M_{c,j}$  the values for  $\alpha_{c,j}(S)$  and  $\theta_c(S)$  as last steps of the initialization.

Next, the greedy algorithm consists of three phases, an initialization phase, a costs phase, and a time-based fill rate phase. In the initialization phase all inventory levels  $S_j, j \in J$  are set to 0. In the costs phase, the greedy algorithm places inventory one by one such that the system costs are minimized each time an extra item is put on stock. It will continuously place an extra unit of inventory until no cost reduction can be achieved in this way. This is done by determining the costs difference for each warehouse when an extra unit of stock is placed. Therefore we define  $\Delta C(S, j) = C(S + ej) - C(S)$ . In case the resulting stock levels are such that the  $\gamma(S) \geq \gamma_0$ , then the algorithm terminates. Otherwise we continue with the last phase. In this phase the greedy algorithm continues with placing stock at the warehouses where the biggest improvement in service level is achieved compared to the extra total costs. Therefore we define the ratio  $R(S, j) = \frac{\gamma(S+ej) - \gamma(S)}{\Delta C(S, j)}$ . As long as  $\gamma(S) < \gamma_0$ , we have not yet met the time-based fill rate constraint and we will place an extra unit of stock at the warehouse with the highest ratio  $R(S, j)$ . (Reijnen et al., 2009)



**Procedure:**

For each  $k \in K$

**Initialization**

$$\forall j \in W^*, \gamma_j := 1 - L(S_{j,k}, L_j, \sum_{c \in C | v_c(1)=j} \mu_{c,k})$$

$$\forall c \in C, M_{c,v_c(1)} := \lambda_{c,s,k}$$

$$\forall c \in C, j \neq v_c(1) \in W, M_{c,j} := 0$$

Repeat while  $M_{c,j}$  does not change more than  $\varepsilon$  for each  $j \in W^*$

$$\text{Step 1 } \forall c \in C \text{ and for } 2 \leq i \leq p_n: M_{c,v_c(i)} := (1 - \beta_{v_c(i-1)})M_{c,v_c(i-1)}$$

$$\text{Step 2 } \forall j \in W^*, M_j := \sum_{c \in C} M_{c,j}, \beta_j := 1 - L(S_{j,k}, L_j M_j,)$$

End Repeat

**Finalization**

$$\forall c \in C \text{ and } \forall j \in W^*, \alpha_{n,j}(S) := \frac{\beta_j(S)M_{n,j}}{\mu_n}$$

$$\forall c \in C, \theta_n := 1 - \sum_{i=1}^{p_n} \alpha_{n,v_c(i)}$$

End Initialization

**Greedy Algorithm**

**Initialization**

$$\text{Set } S_{j,k} := 0, j \in W^*$$

$$\text{Calculate } \Delta C(\mathbf{S}, j), j \in W^*$$

Repeat while  $\min \{\Delta(\mathbf{S}, j)\} \leq 0$ :

1. Find  $\hat{j} = \operatorname{argmin}_{j \in W^*} \{\Delta C(\mathbf{S}, j)\}$

2. Set  $S_{\hat{j},k} := S_{\hat{j},k} + 1$ ;

3. Calculate  $\Delta C(\mathbf{S}, j), j \in W^*$

End Repeat while

$$\text{Calculate } R(\mathbf{S}, j), j \in W^*$$

Repeat while  $\gamma(\mathbf{S}) < \gamma_0$ :

1. Find  $\hat{j} = \operatorname{argmax}_{j \in W^*} \{\Delta C(\mathbf{S}, j)\}$

2. Set  $S_{\hat{j},k} := S_{\hat{j},k} + 1$ ;

3. Calculate  $R(\mathbf{S}, j), j \in W^*$

End Repeat while

End Greedy Algorithm

End for

The costs of an emergency shipment are difficult to determine and due to the lack of data on this issue we could not make a reasonable assumption about these costs. Consequently, we had to have set the value of an emergency shipment to zero in the procedure, due to which no inventory will be added (repeat while loop number three.)

The described model is single-echelon and we have two multi-echelon cases. We will model the replenishment and NBD demand as one single demand stream. Consequently, we can run the procedure with the RDCs or EDC as warehouse with no lateral transshipment possibilities and summed demand stream of NBD and replenishment. Although, we have to notice that requiring the same service level for replenishment and customer delivery could be not optimal. However, for the two-echelon scenario we expect this to have minor influence because it will only have influence on the EDC basestock levels and more than 85% of the EDC demand comes from NBD customers and can be seen as a single-echelon model. The results of the use of the inventory model in combination with the simulation model will be discussed in the next chapter.

It has to be noticed that the evaluation algorithm seems to overestimate the service level performance (Reijnen et al., 2009). In our case we have approximately constant replenishment leadtimes and the model of Reijnen et al. (2009) uses exponential leadtimes. Based on a sensitivity analysis conducted by Reijnen et al. (2009) we state that the model is rather insensitive to the choice of exponential or deterministic leadtimes especially under higher service targets.

## 4. Results

This chapter presents the results of the scenarios presented in the previous chapter. First, the initial design of the experiment and the results of this experiment are discussed. Next, we discuss modifications on the basic scenarios and the results of the modifications. Finally, a conclusion is drawn.

### 4.1 Design of experiment

This section first describes the design approaches that are included in the design of the experiment. Next, the scenario set that is used to address the design question, is presented.

We have two basic scenarios: a two- and three-echelon case which we give the scenario ids 2-0, 2-1 and 3-1. The differences between the scenarios are schematically presented. In scenario 2-1 all regions have the same network design and policies. Furthermore, the SPC is replenished by the EDC via the parcel express transport mode and we use the earlier described 2-echelon model to analyze the performance. Moreover, the basestock levels of scenario 2-1 and 3-1 are determined via the modified procedure of Reijnen et al. (2009) which is described in Section 3.3. Scenario 2-0 is the zero scenario which we use to validate the outcome of the model and inventory levels. In scenario 2-0 we use inventory levels which were used in December 2009. In scenario 3-1 three regions (UK, Iberia and the Nordics) have a RDC which is replenished by the EDC via the standard road network. The RDCs are located in Birmingham, Zaragoza and Skärhomen and all have a leadtime of 2 business days via the standard/road network. We simulate the complete supply chain as a whole and we modeled a fake RDC for the region “Other” with no stock due to which NBD demand of the region “Other” will be fulfilled by the EDC.

Scenario	Region	Ware-houses	Replenishment mode (leadtime)	Model	Basestock planning
2-0	All	SPC EDC	Express (1 business day)	2-echelon	Given levels Given levels
2-1	All	SPC EDC	Express (1 business day)	2-echelon	Modified Reijnen et al. (2009) Modified Reijnen et al. (2009)
3-1	UK, Iberia and Nordics	SPC RDC EDC	Express (1 business day) Standard (2 business days)	3-echelon	Modified Reijnen et al. (2009) Modified Reijnen et al. (2009) Modified Reijnen et al. (2009)
	Other	SPC RDC EDC	Express (1 business day)		Modified Reijnen et al. (2009) Zero stock for all SKUs Modified Reijnen et al. (2009)

**Table 4.1: Basic scenarios**

As performance of a network we will measure the on time deliveries per service level per region. As costs we have defined four types: courier, handling, inventory and transport. In Table 4.2 an overview of the four cost types is presented with the related cost parameters of the model, more information about the parameters can be found in Chapter 2.

Cost Type	Related cost parameters	
Courier	$T_{OH}^n$	Fixed cost for courier deliveries for first 30 km
	$t_{OH}^n$	Variable Cost for courier deliveries for each kilometer after 30 km
Handling	$I_O^{n,SPC}$	Inbound handling cost per part (new order)
	$I_p^{n,SPC}$	Inbound handling cost per additional part in an order
	$O_O^{n,SPC}$	Outbound handling cost per part (new order)
	$O_p^{n,SPC}$	Outbound handling cost per additional part in an order
Inventory	$r$	Rent percentage for holding inventory
	$V_k$	Value of item $k$ in euro's
Transport	$PI_w^{n1,n2}$	Cost for sending replenishment and NBD shipments

**Table 4.2: Cost parameters per type**

## 4.2 Initial design results

Scenario 2-1 has for most SKUs less inventory than scenario 2-0. Furthermore, the service performance of scenario 2-0 is below the service level of scenario 2-1, this can be explained by the fact that LNEP in December 2009 for example did know that for some SKUs no demand would occur in the future. Consequently, no stock for these SKUs was held in scenario 2-0. Furthermore, we conclude that the inventory determination policy of Reijnen et al. (2009) leads to comparable basestock levels. For our research questions an in depth analysis of scenario 2-0 is not required and is not presented in this report. Scenario 2-0 will not be used as benchmark for the cost and performance, we only used scenario 2-0 as benchmark for the basestock levels.

The performance of both scenarios in terms of costs and service performance are presented in Table 4.3 and graphically presented in Figure 4.1. The inventory holding costs at the EDC are accumulated by the inventory holding cost of the region "other." It should be noticed that in this public report most of the cost data is transformed to normalized values, which are of equal value for comparisons but hide sensitive business values.

	Costs					Service levels			
	Total	Courier	Handling	Inventory	Transport	Overall	2 Hour	4 Hour	NBD
<b>Scenario 2-1</b>									
UK	3,40	0,06	0,32	0,48	2,53	97,36%	100,00%	97,14%	97,37%
Iberia	7,80	1,43	0,34	3,67	2,36	97,60%	97,73%	99,94%	97,13%
Nordic	4,51	0,48	0,27	1,07	2,69	97,30%	100,00%	98,48%	97,37%
Other	84,30	8,65	1,83	63,02	10,83	99,04%	98,19%	99,66%	99,12%
<b>Total</b>	<b>100,00</b>	<b>10,60</b>	<b>2,76</b>	<b>68,24</b>	<b>18,41</b>	<b>98,50%</b>	<b>98,22%</b>	<b>99,65%</b>	<b>98,34%</b>

	Total	Courier	Handling	Inventory	Transport	Overall	2 Hour	4 Hour	NBD
<b>Scenario 3-1</b>									
UK	14,10	0,06	0,46	13,45	0,12	99,29%	100,00%	97,14%	99,39%
Iberia	17,73	1,43	0,52	14,09	1,69	99,18%	97,73%	99,94%	99,22%
Nordic	14,96	0,48	1,09	10,60	2,79	99,79%	100,00%	98,48%	99,30%
Other	84,33	8,65	1,83	63,02	10,83	99,90%	98,19%	99,66%	99,61%
<b>Total</b>	<b>131,12</b>	<b>10,63</b>	<b>3,90</b>	<b>101,16</b>	<b>15,43</b>	<b>99,69%</b>	<b>98,22%</b>	<b>99,65%</b>	<b>99,86%</b>

	Relative Difference					Absolute Difference			
	Total	Courier	Handling	Inventory	Transport	Overall	2 Hour	4 Hour	NBD
<b>Comparison</b>									
UK	315%	0%	43%	2702%	-95%	1,94%	0,00%	0,00%	2,02%
Iberia	127%	0%	50%	284%	-28%	1,59%	0,00%	0,00%	2,09%
Nordic	232%	0%	313%	893%	4%	2,49%	0,00%	0,00%	1,93%
Other	0%	0%	0%	0%	0%	0,86%	0,00%	0,00%	0,49%
<b>Total</b>	<b>31%</b>	<b>0%</b>	<b>41%</b>	<b>48%</b>	<b>-16%</b>	<b>1,19%</b>	<b>0,00%</b>	<b>0,00%</b>	<b>1,52%</b>

Table 4.3: Scenario performance

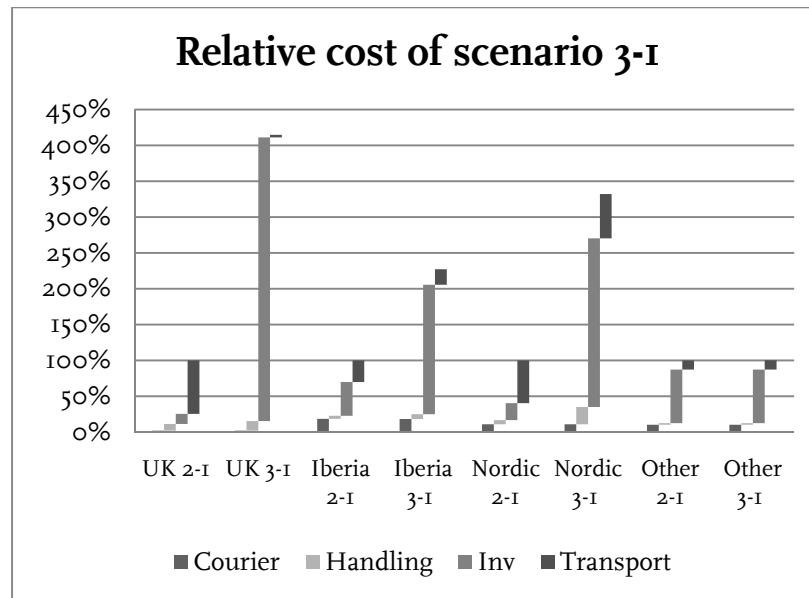
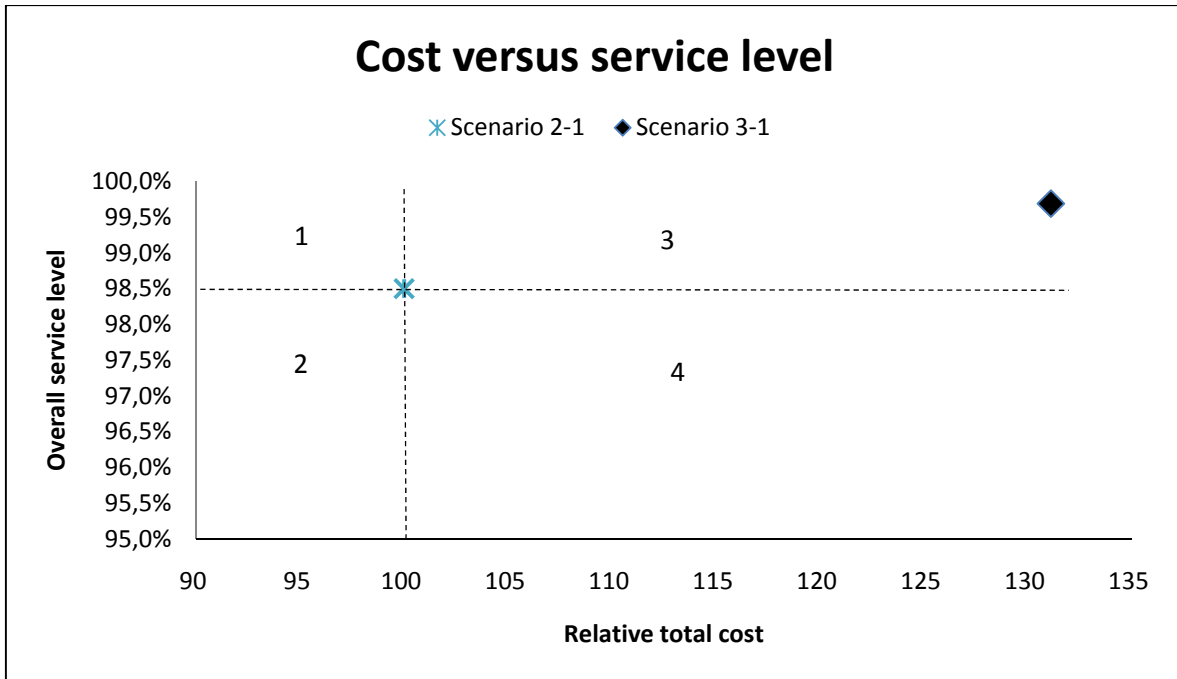

Figure 4.1: Relative cost of scenario 3-1 compared to base scenario 2-1

From the cost data it can be concluded that the three-echelon scenario has 31% higher costs. The change from a two- to the described three-echelon network would decrease the transportation cost (NBD express deliveries and replenishment deliveries) due to the fact that the costs of standard/road shipments to the RDCs plus the RDCs to NBD customer deliveries via the domestic parcel network are less than the international parcel shipment costs to NBD customers. However, increasing the number of echelons will increase the handling costs with 41%. Furthermore, an extra echelon requires extra inventory. The modified procedure of Reijnen et al. (2009) indicates that the total inventory value has to increase with 48% to achieve the desired service levels. From the results, it can be concluded that in the UK the increase of inventory in the region increases the most due to an RDC and the transportation costs decrease the most. Due to the RDCs the total inventory increased and because we assume same service requirements for replenishment orders as for NBD customers the inventory at the EDC will stay the same. Service performances for NBD customers does increase due to the use of RDC in all regions. This can be explained by the fact that more inventory is held for NBD customers and NBD customers in region “other” will in case of shortage be served before RDC replenishment.

In Figure 4.12 we have presented the service level performance of both scenarios. The three-echelon scenario does perform better in terms of on time deliveries. More specific, an increase of the NBD on time deliveries with around 2 percent point in the regions with an RDC. If we combine the cost and service performance of both scenarios we get the scatter plot presented in Figure 4.2 we see four blocks which indicate an improvement in terms of costs and the allowed decrease in service level.



**Figure 4.2: Cost and service level performance scenario 2-1 and 3-1**

From Figure 4.2, it can be concluded that the current three-echelon scenario performs too good in terms of service performance and that it is likely to expect that decreasing the inventory will lead to a scenario which will be in one of the four squares. Each of the four squares is better in terms of costs compared to scenario 3-1 and square 1 and 3 are both better in terms of service performance compared to scenario 2-1. Squares 2 and 4 are sufficient to meet the service level requirements and an improvement compared to the current situation (scenario 2-1) in terms of costs would be square 1 or 2. Concluding, we expect that it is possible to decrease the total inventory of scenario 3-1 and find a scenario which would be plotted in one of the four squares. In the next subsection we will discuss the new scenarios.

Furthermore, the inventory costs represent the biggest portion of the total costs followed by the transport cost, as presented in Figure 4.3. If we conduct a sensitivity analysis on the rent cost percentage and transport rates we find that scenario 3-1 has the same costs when a rent percentage of less than 1% per year is used. Furthermore, if the transport rates (standard and express) increase these rates have to increase with 9.075% to have equal costs for scenario 3-1 and 2-1.

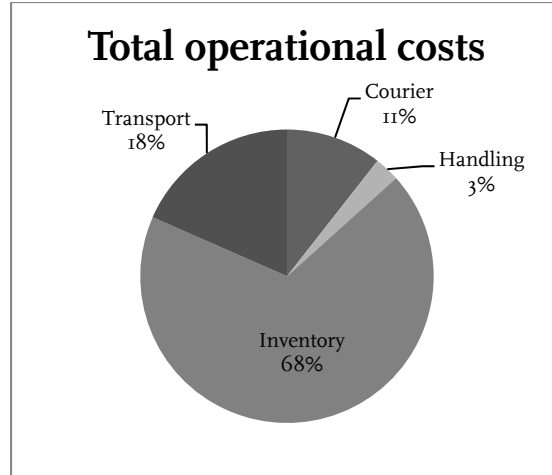

Figure 4.3: Division of total cost

### 4.3 Modified design results

As concluded earlier, we expect that a decrease of total stock of scenario 3-1 will lead to less total costs and to sufficient service level performance. We have identified two additional three-echelon scenarios, a scenario in which we have decreased the inventory at the EDC and a scenario in which we also decrease the EDC inventory and in which we do not hold inventory at the RDC for each SKUs. We identify the scenarios by 3-2 and 3-3.

The procedure for scenario 3-2 will lead to more inventory holding cost compared to scenario 2-1. In scenario 3-2 we use the basestock levels of 3-1 als starting point and if we have more stock in the EDC than in the three RDCs together we subtract the RDC basestock level from the EDC basestock level. As a result this scenario leads to less EDC stock compared to scenario 3-1. Next, scenario 3-3 will have exactly the same inventory holding costs as scenario 2-1 because then RDC only hold inventory for an SKU if this basestock level would be deductible from the EDC basestock level. In scenario 3-3, the basestock levels of scenario 3-1 are the starting basestock levels. If the an EDC basestock level is deductible with the total stock in the RDCs this is done but if this is not possible the EDC basestock level will remain the same and the RDC basestock levels are set to zero. The performance of scenario's 3-2 and 3-3 is presented in Table 4.5. The four discussed scenarios are plotted in a service level versus costs scatter plot in Figure 4.4

$WR$	Set of RDCs
$W$	Set of warehouse with indices $j=0$ for the EDC
$K$	Set of SKUs
$S_{j,k}$	Basestock levels of scenario 3-1
$S_{j,k}^*$	New basestock levels



*Procedure to determine basestock levels for scenario 3-2*

For each  $k \in K$   
 If  $\sum_{j \in WR} S_{j,k} < S_{0,k}$  do  
 $S_{0,k}^* = S_{0,k} - \sum_{j \in WR} S_{j,k}$   
 End if  
 End for

*Procedure to determine basestock levels for scenario 3-3*

For each  $k \in K$   
 If (  $\sum_{j \in WR} S_{j,k} < S_{0,k}$  ) do  
 $S_{0,k}^* = S_{0,k} - \sum_{j \in WR} S_{j,k}$   
 End if  
 For each  $j \in WR$   
 If (  $S_{j,k} > 0$  and  $S_{0,k}^* = S_{0,k}$  ) do  
 $S_{j,k}^* = 0$   
 End if  
 End for  
 End for

Scenario 3-2		Total	Courier	Handling	Inventory	Transport	Perf.	2 hour	4 hour	NBD
	UK	14,10	0,06	0,46	13,45	0,12	99,07%	100,00%	97,14%	99,15%
	Iberia	17,72	1,43	0,51	14,09	1,69	99,01%	97,73%	99,94%	99,04%
	Nordic	14,96	0,49	1,09	10,60	2,79	99,20%	100,00%	98,48%	99,19%
	Other	82,12	8,65	1,83	60,81	10,83	98,92%	98,19%	99,66%	98,92%
	<b>Total</b>	<b>128,91</b>	<b>10,63</b>	<b>3,90</b>	<b>98,95</b>	<b>15,43</b>	<b>98,98%</b>	<b>98,22%</b>	<b>99,65%</b>	<b>98,99%</b>

Scenario 3-3		Total	Courier	Handling	Inventory	Transport	Perf.	2 hour	4 hour	NBD
	UK	4,69	0,06	0,36	2,02	2,25	97,44%	100,00%	97,14%	97,44%
	Iberia	8,26	1,43	0,38	4,23	2,21	97,68%	97,73%	99,19%	97,10%
	Nordic	4,98	0,49	0,32	1,53	2,65	97,26%	100,00%	98,48%	97,21%
	Other	81,52	8,65	1,80	60,46	10,61	97,30%	98,19%	99,66%	97,16%
	<b>Total</b>	<b>99,45</b>	<b>10,63</b>	<b>2,86</b>	<b>68,24</b>	<b>17,72</b>	<b>97,31%</b>	<b>98,22%</b>	<b>99,65%</b>	<b>97,19%</b>

**Table 4.5: Performance of scenario 3-2 and 3-3**

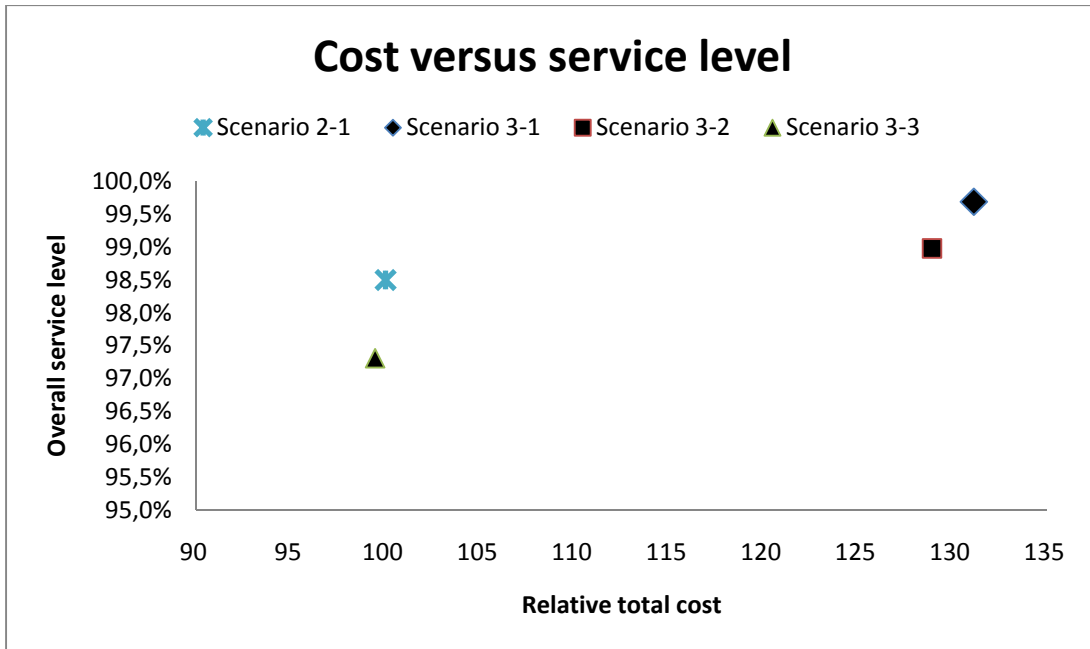

Figure 4.4: Cost and service level comparison scenarios

From the results can be concluded that both new scenarios perform better than the old three-echelon scenario in terms of costs. If we compare scenario 3-3 with scenario 2-1 we find lower but sufficient service levels performance and a small cost reduction. Scenario 3-3 indicates that a three-echelon scenario should be able to perform better on both cost and performance compared to the current two-echelon structure. It has to be noticed that we do not take emergency shipment costs into account, as a result of this a decrease in service level means a decreased number of shipments and thus a decrease in transport costs. For example, we see a 2% reduction of transport costs in region “other” for scenario 3-3 compared to 2-1 and also a 2% reduction in service level.

Based on the volume and higher cost reduction on transport costs for the UK region we expect to gain the most of an RDC in the UK. To isolate the effects of an RDC in the UK we will investigate a scenario with only a RDC in the UK, scenario 3-4. The basestock determination policy of scenario 3-3 will be used, due to the fact that no RDCs are placed in the Nordics and Iberia both the inventory at the EDC and RDC in the UK can be different than in scenario 3-3.

Scenario 3-4	Total	Courier	Handling	Inventory	Transport	Perf.	2 hour	4 hour	NBD
	UK	8,67	0,06	0,46	7,69	0,46	99,27%	100,00%	97,14%
Iberia	7,79	1,43	0,34	3,67	2,36	97,74%	97,73%	99,94%	97,16%
Nordic	4,51	0,49	0,26	1,07	2,69	97,27%	100,00%	98,48%	97,40%
Other	77,12	8,65	1,83	55,82	10,83	99,48%	98,05%	99,66%	99,03%
<b>Total</b>	<b>98,09</b>	<b>10,63</b>	<b>2,89</b>	<b>68,24</b>	<b>16,33</b>	<b>99,69%</b>	<b>98,11%</b>	<b>99,63%</b>	<b>99,86%</b>

Table 4.6: Performance scenario 3-4

#### 4.4 Sensitivity analysis

The main change from a two- to a three-echelon scenario in terms of costs are the decrease in transport and equal or increasing inventory costs. At the basis of these cost types are transport rates and the inventory holding rent percentage. For our earlier presented results we used a rent percentage of 15% and the actual TLP transport rates. The result of a two-dimensional sensitivity analysis on the inventory rent costs and transport cost is presented in Figure 4.5. On the horizontal ax the change in transport rates is stated and on the vertical ax the rent percentage at which the presented scenario has equal total cost than the two-echelon scenario 2-1. For example if the transport rates do not change (0%) we need a rent percentage of 1.35% to have equal costs for scenario 2-1 and 3-1. Furthermore, if transport rates would double still a very low rent percentage should be used to have equal costs in the scenario 2-1 and 3-1 or 3-2.

In scenarios 3-3 and 3-4 are the transport costs strictly smaller than in scenario 2-1 and the inventory holding costs equal. Therefore, we only conduct an analysis on the transport rates and its effect on the total cost reduction of the scenarios 3-3 or 3-4 compared to 2-1. In Figure 4.6 the change in transport rates is presented on the horizontal ax with the total cost reduction represented on the vertical ax. For example if the transport costs would double the cost for scenario 3-3 and 3-4 are 1,17% and 3,38% below the cost of scenario 2-1.

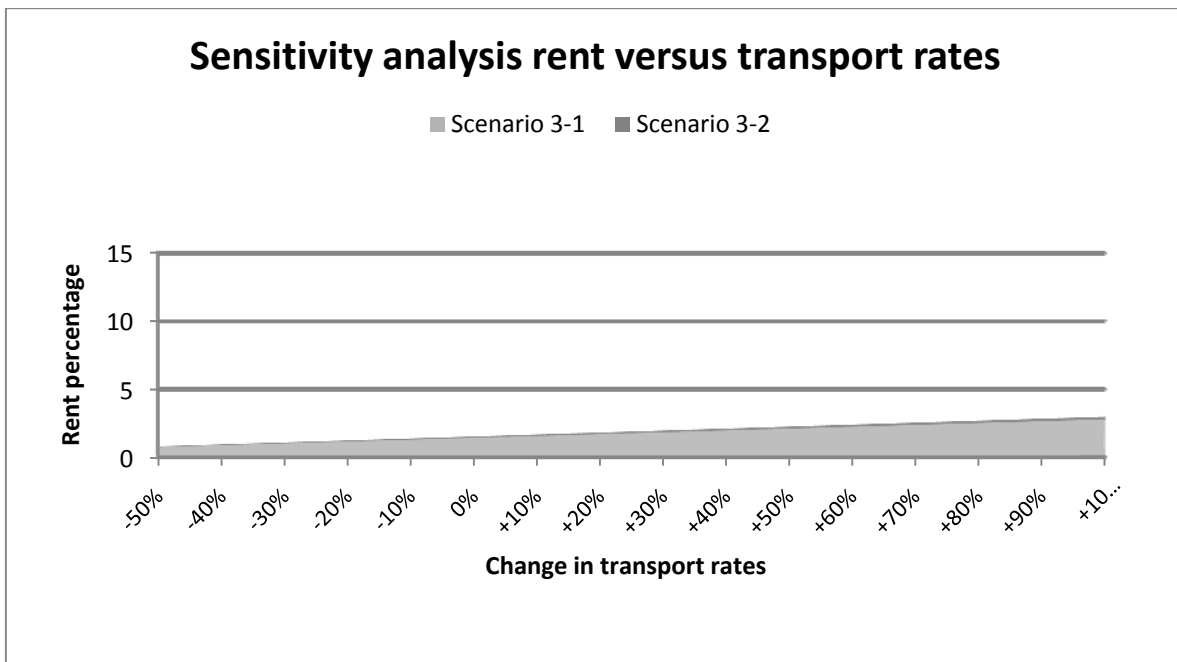

Figure 4.5: Change in transport rates versus rent cost to have equal total costs compared to scenario 2-1

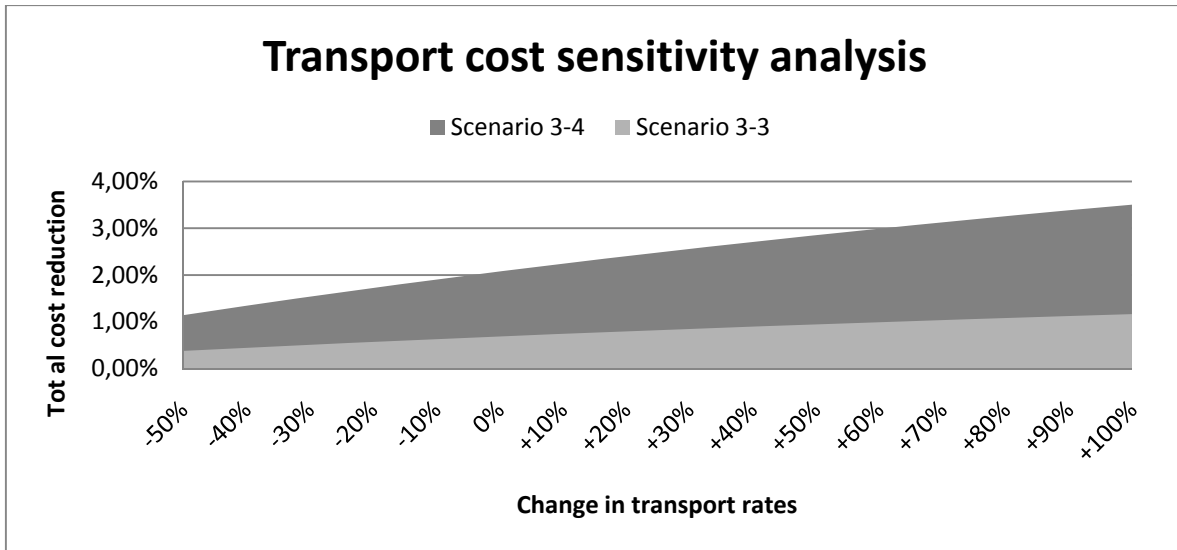

Figure 4.6: Change in transport rates versus total cost reduction compared to scenario 2-1

From both analyses' can be concluded that the inventory rent percentage has a minor influence on the interpretation and conclusion of the results. Furthermore, the transport rates do have an influence on the difference in costs between a two- and a three-echelon scenario. If transport rates increase the three-echelon scenarios will perform relatively better and vice versa. Furthermore, it has to be noticed that we did not take the effect of demand rate changes due to changing volumes on specific lanes/transport modes into account.

#### 4.4.1 Emergency shipment costs

The cost of an emergency shipment are more than the cost of a regular delivery. In the earlier presented results we did not take the emergency costs into account. It is likely to assume that an emergency shipment within a country are less than an emergency shipment from the EDC in Helmond. In Figure 4.7 the result of a sensitivity analysis on the difference between an emergency shipment from the EDC and an RDC is presented. On the horizontal axis the percentage indicate the cost of an emergency shipment from an RDC within a region compared to the cost of an emergency shipment from the EDC outside the region. For example the 50% on the horizontal axis means that the cost of a emergency shipment from the within the UK are half the cost of an emergency shipment from the EDC to the UK. From the figure it is concluded that the bigger the difference between the cost of an emergency shipment within the region and from the EDC the more the three-echelon network is favourable. Furthermore, both scenarios presented in Figure 4.7 have three lines which represent different cost levels of an emergency shipment from the EDC, the dotted lines represent the high and low level of the EDC emergency shipment cost. In scenario 2-1 we do not have RDCs thus the three lines do not have a slope of zero. The three lines of scenario 3-4 do have different slope, the low level has a slope of -0,0078 per 10% decrease in emergency shipment costs within the region. For

the middle scenario the slope is  $-0,0156$  and for the high level  $-0,0234$ . Concluding, with the same ratio of RDC versus EDC the higher the level of emergency shipments costs the more scenario 3-4 is in favour of scenario 2-1 in terms of cost.

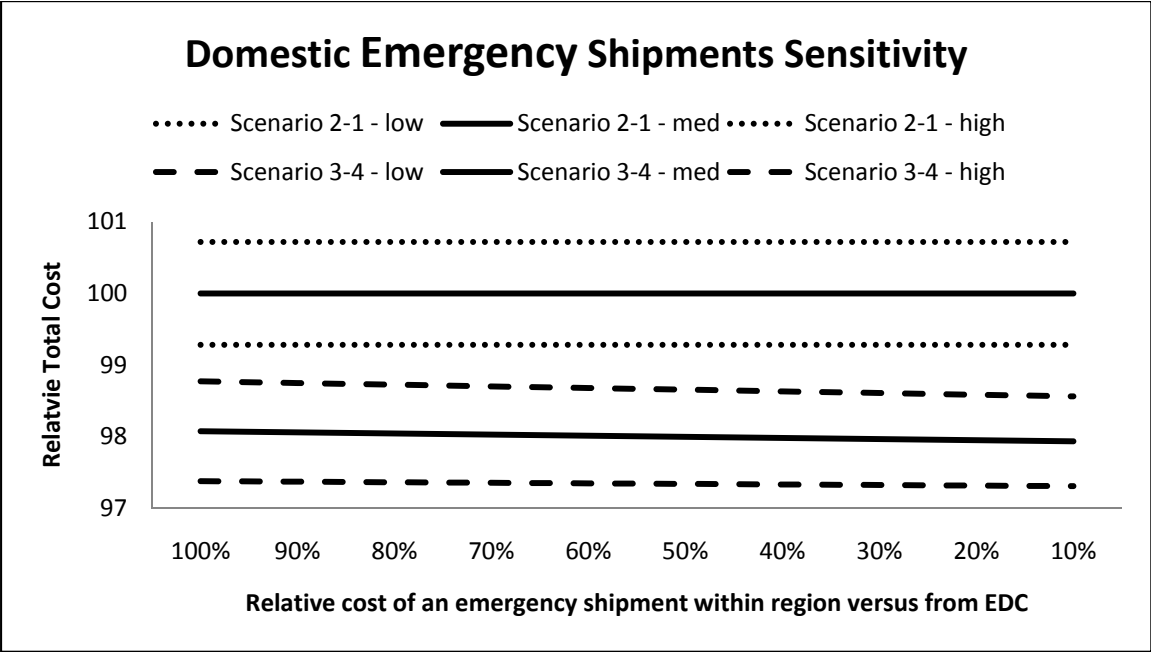

Figure 4.7: Emergency shipment cost sensitivity

### 4.5 Conclusion

To conclude on the results, the performance of each scenario in terms of cost and service level is presented in Figure 4.8. In the middle of the four areas we have the two-echelon scenario 2-1 and a three-echelon scenario in area 1 and 2 which mean a cost reduction and service level improvement or reduction. The high service level performance of scenario 3-4 can partly be explained by the increase in UK service performance which can be explained by the fact more inventory is held in the region. Furthermore, the NBD performance in the other regions is not decreased much and even increased in the region “other.” Explanation of this lies in the fact that in scenario 3-4 in case of EDC shortage this will be first allocated to replenishment demand, the RDC, and only if there is still unallocated shortage left this would be allocated to a non-UK customer.

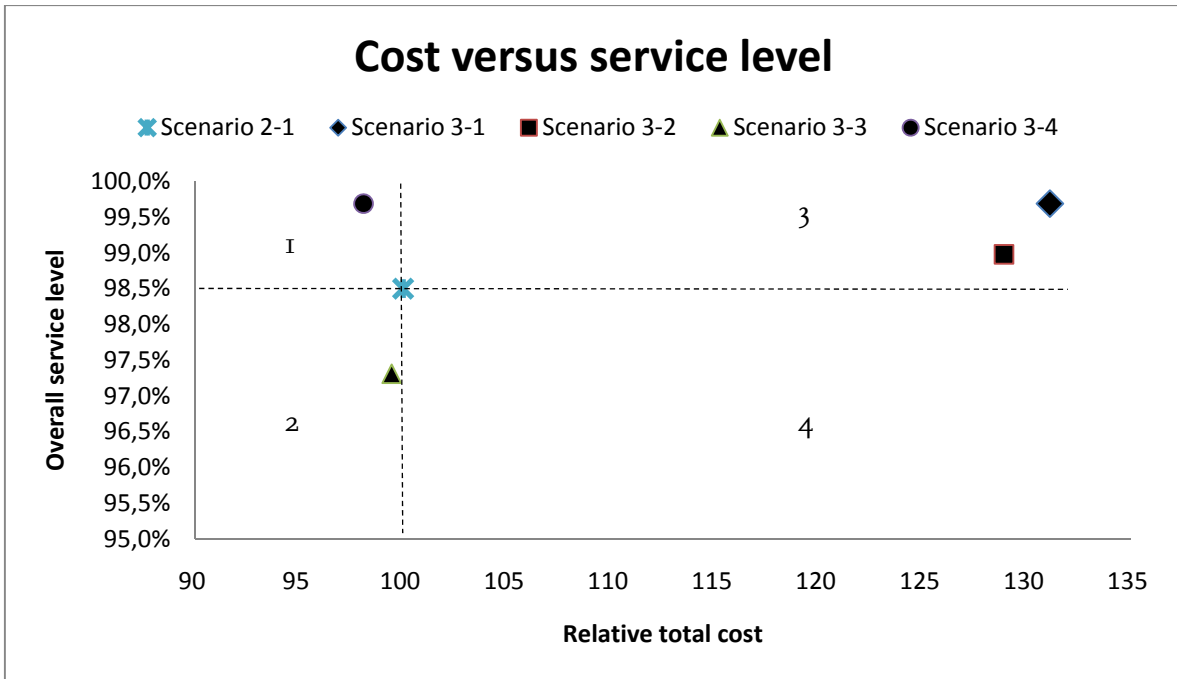

Figure 4.8: All scenario cost versus service level overview

## 5. Conclusion and recommendations

This final chapter draws a conclusion of this project. Furthermore, recommendations are made for LNEP and for further scientific research.

### 5.1 Conclusion

In this thesis, we studied the network design for spare parts of TLP customer LNEP where inventory-holding costs are taken into account. As described in Section 1.2 the current spare parts network consists of one EDC and 145 SPCs near to the customers. The conclusions that can be drawn are now discussed per research question.

*Is it for LNEP beneficial to use regional or country DC's and if: how, how many and where?*

It has to be noted that we do not know if the scenarios are efficiency frontiers which is a scenario performs best in terms of service given the total costs or vice versa. In practice this could mean that there is for example a two-echelon scenario which performs better in terms of cost and/or service. The inventory determination procedure is important for performing the best given a certain budget or desired service level. In the two-echelon scenario we used the greedy approximation algorithm of Reijnen et al. (2009). Reijnen et al. (2009) have evaluated the performance of this algorithm and state that for practical purposes the performance is good enough. The model of Reijnen et al. (2009) is single-echelon we used it for a multi-echelon purpose. However, for the two-echelon scenario we expect this to have minor influence because it will only have influence on the EDC basestock levels and more than 85% of the EDC demand comes from NBD customers and can be seen as a single-echelon model. For the three-echelon scenarios this does not hold but we assume that the two-echelon scenario is not far from its efficient frontier. Consequently, from the two- and three-echelon scenario comparisons in Chapter 4 we can conclude that there are three-echelon scenarios which are beneficial in terms of cost and or service level performance (see Figure 4.7). As replenishment policy we would suggest using the standard/road network and the answer on the “*how many*” question we can conclude maximal one per region, this will be further discussed in Section 6.3 where the recommendations for LNEP are presented. The answer on the *where* question would be: a city, reachable with a two business day leadtime via the standard/road network and a city which is centrally located for emergency and courier shipment for which the costs are distance based.

*What is the influence of taking, next to strategic, tactical cost into account for the design of a spare parts network?*

Successful supply chain management requires decisions on three traditional hierarchical levels and with respect to three time horizons: (1) strategy or design, (2) tactical or planning, and (3) operations (Chiani et al. 2004). The research on supply chain management for spare parts is

mainly limited to the tactical and operational level (e.g. inventory, service or forecasting) (Wagner and Lindemann, 2008). An important decision at the strategic level for service supply chains is the number and geographical position of locations and its demand allocation. From our results we can conclude that if we would not take the tactical cost: inventory holding into account we would end up with the conclusion that three-echelon network will outperform a two-echelon network. This research did take inventory holding costs into account which made it possible to draw a more nuanced conclusion. Based on this thesis it can be stated that the influence of taking the tactical cost factor inventory into account during spare parts network design is very important.

*What is the influence and sensitivity of the different cost factors on the optimal spare parts network design?*

In the previous chapter a sensitive analysis on the transport and inventory costs for our scenarios was conducted. From both analyses could be concluded that the rent percentage on holding inventory has a minor influence on the interpretation and conclusion of the results. Furthermore, the transport rates do have an influence on the difference in costs between a two- and a three-echelon scenario. If transport rates increase the three-echelon scenarios will relatively perform better and vice versa.

Additionally, from the sensitivity analysis on the cost of an emergency shipment it is concluded that the bigger the difference between the cost of an emergency shipment within the region (from an RDC) and from outside the region (EDC) the more the three-echelon network is favourable. Furthermore, the higher the level of emergency shipments costs the more a three-echelon scenario gets in favour of a two-echelon scenario in terms of cost.

### **5.3 Recommendations for the LNEP network**

In this rapport three-echelon networks were investigated and compared with the current two-echelon network of LNEP. For three regions the use of an RDC was investigated: (1) UK, (2) Iberia, and (3) the Nordics. From the results, it could be concluded that using an RDC in the UK and no RDC in the other two regions would perform the best in terms of costs. The scenario with only an RDC in the UK outperforms the current two-echelon scenario on service levels and costs. Based on the fact that this scenario outperforms on service level we can assume that inventory can be decreased which will further decrease the total cost. Furthermore, emergency costs were not taken into account and it can be assumed that in a three-echelon scenario an emergency shipment sometimes can be fulfilled from the RDC which will be less costly than an emergency shipment from outside the region (from the EDC). Based on this and the fact that we found a scenario which is plotted in area 1 of Figure 4.7 we could recommend using an RDC in the UK. However, the lower bound of reduction in total cost is 2%. A



percentage of 2% is quite low but we expect that this percentage can increase if the inventory policies would be further optimized and the current 2% reduction would be achieved by changing the network design in one of the regions in the EU theatre. Furthermore, we expect the demand to increase which will increase the number of items which would be held on stock at the RDC and thus the benefits of an RDC. Additionally, from a sustainability perspective, a three-echelon scenario performs better due to the shift from air to road transport. Finally, it is recommended to change the network design for the UK region into a three-echelon network.

More general we can state that a RDC is beneficial for regions for which holds: (i) relative far from the EDC and high parcel rates for sending from the EDC; and (ii) enough NBD demand to generate the consolidation effect on RDC replenishment. If both cases hold for a region there is the possibility that the increase in inventory holding and handling costs will be less than the decrease in transportation costs for SPC replenishment and NBD order fulfilment.

## 5.2 Recommendations for further scientific research

Analysis of the results showed that a network design approach which takes inventory costs into account is necessary because the inventory costs are important in spare parts networks. From literature also, is concluded inventory cost in spare parts networks is an important cost factor that should be taken into account for determining the *optimal* design of a spare parts network (Arts, 2010a). As currently the literature about integrated network design approaches is limited, it is recommended to extend research in this area.

If LNEP would use an RDC in the UK a multi-echelon inventory model with lateral transshipment and time based fill rates would fit perfectly the situation. Currently, no such model can be found in literature and thus it is recommended to further extend research in the area of inventory policies with the use of lateral transshipments and time based fill rates.

## References

- AberdeenGroup. *Integrating spare parts planning with logistics*. Supply Chain Management Review, July, 2008
- Arts, R.M.J., (2010a) '*Design of Spare Parts Networks: A Literature Review*', Eindhoven University of Technology
- Arts, R.M.J., (2010b) '*TLP Project Charter: Design of Spare Parts Networks*', TLP, ( 28-1-2010)
- G. Chiani, G. Laporte, and R. Musmanno. *Introduction to logistics systems planning and control*. Wiley, 2004.
- M.A. Cohen. *Service management: building profits after the sales*. Supply Chain Management Review, 7 (1), 2003.
- Dennis, M.J., and Kambil, A., *Tapping the service supply chain*. Line 56, 7 June, 2007
- Mitroff I.I., Betz F., Pondy L.R., Sagasti F., (1974) '*On managing science in the systems age: two schemas for the study of science as a whole systems phenomenon*', Interfaces 4 (3), p. 46-58
- Reijnen, I.C., Tan, T., and van Houtum, G.J. (2009) '*Inventory planning for spare parts networks with delivery time requirements*', Working paper, Eindhoven University of Technology.
- S.M. Wagner and E. Lindemann. A case study-based analysis of spare parts management in the engineering industry. *Production Planning and Control*, v19 i4, 2008.

## List of concepts

**Base stock policy** is also known as the one-for-one replenishment policy, because once an SKU  $k$  is used to fulfill a customer order, immediately a new SKU is ordered to replenish the warehouse

**Echelon** is a layer in the distribution network that consists of stocking points with the same function

**Efficient frontier** is a scenario which performs best in terms of service given the total costs or vice versa

**Emergency shipment** is defined as a shipment by the central source in case none of the hubs present in the lateral transshipment array of customer group  $n$  has SKU  $k$  on stock

**Greedy algorithm** is an approximation technique and known as the 'biggest-bang-for-the-buck' method: it iteratively chooses the alternative that provides the 'biggest-bang-for the-buck' until a certain stopping criterion is reached

**Lateral transshipment** is defined as the provisioning of a part by a stocking point to a customer of another stocking point that is out of stock

**Network design study** is defined as designing the network with stocking points to fulfill customer demand. This requires determining the number and locations of stocking locations but also deciding inventory ordering policies and determining the method to dispatch the required parts from facilities to the customers in need (Candas and Kutanoglu, 2006).

**Scenario analysis** is defined as the process of analyzing the best suited network by considering alternative possible outcomes of scenarios. These scenarios consist of different number and locations of hubs. By using a logical scenario set, a near-to-optimal network design can be found.

## List of abbreviations

CQM	Centre of Quantitative Methods
TLP	Transport and Logistics Provider
EDC	European Distribution Centre
EMEA	Europe, Middle East and Africa
EU	Europe
LNEP	Leading Network Equipment Provider
NBD	Next Business Day
RDC	Regional Distribution Centre
RFD	Rapid Failure Depot
SPC	Spare Parts Centre
SKU	Stock Keeping Unit
UK	United Kingdom