

**MASTER**

**Traffic data collection framework  
freight traffic data in the city of Eindhoven**

Perez Martinez, A.

*Award date:*  
2015

[Link to publication](#)

**Disclaimer**

This document contains a student thesis (bachelor's or master's), as authored by a student at Eindhoven University of Technology. Student theses are made available in the TU/e repository upon obtaining the required degree. The grade received is not published on the document as presented in the repository. The required complexity or quality of research of student theses may vary by program, and the required minimum study period may vary in duration.

**General rights**

Copyright and moral rights for the publications made accessible in the public portal are retained by the authors and/or other copyright owners and it is a condition of accessing publications that users recognise and abide by the legal requirements associated with these rights.

- Users may download and print one copy of any publication from the public portal for the purpose of private study or research.
- You may not further distribute the material or use it for any profit-making activity or commercial gain

**Take down policy**

If you believe that this document breaches copyright please contact us providing details, and we will remove access to the work immediately and investigate your claim.

# TRAFFIC DATA COLLECTION FRAMEWORK

## Freight traffic data in the city of Eindhoven



**Alberto Perez Martinez**  
MSc. Construction Management and Engineering  
2014-2015



## **ACKNOWLEDGEMENTS**

I take this opportunity to express gratitude to all of the Build Environment Faculty members for their help and support. I also thank the Municipality of Eindhoven (Gemeente Eindhoven) for the project opportunity. In addition, a thank you to my supervisors Tao Feng, Han Qi, and Jan-Willem Hommes for their guidance in the entire process.

I wish to express special thanks to the Mexican program “Summons for the Formation of Quality Human Capital through Doctoral and Masters Programs Abroad. CONACYT – Government of the State of Quintana Roo 2013” for the scholarship that made my master studies possible.

I also thank my parents for the unceasing encouragement, support, love, and attention. Also a thank you to all my friends for their company and support in this international venture.

Finally, I also place on record my sense of gratitude to all who directly or indirectly have contributed to this thesis.



# TRAFFIC DATA COLLECTION FRAMEWORK

## Freight traffic data in the city of Eindhoven

**Alberto Perez Martinez**

MSc. Construction Management and Engineering

### Graduation committee

Chairman:	prof.dr.ir. Bauke de Vries	– TU/e
1 <sup>st</sup> supervisor:	dr. Qi Han	– TU/e
2 <sup>nd</sup> supervisor:	dr. Tao Feng	– TU/e
3 <sup>rd</sup> supervisor:	ir. Jan-Willem Hommes	- Gemeente Eindhoven

**TU/e** Technische Universiteit  
Eindhoven  
University of Technology



July 13<sup>th</sup>, 2015



# Contents

- Summary .....5
- Abstract .....7
- 1 Introduction .....9
  - 1.1 Problem definition.....9
  - 1.2 Research question .....10
  - 1.3 Research design.....10
  - 1.4 Expected results .....11
- 2 Glossary .....13
- 3 Monitoring the traffic network: Freight traffic data collection .....19
  - 3.1 Traffic data collection methods.....19
    - 3.1.1 In-situ techniques .....20
    - 3.1.2 On-board techniques .....26
    - 3.1.3 Traffic data collection systems .....29
    - 3.1.4 Overview of traffic collection methods.....30
  - 3.2 Freight traffic data and urban development.....31
    - 3.2.1 Traffic Data .....31
    - 3.2.2 Freight traffic data and urban transport development .....33
    - 3.2.3 Considerations of the literature study .....40
- 4 A combined AHP and QFD methodology for data collection technique evaluation .....41
  - 4.1 Introduction .....41
  - 4.2 The AHP and QFD methodologies .....43
    - 4.2.1 Analytic hierarchy process (AHP).....43
    - 4.2.2 Quality function deployment (QFD).....44
    - 4.2.3 AHP and QFD .....46
  - 4.3 Combined AHP and QFD methodology.....46
    - 4.3.1 AHP for prioritizing freight traffic criteria .....46
    - 4.3.2 QFD for ranking traffic data collection methods .....51
  - 4.4 Result analysis .....53
    - 4.4.1 AHP results .....53
    - 4.4.2 QFD results .....61
  - 4.5 Discussion .....66
- 5 Conclusion. ....69
  - 5.1 Societal Relevance .....69



5.2	Scientific Relevance .....	69
5.3	Beneficiary Relevance.....	69
	References.....	71
	Appendices.....	83

## Summary

The rapid urban growth generates a high demand for urban mobility, transport, and logistics. These three components are part of the urban transport development sector. In The Netherlands authorities aim for an economic, social, and environmental sustainable transport network. Decision-makers of the urban development sector take this into account when implementing new policies, integrating the city needs with the population interests.

The policy-making process of the city of Eindhoven targets a smarter, safer, and more sustainable city. To achieve this, the city needs to collect traffic information that will serve as input for a complex policy-making process. This thesis aims to identify an adequate method to collect freight traffic data in the city. Freight traffic activity is the targeted sector due to its important role in urban transport. A ranking of the different freight traffic data collection methods available is obtained as a result of this investigation. The ranking considers stakeholders' interests, traffic data importance, and individual features of the methods.

First, a literature review provides the basis for monitoring the traffic network using freight traffic data. Then, a combination of the Quality Function Deployment (QFD) and the Analytic Hierarchy Process (AHP) is used to rank the available traffic data collection methods. The AHP identifies and prioritizes the urban transport problems related to freight traffic. AHP also considers the opinion of different stakeholders. QFD is used in two phases, phase I ranks the freight traffic data and phase II the methods to collect it.

This research focuses on four main sectors of urban transport development that contribute to the objective of a sustainable urban growth. The sectors are: environment, innovation and technology, infrastructure, and policy-making. Their description considers the problems caused by the impact of freight traffic. The research then identifies the traffic data and traffic data collection methods. The aim is to contribute to solving these problems in Eindhoven. Therefore, European studies are the main input for the literature review. The problems, the traffic data, and the methods are applicable for many cities. Thus, some studies from the literature review are from continents different from Europe.

The traffic data described here is a selection of a big variety of existing traffic data. Eighteen traffic data are analyzed: accidents, delay, driving behavior, noise level, number of journeys, queue length, road condition, traffic flow, traffic volume, travel direction, travel time, traveled distance, vehicle classification, vehicle density, vehicle identification, vehicle location, vehicle speed, and vehicle weight. The review also describes fifteen different methods to collect traffic data: pneumatic tubes, piezoelectric sensors, ILD, video image sensors, magnetic sensors, manual counts, infrared sensors, microwave radar, laser sensors, acoustic sensors, surveys, and probe vehicles (GPS, cellphone, RFID, moving observer).

The selection of the transport sectors, the traffic data, and the data collection methods take into account the urban development of the city of Eindhoven. These three elements are the base for the AHP and QFD methodology used in this research. The AHP questionnaires were only answered by Dutch stakeholders from the freight transport sector. The surveys evaluated eleven freight traffic related problems originated from the four urban transport development sectors. The problems are: congestion, noise and air pollution, safety risks, inefficient routes

## Summary

and logistics, inefficient infrastructure (roads, intersections, and parking), lack of integrated policies and regulations. The obtained results show that the most important problems associated to freight traffic are: safety risks, logistics inefficiency, and congestion.

Phase I and phase II of the QFD method are filled in by the author of this thesis. The author adopted the role of expert on freight traffic data collection. The first phase of the QFD rank the freight traffic data (technical requirements) using the AHP results as customer requirements. The obtained results categorize vehicle speed, traffic volume, vehicle classification, number of journeys, and travel time as the five most important freight traffic data. Finally, a second QFD phase rank the traffic data collection methods using the first phase results (freight traffic data) as customer requirements. This second phase of the QFD take into account general characteristics of the methods (accuracy, installation, and performance) and their suitability for the city of Eindhoven. The results of this second phase are the main findings of this research: the ranking of traffic data collection methods for collecting freight traffic data in the city of Eindhoven.

The results show that the three most adequate methods for the city are: GPS-probes, video cameras, and mobile-probes. Microwave, infrared, and lasers sensors are the next methods in the ranking. The first three methods are proposed for an integrated real-time traffic monitoring system (ITS). And the other three methods are proposed for site-specific and period based analyses.

A clear picture of the freight traffic network in Eindhoven contribute to the analysis of the ongoing problems. Then policy makers can implement measures and regulations to improve freight transport. Collecting freight traffic data has a double function in the decision-making process. Not only provide the information for new measures and policies, but also evaluate the implementation of this measures.

## Abstract

This thesis investigates traffic data collection methods to obtain freight traffic data in the city of Eindhoven. The research is done as a traffic data collection framework for The Netherlands. Of particular interest are the importance of the traffic problems of the urban freight transport sector and the freight traffic data needed for their analysis. Traffic data collection methods are evaluated as part of a general solution for the urban transport sector improvement, instead of looking for a particular traffic problem solution. This paper presents a combination of the Quality Function Deployment (QFD) and the Analytic Hierarchy Process (AHP) for a traffic data collection method selection process. The AHP integrates the opinion of different stakeholders to identify and prioritize the urban transport problems. Two phases of the QFD rank the freight traffic data and the methods to collect the data. The main findings indicate that probe vehicles (GPS-based and cellphone-based) are an adequate freight traffic data collection technique for the city of Eindhoven. This is related to their capacity to collect speed, journeys, time, and classification data. Furthermore, the results indicate that all stakeholders involved in the freight transport sector of The Netherlands consider the reduction of congestion, pollution, and safety risks as the most important problems to solve.

## Abstract

## 1 Introduction

### 1.1 Problem definition

The rapid urban growth generates a high demand for urban mobility, transport, and logistics. Several studies (Chourabi et al., 2012; Chu, Wang, & Leckie, 2012; Naphade, Banavar, Harrison, Paraszczak, & Morris, 2011) suggest that population growth increase stress in urban infrastructures and services (e.g. water supply, energy supply, housing, transportation, roads, safety, etc.). Human activity has caused unprecedented environmental change all over the world. Thus, every country needs integrated policies to improve the quality of life of citizens.

Urbanization and economic development go hand in hand. Economic activities and consumption patterns of cities become larger, more intense, and more complex. This increased activity, translates into increased use of large trucks for delivery. These vehicles, also called heavy good vehicles (HGVs), impose a bigger contribution for negative environmental impacts than passenger vehicles. Some delivery companies have already significant progress in developing sustainable transport systems. Aided by policy-making, authorities can increase sustainability and efficiency in the freight transport sector.

Policy-making is based on a clear perception of the status quo of the cities. A sustainable policy-making process requires knowledge about the needs and demands of the population. Authorities should understand the interactions between local, regional and national governments and between the private and public sectors (Pentikousis, Zhu, & Wang, 2011). The sustainability of urban transport systems is influenced by factors such as: travel behavior patterns, transportation networks, energy consumption patterns, technological progress, land use, etc. (Fujiwara & Zhang, 2013).

Policy-making is a decision making process. The decision-making process represents a problem solving process preceded by a problem finding process. This thesis focus in the early stage of the typical decision making process (see figure 1-1). The goal is contribute to create an overview of the freight traffic network. To do this, a method to collect traffic data needs to be identified.

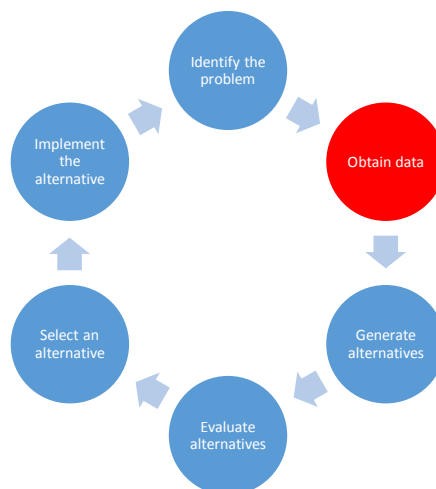

Figure 1-1 Decision-making process (Quintero, Konaré, & Pierre, 2005)

## 1.2 Research question

The Municipality of Eindhoven needs to identify an adequate method to collect traffic data in the city. The collected traffic data would be the input for a complex policy-making process. Policy-making aims to optimize the existing transport infrastructure in a sustainable way.

This research contributes to overview the city's freight traffic network status. Freight traffic data of Eindhoven is the framework for collecting general traffic data in the Municipality. The goal of this paper is to answer the following question:

*What is the most adequate method for freight traffic data collection in the city of Eindhoven?*

To solve this question, the research is aided by the following sub-questions:

1. *What are the available methods to collect freight traffic data?*
2. *What type of traffic data is needed to analyze and optimize the freight transport sector?*
3. *What are the most concerning freight traffic related problems in The Netherlands?*
4. *What are the current data collection methods in Eindhoven?*
5. *Which of the available data collection methods is better?*

## 1.3 Research design

Most of the studies involving traffic data collection methods investigate a particular traffic problem (e.g. emissions, congestion, etc.). Other studies investigate a specific traffic data collection method or a specific traffic data. This studies display few general features of the methods. This research is one of its kind. Traffic data collection methods are evaluated as part of a general solution for the urban transport sector improvement,

This research requires a rational approach for a decision-making process. Multi Criteria Evaluation (MCE), Conjoint Analysis, and Quality Function Deployment (QFD) are three decision-making methods. MCE has two main techniques: the Analytic Hierarchy Process (AHP) and the Analytical Network Process (ANP). AHP and QFD methodologies are the most suitable approaches for this investigation. AHP and QFD methods have been combined before in several studies (Bhattacharya, Geraghty, & Young, 2010; Chan & Wu, 2002; Ho, He, Lee, & Emrouznejad, 2012; Liao & Kao, 2014)

The utilized QFD and AHP combined approach of this thesis is described next. First, AHP prioritizes the problems of the urban freight transport sector. AHP also integrates the different freight transport stakeholders' interests. Then, a first phase of the QFD method rank freight traffic data using the AHP results. Finally, a second QFD phase rank the traffic data collection methods using the QFD first phase results.

#### 1.4 Expected results

A ranking of the different freight traffic data collection methods is the expected outcome of this investigation. Taking into account stakeholders' interests, traffic data importance and individual features of the methods. Then is possible to select an adequate freight traffic data collection method for Eindhoven. Is difficult to include all features from each data collection method. However, the research design allows to focus on the most important freight traffic data.

Two expected results that contribute to this are:

- The importance of the different urban transport sector problems related to freight traffic.
- A ranking of the different type of freight traffic data.

The importance of the urban problems integrates the opinion of different stakeholders. Thus, the similarities or differences of interests between stakeholders can be analyzed. Future research can identify the optimum method to collect freight traffic data by including a detailed cost/benefit and consumer's acceptance analysis of the data collection methods analyzed in this research.





## 2 Glossary

**Annual Average Daily Traffic (AADT).** The total volume of vehicle traffic of a highway or road for a year divided by 365 days. One of the most important raw traffic datasets for calculating traffic volume and traffic flow. AADT allow engineers to determine the annual growth rate of road traffic. Can also be used for new road construction planning, roadway geometry determination, congestion management, pavement design, etc. Is generally available for most of the European road networks.

**Congestion.** The level at which the transportation system performance is no longer acceptable. Traffic congestion hinders the mobility of any city.

**Freight traffic.** Vehicles transporting goods moving on the road transport network (road, rail, or water canals). In this paper freight traffic refers to heavy good vehicles (HGVs) moving in the road transport network.

**Freight traffic data.** A sub-category of road traffic data, originated from HGVs moving in the road network.

**Freight transport.** The physical process of transporting raw materials and merchandise goods and cargo. This process can be done by sea, land, or air; land transportation can be by train or by truck (lorry). Freight transport is considered one of the major sub-systems of urban transportation. Plays an important role in supporting urban economy development.

**Global Positioning System (GPS).** A space-based satellite navigation system that provides location and time information in all weather conditions, anywhere on or near the earth where there is an unobstructed line of sight to four or more GPS satellites.

**Heavy Good Vehicles (HGVs).** Road vehicles with a total weight above 3.500 kilograms including the weight of the vehicle and the cargo. Trucks and trailers are included in this category.

**Integrated policies.** Policy-making with integration across different modes of transport, government institutions, social groups, and stakeholders. The integration can also be between different policy-making sectors such as: land-use, transportation, and sustainability.

**Intelligent transport systems (ITS).** When information and communication technologies (ICT) are applied in the field of road transport, including infrastructure, vehicles and users, and in traffic management and mobility management, as well as for interfaces with other modes of transport. Advanced transport applications which aim to provide innovative services.

**Intersection.** An area shared by two or more roads, designated for the vehicles to turn to different directions to reach their desired destinations. Intersections directly affect the capacity of the road since overall traffic flow depends on their performance. Drivers have to make decisions in fraction of seconds considering their route, intersection geometry, speed and direction of other vehicles and pedestrians. A small error in judgment can cause severe accidents.

**Mobility.** The ability of a transport system to provide access to jobs, recreation, shopping, and intermodal transfer points. Kaparias et al. (2012) categorize mobility as an essential component of traffic efficiency.

**Policy-making.** The process by which authorities translate their vision into actions to achieve desired outcomes.

**Sustainable development.** To meet the needs of the present without compromising the ability of future generations to meet their needs.

**Traffic.** The movement of vehicles, ships, persons, etc., in an area, along a street, through the air, over a water route, etc.

**Traffic control center (TCC).** The hub or nerve center of most traffic management systems. It is the place where the transport network data is collected and processed. Data is fused with other operational and control data, synthesized to produce traffic information and distributed to the media, other agencies, and the traveling public. It is also where agencies can coordinate their responses to traffic situations and incidents.

**Traffic counts.** Traffic counting determines the number and classifications of vehicles at specific locations and times. Annual traffic volumes of vehicles using the transport network generally come from traffic counts. There are two types of traffic counts: permanent traffic counts and short-period traffic counts. And two methods for counting: manual and automatic.

- *Permanent traffic counts.* Continuous counting of the traffic on roads and highways for the entire year. Typically recorded in intervals of 15 minutes, 1 hour, 7 days, or 1 year. Present a more accurate annual average than short-period counts. Their main objective is to provide the adjustment factors necessary to estimate AADT from short duration counts.
- *Short-period traffic counts.* Provide traffic count information of road segments in a limited time. The collection data period is typically from 1 to 7 days. Data are recorded in 15 min or hourly intervals. The count duration is dependent on the road on which it is located e.g. rural or urban).

**Traffic data.** Information generated from road vehicles moving over the transport network. This data include:

- a. **Accidents.** Incidental and unplanned events in the transport network. Normally measured in amount of crashes per road segment or specific conflict location (intersection).
- b. **Delay.** A period of time by which the total travel time is affected and postponed. Factors that contribute to this are: deceleration and acceleration of the vehicle, waiting in queue, or on the red phase of traffic lights, or to cross by an intersection. Delay is normally calculated as the difference of the travel time of a vehicle and the time that would had under free flow.

- c. **Driving behavior.** A subjective traffic characteristic that reflects the way in which drivers act. Some of the traffic data included in this characteristic are:
- Turning movements in intersections (turning rates).
  - Obeying speed limits (acceleration, deceleration) and traffic rules.
  - Lane changing, merging and diverging.
  - Driver experience, including cautiously driving when adverse road conditions (e.g. wet roads).
  - Competition for parking available spots.
  - Route choice.

“There is no validated methodology to quantify some non-measurable parameters such as driving behavior, pedestrian activity, and road conditions.” (Pandian, Gokhale, & Ghoshal, 2009)

- d. **Number of journeys.** The amount of times a vehicle travel from one place to another, usually a long distance and for a short period of time. In traffic are also known as *trips*. The origin-destination (O-D) of the vehicles is the input information for this traffic data.
- e. **Queue length.** The length covered by a line or sequence of vehicles awaiting their turn to proceed on their route.
- f. **Road condition.** In this paper is the state of the road surface (construction, unpaved, old/new, concrete, asphalt, imperfections, wet/dry).

Other road characteristics are: number of lanes, intersections and interchanges, traffic lights, tunnels, signals, speed limits, route type (highway, road or urban), geometry (grades and curves, turning ratios, involved curvature, slope, etc.).

“There is no validated methodology to quantify some non-measurable parameters such as driving behavior, pedestrian activity, and road conditions.” (Pandian et al., 2009)

- g. **Traffic density (k).** The number of vehicles per unit length of the roadway (see equation 2.1). In traffic flow, the two most important densities are the critical density and jam density. Two indicators of vehicle density are space and time headway.

$$k = \frac{\text{volume}}{\text{road length}} \quad (2.1)$$

*Critical density.* The maximum density achievable under free flow.

*Jam density.* The maximum density achieved under congestion.

*Space headway.* Difference in position between the front of a vehicle and the front of the next vehicle (in meters)

*Time headway.* Difference between the time when the front of a vehicle arrives at a point on the highway and the time the front of the next vehicle arrives at the same point (in seconds).

- h. **Traffic flow (Q).** The rate at which vehicles pass a fixed point normally given in vehicles/hour (see equation 2.2). Traffic flow is generally constrained along a one-dimensional pathway (e.g. a travel lane).

$$Q = \frac{\text{volume}}{\text{hr.}} \quad (2.2)$$

*Free flow.* The condition of traffic flow when vehicles can move without any impedance.

- i. **Traffic volume.** Traffic volume is the amount of vehicles in the network. Traffic counts are the source of this data. Traffic volume can be specified for a road segment or for the entire network. Traffic volumes are normally given per day, week, month, or year time intervals. Annual traffic volume is the most common data used for traffic studies.
- j. **Travel direction.** The course along which the vehicle moves. In road traffic is given by the road lane way. Can be identified with the cardinal directions.
- k. **Travel time (t).** The time necessary to traverse a route between any two points of interest or the duration of each travel journey. When a vehicle's signature is matched at two different sensors, its travel time is obtained (Kwong, Kavalier, Rajagopal, & Varaiya, 2009). Travel time can also be estimated with the average speed of travel and the traveled distance (see equation 2.3).

$$t = \frac{\text{distance}}{\text{speed}} \quad (2.3)$$

- l. **Traveled distance.** Length of travel journey, normally measured in vehicle kilometers traveled (VKT). Leduc (2008) considered VKT a traffic volume indicator. VKT can be considered another measure of flow when multiplying the number of vehicles on a given road or traffic network by the average length of their trips.
- m. **Vehicle classification.** Vehicles are categorized depending on characteristics such as: number of wheels, number of axles, length, weight, etc. Vehicle classification is normally done according to each country's regulations. There are many different classification schemes. In Europe the classifications for vehicle category are based in the United Nations Economic Commission for Europe (UNECE) standards. In the United States of America (U.S.A) vehicle categories are based in the Federal Highway Administration (FHWA) standards. Appendix 1 shows both classification schemes.
- n. **Vehicle identification.** To recognize unique features of a vehicle, as an individual element of the transport network. Vehicle identification is commonly done via a vehicle identification number (VIN), a unique code including a serial number used by the automotive industry to identify vehicles. However some vehicle identification

techniques can recognize vehicles matching its individual signature in two different checkpoints (e.g. the magnetic signature).

- o. **Vehicle location.** The particular place or position occupied by the vehicle. Can be identified from checkpoints in the road, by Global Positioning System (GPS) technology, or estimated using the average speed and direction.
- p. **Vehicle noise.** Is the collective sound energy (sound waves) emanating from motor vehicles (tire/road surface, engine/transmission, aerodynamic, and braking elements). Roadway noise contributes a proportionately large share of the total societal noise pollution. The International System unit of sound level is the decibel (dB).
- q. **Vehicle speed ( $v$ ).** The rate at which vehicles move (km/hr.). Can be calculated as the change of distance with time (see equation 2.4).

$$v = \frac{\text{distance}}{\text{time}} \quad (2.4)$$

*Instant speed* is the speed of a vehicle in a specific time or a specific location. This is the raw data that sensors collect and is the input for time-mean speed and space-mean speed.

*Time-mean speed* is the arithmetic average speed of all vehicles for a specified period of time.

*Space-mean speed* is the average speed of vehicles traveling a given segment of roadway during a specified period of time.

- r. **Vehicle weight.** The heaviness of the vehicle. The vehicle weight varies depending on their vehicle classification (vehicle's chassis, body, engine, engine fluids, fuel, accessories, etc.) and on the dynamic components (driver, passengers and cargo).

**Traffic efficiency.** Express the ease or difficulty to perform travel journeys in the transport network system.

**Transport network.** A spatial network describing a structure which permits vehicular movement. Divided in land, sea, and air transportation networks. This research will refer only to land transportation networks (roads, streets, highways).

**Urban transport development.** The evaluation, assessment, design and construction of transport facilities. Some of these facilities are: streets, highways, bike lanes and public transport lines.



### 3 Monitoring the traffic network: Freight traffic data collection

Freight traffic are heavy good vehicles (HGVs) moving in the road transport network. The rapid increase of freight traffic in urban and metropolitan areas contributes to congestion, air pollution, greenhouse gas (GHG) emissions, noise disturbance, increased logistics costs, and increase of safety risks (Browne, Allen, Nemoto, Patier, & Visser, 2012; Russo & Comi, 2010). The attention over this subject grows every day and an efficient solution for freight distribution is demanding. More transport services might be an easy option to meet this demand. However, an increase in supply is often associated with more pollution and/or more traffic congestion. A better management of transportation services is an alternative strategy to satisfy the increasing traffic demand (Debnath, Chin, Haque, & Yuen, 2014).

Effective urban freight transport planning and management needs to collect freight traffic information. The freight traffic data to be obtained depends on the location and objective of the decision makers. Cities share transport problems and objectives. However, the traffic analysis differ from city to city, due their specific characteristics and interests. A clear picture of the city's freight traffic network contribute to the analysis of the ongoing problems. Then policy makers can implement measures and regulations to improve freight transport. Collecting freight traffic data has a double function in the decision-making process. Not only provide the information for new measures and policies, but also evaluate the implementation of this measures.

In the last years, municipalities of European countries have discovered a lack of data on urban freight transport (Ibeas, Moura, Nuzzolo, & Comi, 2012). Except for data of HGV traffic counts which are relatively uninformative when attempting to develop suitable strategies and policy measures (Cherrett et al., 2012). This results in a limited insight from authorities into urban freight operation patterns.

This chapter presents a background for freight traffic data collection in the Municipality of Eindhoven. Reviewing the methods to collect traffic data and the relationship between freight traffic data and urban planning. The reminder of this chapter is structured as follows. Section 3.1 presents the tools to monitor the freight traffic network: the methods to collect traffic data. And section 3.2 presents the freight traffic data and the impact that freight traffic has on the urban transport development.

#### 3.1 Traffic data collection methods.

The first step for collecting freight traffic data is identifying the available methods to collect the data. The methods described in this chapter collect traffic information from all vehicles using the transport network. Some of this methods can identify the type of vehicles using the network and separate HGVs traffic data. In the case that freight traffic is not identified, Liu, Ge, & Gao (2014) suggest models to estimate freight traffic data using passenger vehicles information.

The traffic data collection methods described next are grouped in two main categories, *in-situ* and *on-board* techniques. The *in-situ* techniques are sensors physically located at pre-specified intervals on the road or along the roadside. *In-situ* techniques are the more mature, experienced, and used technologies. *On-board* techniques refer the collection of real-time



traffic data using probe vehicles (also called probe data). These vehicles provide their location information over the entire road network via mobile phones, GPS, or other sensors. On-board techniques are a new and innovative technology used in Intelligent Transport Systems (ITS). Also the possible combination of techniques is presented as *traffic data collection systems*.

### 3.1.1 In-situ techniques

According to Leduc (2008) and Lopes, Bento, Huang, Antoniou, & Ben-Akiva (2010) these techniques can be divided into two categories, *intrusive methods* and *non-intrusive methods*. The intrusive methods are detectors located on or in the road. The non-intrusive methods are devices physically located along the roads, also called distance measuring instruments. These devices are allocated at predefined distance intervals (checkpoints) and require frequent calibrations to avoid inaccurate readings (Turner, Eisele, Benz, & Holdener, 1998).

#### 3.1.1.1 Intrusive methods

Inside this category are four of the most mature techniques: pneumatic road tubes, piezoelectric sensors, inductive loop detectors, and magnetic sensors.

##### **Pneumatic road tubes.**

Rubber tubes placed across traffic lanes in a specific configuration to detect vehicles (see figure 3-1). Pneumatic tubes are one of the most common methods for collecting speed and volume data. When a pair of wheels (on one axle) hits the tube, air pressure in the compressed tube activates a recording device (counter) that notes the time of the event. The device output raw data are the time stamps of each axle hit. This data is not useful without further reducing it to either basic data (Mcgowen & Sanderson, 2011).

Pneumatic tubes can detect data from several number of lanes (depending on the configuration) and also can be moved to different locations. Two tubes attached to the same counter can be placed a set distance apart in order to determine speed. Speed is obtained by measuring the interval between the time an axle hits the first tube and the time it hits the second tube. Also the direction of the vehicle is detected by recording which tube is contacted first. Based on the pattern of the data, the device matches each compression event to a particular vehicle type according to a pre-defined vehicle classification scheme. Their accuracy is bad for short-time periods, but good for the long-time periods (positive and negative errors cancel each other) (Hamra & Attallah, 2011; Lopes et al., 2010).

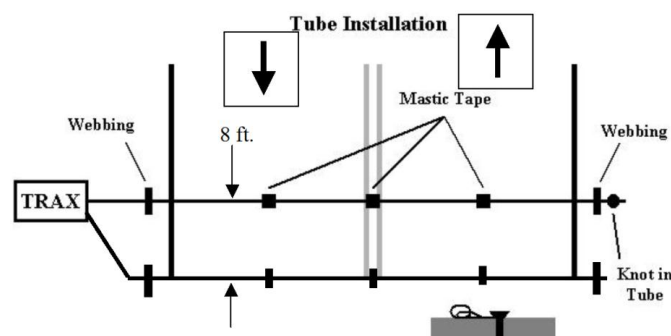

Figure 3-1 Road tube layout (Mcgowen & Sanderson, 2011)

The installation and performance of this method present some disadvantages. Installing the tubes result in temporary disruption of traffic flow. Vehicle classification errors are common, often counts two vehicles as one (with more axles) when they are traveling close together. Roadway geometries can make it difficult to obtain accurate counts using road tubes. Also they require high maintenance, tend to malfunction in certain weather extremes, such as very hot or very cold, and are not efficient for low speed flows (Leduc, 2008).

### **Piezoelectric sensors.**

Sensors with piezoelectric materials that convert mechanical energy into electrical energy. Are placed in a groove along roadway surface of the monitored lanes (see figure 3-2). The traffic data that can be obtained with this sensors includes volume, vehicle classification (axle counts), weight, speed, and traffic density (Hamra & Attallah, 2011; Lopes et al., 2010; Tayahi, Johnson, Holtzman, & Cadet, 2005).

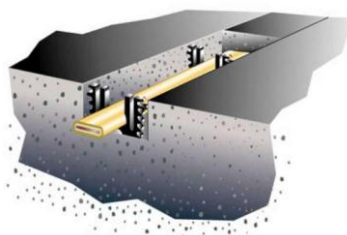

Figure 3-2 Piezoelectric sensor

The main drawback of this mature sensors is a significant number of classification errors due the use of number of axles, axle spacing, and vehicle length. New technology is being researched for their improvement. Golla, Mukherjee, & Harvey (2013) investigate an improvement for vehicles classification by adding the ability to measure the width/footprint of vehicles and identify the tire types.

### **Inductive loop detectors (ILD).**

Inductive loop sensor technology was first introduced for vehicles detection in the early 1960s. After more than 40-year evolution is the most conventional technology used to collect traffic data (widely deployed in Europe over the last decades). This detectors are embedded in the roadways (invisible for drivers) in a square formation that generates a magnetic field. The information is transmitted to a counting device placed on the side of the road (see figure 3-3). This information includes speed, time, vehicle length, density, occupancy, flow, and queue (Bifulco, Galante, Pariota, Russo Spena, & Del Gais, 2014; Gajda, Piwowar, Sroka, Stencil, & Zeglen, 2012; Son, Kweon, & Park, 2011). This sensor can detect and count axles correctly even if axle is lifted, which is the case of un-loaded HGVs.

The main disadvantage of this sensors is the expensive and difficult installation. Requires a significant amount of construction work and closing the traffic road (Ahmed, Hussain, & Saadawi, 1994; Leduc, 2008; Sanwal & Walrand, 1995; Tai, Tseng, Lin, & Song, 2004). Single-loop systems only measure volume and lane occupancy, while dual-loop systems can give speed, vehicle length, and vehicle classification data (Gajda et al., 2012; Jamal, Manaa, Rabee'a, & Khalaf, 2015). ILD are affected by severe weather conditions (snow, freezing, etc.) and by deteriorate pavements (Harlow & Peng, 2001).

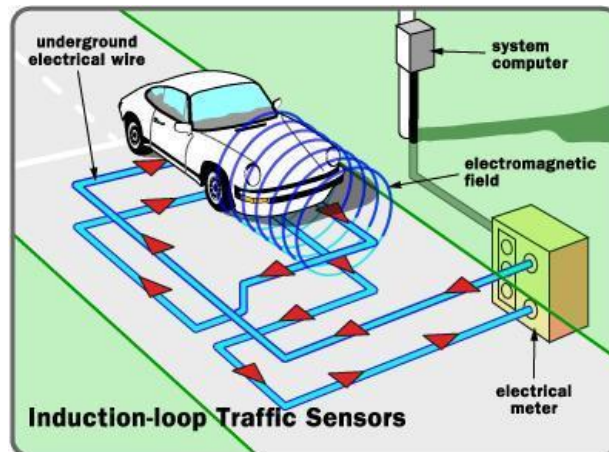

Figure 3-3 Inductive loop detector configuration

### Magnetic sensors

Magnetic sensors detect vehicles by measuring the change in the earth's magnetic field as the vehicles pass over the detector. Magnetic sensors are popular because of their fast and simple installation, usually fixed under or on top of the roadbed (see figure 3-4). In addition to counting vehicles, this sensor also measures the vehicle length which can be used to classify the vehicle, vehicle speeds, pavement wet/dry condition, and travel time. This sensors are also used for vehicle identification, the magnetic field of the vehicle which constitute the vehicle's signature. When installed with a roadside pole-mounted access point, magnetic detectors can provide real-time information by transmitting the data to a server using a wireless service (Kwong et al., 2009; Weil, Wootton, & García-Ortiz, 1998).



Figure 3-4 Magnetic detector NuMetrics NC-97 (Mcgowen & Sanderson, 2011)

#### 3.1.1.2 Non-intrusive methods

Inside this category are the following traffic data collection methods: video cameras, manual counts, infrared sensors, microwave radar, laser radar, acoustic tracking systems, and surveys.

#### Video cameras

Video cameras is the most popular non-intrusive method nowadays. They are able to monitor multiple lanes. Their maintenance easy and cheap, video systems can be reconfigured quickly off the road without lane closure. Are a common technology for license plate recognition (LPR) systems. This systems are useful to monitor driving behavior and identify road violations. The

main drawback of this technology is its sensitiveness to meteorological conditions. Data from video cameras can be obtained manually or automatically. They can detect traffic flow characteristics as volume type, traffic flow, accidents, queues, acceleration, individual vehicles characteristics (e. g. color, shape, length, speed, location, headway distances), turning movements, density, etc. (Bifulco et al., 2014; Vaqar & Basir, 2009).

Video cameras are assisted by advanced image/video processing algorithms that automatically extract real-time traffic information. This combination of hardware and software is also called video image processor. Video image processors present reduced operation and maintenance costs but high initial investment. Image processing finds Intelligent Transport Systems (ITS) applications when integrated for autonomous vehicle guidance (mainly for obstacle detection) (Herrera et al., 2010; Kastrinaki, Zervakis, & Kalaitzakis, 2003). When data is extracted manually, video cameras present a reduced initial investment but high operation and maintenance costs. The video recording quality (distortion, view angle, lighting, etc.) is of high importance for data accuracy for manual data processing (Ding, Banitalebi, Miyaki, & Beigl, 2012; Zheng & Mike, 2012).

*Aerial surveys* are often considered a separate traffic data collection method. In this research they are considered part of the video cameras technique. Aerial surveys refer to airborne vehicles (e.g. airplanes, helicopters, balloons) monitoring traffic flows via camera images and videos (Gentili & Mirchandani, 2012). Information gathered from unmanned aerial vehicles can be used to estimate arterial and freeway traffic characteristics (e.g. congestion) (Bauza & Gozalez, 2013). This method can collect data over long time periods and large geographic areas, including those where data were previously unavailable.

### **Manual counts**

Traffic data collected based on visual examination and judgments of individual observers. The most common equipment used are notebooks, mechanical count boards, and electronic count board systems. Two factors that may affect the quality of manual counts are the quality of counting aids (e.g. mechanical counter, computer program) and the experience of the observer. This method for collecting traffic volumes is very accurate and is considered ground-truth for traffic assessment studies. However, this method present significant errors in vehicle classification. In the findings of Zheng & Mike (2012) the counting errors are usually less than 1% and between 4-5% for vehicle classification. This method require a high degree of effort, thus it typically provide a small sample size (Mcgowen & Sanderson, 2011).

### **Infrared sensors.**

This sensors use infrared energy and are sub-divided in active and passive infrared. Active sensors illuminate detection zones with low-power infrared energy, a portion of the transmitted energy is reflected or scattered by vehicles back toward the sensor (see figure 3-5). Passive sensors do not transmit energy, they detect energy from two sources: 1. Energy emitted from vehicles, road surfaces, and other objects in their field-of-view. 2. Energy emitted by the atmosphere and reflected by vehicles, road surfaces, or other objects. Infrared sensors can obtain volume, vehicle speed, vehicle classification, vehicle length, lane occupancy (Clark, Kidson, & Hodge, 1990; Jamal et al., 2015).

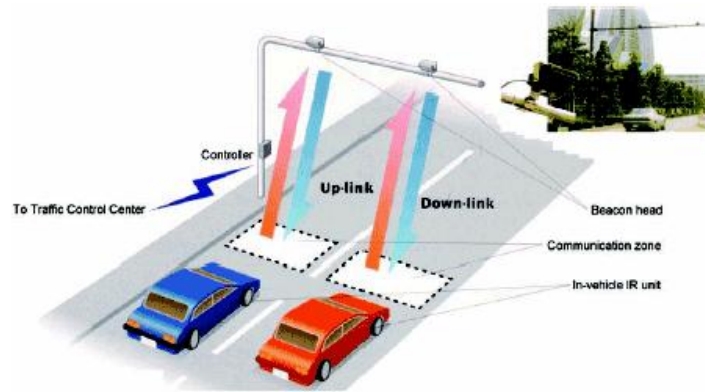

Figure 3-5 Infrared sensor

Some of the advantages of infrared sensors include: high accuracy for vehicle count and classification, good performance during night and under difficult weather conditions, safe, cheap, and easy to install. Both active and passive systems make use of computerized signal processing and correlation techniques to determine data. They can transmit real-time traffic data to road users, therefore are suitable for ITS applications (Ahmed et al., 1994; Tropartz, Horber, & Gruner, 1999)

### Microwave radar.

Also known as radar or Doppler sensor. Was developed for detecting objects in the period before and during World War II. Radar was originally an acronym for Radio Detection And Ranging (Klein, Mills, & Gibson, 2006). This sensor can be seen in figure 3-6. These devices transmit radio waves pulses which bounce off any object in their path and measure the time for the signal to return to the device. The term microwave refers to the wavelength transmitted, usually between 1 and 30 centimeters. This technology collect vehicle counts, speed, direction, lane occupancy, queue length, headway distance and vehicle classification data (Leduc, 2008; Nguyen, Dinh, Le, & Nguyen, 2014).

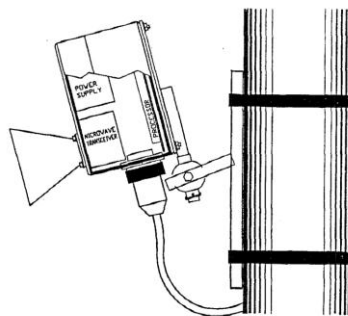

Figure 3-6 Microwave radar (Wang, 1992)

Performs well in extreme temperature exposure (-50°C. +80°C), precipitation conditions, and can be applied in ITS. Park, Pil Hwang, Kim, & Kang (2010) study the use of this sensor for tracking the preceding vehicle. Two drawbacks of this technology are vehicle counts error (5-8%) and the cumulative effects of low level radiation on the driving population. (Wang, 1992; Weil et al., 1998).

### Laser radar

Utilizes a laser beam that returns range and intensity information (see figure 3-7). Law enforcement use manual laser sensors for vehicle speed reading. Laser sensors can also give vehicle classification (length, width, height) (Harlow & Peng, 2001). The main drawback of lasers is that are affected by small particles present in the atmosphere, e.g. snow, dust, and smoke (Weil et al., 1998).

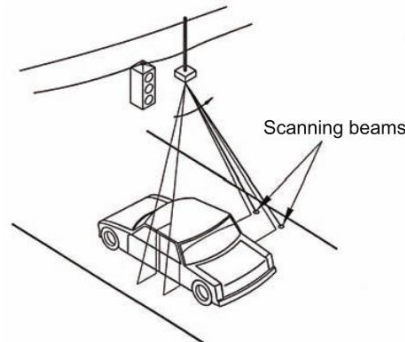

Figure 3-7 Scanning infrared laser radar two-beam pattern across a traffic lane.

### Acoustic tracking systems

Vehicle detection by analyzing acoustic signals of vehicles (Zhenshan, Jianqun, Xuejun, & Guozhong, 2010). Ultrasonic, passive, and sonar are three variants of this method. Ultrasonic sensors available operate by transmitting ultrasonic energy and measuring the energy reflected by the target. Passive acoustic work based only on the reception of sound waves (see figure 3-8). Sonars launch sound pulses and measure their return after being reflected. The acoustic detectors can collect counts, speed, vehicle classification, crash sound events, queue, and lane occupancy for one or more travel lanes (Ntalampiras, 2014).

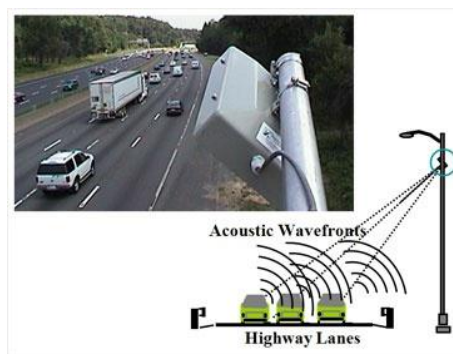

Figure 3-8 Passive acoustic system

Acoustic sensors are not recommended for exact measurements of vehicle flow, velocity and density. And are affected by temperature and wind. Their attractive features are low installation and maintenance costs.

### Surveys

Surveys are a collection of facts and opinions from vehicle users. Traffic data that can be surveyed includes origin-destination (journeys), route choice, travel times, average travel speeds, driving behaviors (safety measures, respect of signals and speed limits), and modes of transportation. Survey method accuracy depend on the sample size and is biased by the



human factor (Ambrosino, Guerra, Pettinelli, & Sousa, 2014; Hong & Goodchild, 2014; Sekimoto, Watanabe, Nakamura, Kanasugi, & Usui, 2013).

There are three main types of surveys: telephone, on-line, and personal surveys. Personal and telephone surveys allow a specific response rate to be calculated. In the on-line surveys a user can take the survey more than one time from different locations biasing the results. The advantage from on-line surveys is that are cheap to perform and can be accessed from any place with internet connection. On-line technology even allows the user to record trip information in the vehicle through a touch-screen interface (Beck, Yan, & Wang, 2009).

### 3.1.2 On-board techniques

On-board electronic devices have are proposed as an alternative traffic data collection infrastructure. This devices usually provide a cost-effective method for collecting traffic data (Herrera et al., 2010). Data are collected by means of a probe vehicle (or instrumented vehicle) and transmitted to a Traffic Control Center (TCC) that determines the traffic conditions. This communication exchange has contributed for the creation of Vehicular Ad Hoc Networks (VANETs). Probe vehicles and VANETs are described next.

#### 3.1.2.1 Probe vehicles

The principle of probe vehicles is to collect real-time traffic data by locating the vehicle over the entire road network via mobile phones, GPS, or other sensors that collect what is called probe data (Bifulco et al., 2014; Leduc, 2008; Vaqar & Basir, 2009). Data such as car location, speed, and direction are collected and sent for its analysis to a TCC. The TCC process the data and send it to the drivers on the road. The processed information include status of traffic and alternative routes suggestions. An example of a probe vehicle system can be observed in figure 3-9. Sanwal & Walrand (1995) name this technologies Intelligent Vehicle Highway Systems.

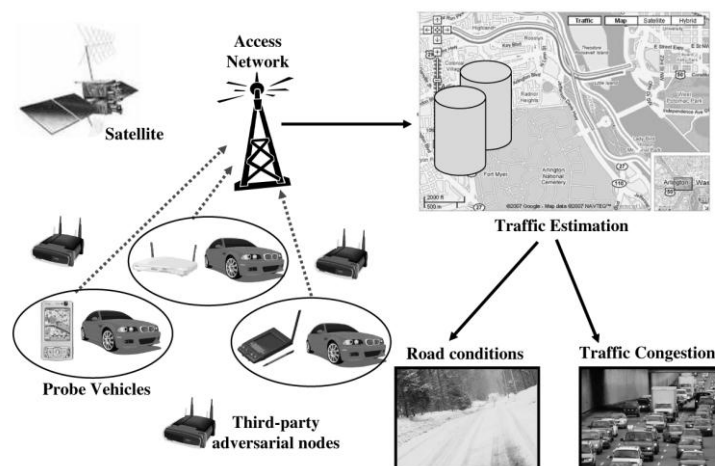

Figure 3-9 Probe vehicle data collection

Data collection from a vehicle moving with traffic means faster data collection, higher data volumes, and more data types (Findley, Cunningham, & Hummer, 2011). Traffic light status is one of the many traffic characteristics that can be estimated using traffic probe data (Zhu, Liu, Li, & Zhang, 2013). This data collection method is related to ITS because of its accurate and real-time traffic data transmission. The accuracy of the obtained data depend on the amount of probe vehicles in the transport network.

In the origins of this technique the probe data was collected manually (moving observer). In this research the moving observer method is grouped in probe vehicles. Nowadays this vehicles are mainly sub-divided in GPS-based, Radio Frequency Identification (RFID) tags, and mobile phones based. Other devices integrated in the probe vehicles are called transponders, because they work as an identifying signal that respond to an interrogating received signal. This four data collection techniques are described next.

#### **Manual probe or moving observer.**

This method involves a vehicle in the traffic stream occupied by a technician acting as an observer. Observers in a test car are required to travel along the road in the direction of the stream considered counting the number of slower vehicles overtaken, the number of faster vehicles that overtake them, and recording their journey time. A run is then made in the opposite direction, counting the number of opposing vehicles met and again recording the journey time. Commonly used for measuring travel time and delay between specified checkpoints. Other examples of traffic data collected from moving observers are road crash data, and roadway geometric elements (Taylor, Woolley, & Zito, 2000; Turner et al., 1998).

This a labor intensive method that could be biased by the driver's behavior and the experience of the observer. Checkpoints are commonly missed and specific capacitation for the technician is need. The moving observer can use complementary equipment such as: video cameras, laser scanners, global positioning systems, etc. (Findley et al., 2011).

#### **Mobile-based probes**

In this method the mobile phone positioning is regularly transmitted to the TCC by means of cell tower signal triangulation or by other techniques (3G, GSM). The vehicle location is then converted into useful information (e.g. direction and velocity). The challenge in using cell tower information for estimating position and motion of vehicles are the significant difficulties for an accurate estimation of vehicle speed (Gongjun, Olariu, & Popescu, 2012; Herrera et al., 2010). The data obtained from mobile-based probe vehicles are called Floating Car Data (FCD). FCD is commonly used in VANETs.

The high penetration of mobile phones in the driving population make them attractive traffic sensors. This technology is less expensive than conventional detectors. Hardware in vehicles or infrastructure along the road is not necessary. This probes are fast and easy to install, need low maintenance, and have large coverage capabilities. Mobile-based probes can be combined with the GPS-probes as demonstrated by Herrera et al. (2010) in 'The Mobile Century field experiment'. Sophisticated algorithms are required to extract and process the high amount of data (Big Data) before sending it back to end-users.

A variant of this category of probe vehicles is the new technique of *using the power of crowd* or what is called *participatory sensing method*. Participatory sensing propose traffic data exchanging through social network. Vehicle passengers use their smart phone to report incidents, give instant route information, or their feedback about the infrastructure and congestion status (Farkas, Nagy, Tomás, & Szabó, 2014). Is considered a viable and cost effective alternative to collect and share traffic data (Harris, Wang, & Wang, 2015). Social networks such as Twitter, LinkedIn, Facebook, and Google+ have been one of the biggest technological booms of this decade. Researchers as Szabo et al. (2013), Raphiphan, Zaslavsky,



& Indrawan-Santiago (2014) and Zimmermann, Wirtz, Puñal, & Wehrle (2014) investigated the feasibility of this social networks as traffic data providers.

### GPS-based probes

This category of probe vehicles obtain position and instantaneous velocity readings with a high accuracy. GPS-based probes can provide time-tagged data (per second) on position, speed, distance travelled, acceleration, fuel consumption, and engine performance (Taylor et al., 2000). Is used as a source of real-time information by many TCCs. One of the biggest advantages of this technology is the compatibility with Geographical Information System (GIS) software (Turner et al., 1998). According to Herrera et al. (2010) the main drawback of this technology is its low penetration in the population. However, GPS are already common for freight logistic companies tracking HGVs and their cargo. Is possible to use GPS technology in dedicated fleets of vehicles to monitor specific traffic sectors for example HGVs, taxis, buses or private vehicles (Gentili & Mirchandani, 2012).

### Radio-frequency identification (RFID).

RFID is the wireless use of electromagnetic fields for the purposes of automatically identifying tracking tags (transponders) attached to probe vehicles. Readers located on the side of the road keep record of vehicles' tags through radio frequency (RF) signals (see figure 3-10). This method is used to obtain individual travel times, time stamps, traffic density, O/D, traffic flow, and vehicular location. RFID probes have ITS and Automatic Vehicle Identification (AVI) applications as exemplified by Wen (2010) and Wu & Yang (2013). Some disadvantages of this system are the high installation costs and its limited coverage (Ding et al., 2012)

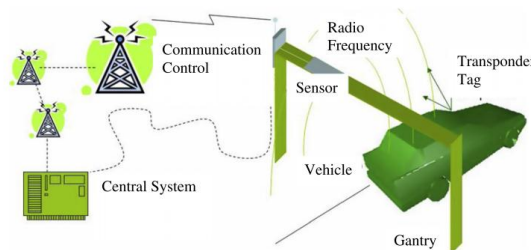

Figure 2 Complete RFID system connection [2].

Figure 3-10 RFID system (Hamra & Attallah 2011)

#### 3.1.2.2 Vehicular Ad Hoc Networks (VANETs)

VANETs are cooperative vehicular systems where probe vehicles act as nodes in the network. This networks work through the wireless exchange of information between vehicles (V2V) and between vehicles and infrastructure (V2I, I2V) (Bauza & Gozalvez, 2013; Thajchayapong, Garcia-Trevino, & Barria, 2013).

The differences between this communication methods are that I2V concepts send information from the TCC to the instrumented vehicle. V2I collect and provide data to the TCC through probe vehicles. And V2V provide data to the network without requiring a traditional TCC. V2V transmits data to and from other vehicles using wireless communications. V2I and I2V can work together with traditional in-situ data collection techniques (Boskovich & Barth, 2013) (Sanwal & Walrand, 1995).

VANETs are currently being used in the design of innovative ITS solutions for road traffic management. The overload of information due the high amount of data collected is the main inconvenient of this networks. Placzek (2012) propose them as a tool for optimal route selection in urban network and traffic information sharing to address the problem of vehicle traffic congestion.

### 3.1.3 Traffic data collection systems

Traffic collection systems are the combination of the different traffic in-situ and on-board techniques. This systems are used when a single method is not enough to collect the needed information. Examples of different methods combinations are presented in table 3.1.

Automatic Vehicle Identification (AVI) and Weight in Motion (WIM) are the most popular traffic data collection systems. Both systems are particularly attractive for obtaining freight specific data.

Table 3.1 Examples of data collection methods combinations

Combined methods	Function	Reference
Video, sonar and microwave	Measure the flows of all incoming and outgoing links of the intersection node.	(Gentili & Mirchandani, 2012)
Magnetic and Acoustic	Magnetic sensors embedded in the road to count vehicles and acoustic sensors located at the road side for speed and queue detection.	(Barbagli et al., 2010)
Piezoelectric sensors and ILD	Vehicle classification. ILD and piezoelectric sensor arrays to determine axle spacing and axle count of individual vehicles.	(Golla et al., 2013)
Acoustic and ILD	The sonic sensor mounted above the road for vehicle speed. ILD for vehicle counts and queue length	(Weil et al., 1998)
Video and ILD	For incident detection applications. ILD is complemented with strategically placed surveillance cameras used to confirm the existence of an incident and assess its severity.	(Weil et al., 1998)
Infrared and Acoustic	For vehicle classification. A traffic sensor node consisted in six passive infrared sensors and one ultrasonic connected to a controller.	(Warriach & Claudel, 2013)
Laser, camera, RFID	Toll plaza vehicle classification and identification	(Tropartz et al., 1999)
Infrared and RFID	Traffic data to trace criminal or illegal vehicles (stolen cars or vehicles that evade tickets, tolls or vehicle taxes). A RFID reader, a passive tag, a personal computer, a pair of infrared sensors, and a high-speed server with a database system.	(Wen, 2010)

#### Automatic Vehicle Identification (AVI)

AVI systems are based on the use of on-board sensors, in-situ technologies, communications network, and a central computer system (Quiroga, 2000). The type of on-board sensors used depend on the objective of the study. GPS is useful as tracking tool, RFID tags are used for road tolls, congestion pricing, and traffic contraventions detection. AVI can be used for traffic management, route improvement, and to trace criminal or illegal vehicles such as stolen cars or vehicles that evade tickets, tolls or vehicle taxes (Wen, 2010).

AVI techniques are useful applications for the logistics sector because they identify, monitor, track and collect data on HGVs movements and cargo, provide trip rates, congestion pricing, road tolls, and detect traffic violations. AVI systems are compatible with GIS and internet,

disseminating real-time geo-referenced travel time and speed data to the traveling public. This systems have been tested in the United States and Dubai, and proven to be efficient, highly accurate, and to have an attractive benefit/cost ratio (Hamra & Attallah, 2011).

**Weight in Motion (WIM) systems**

WIM systems can employ various types of sensors including the WIM station, a fixed counting device (ILD, camera, etc.), and a communication system. If no communication infrastructure exists, WIM systems can save the data to later retrieve it. WIM devices are designed to capture and record axle weights and gross vehicle weights as vehicles drive over a measurement site. Unlike static scales, WIM systems are capable of measuring vehicles traveling at a reduced or normal traffic speed and do not require the vehicle to stop.

The usefulness of this method for freight traffic is related to the control of the overloaded HGVs. Before WIM systems, this control was made randomly and the vehicles were stopped and weighed on parking areas, being an inefficient method that contributed to congestion. Is because of this that the French Ministry of Transport proposed a WIM system connected to a national database to control overloaded HGVs. The system used piezoelectric sensors, ILD, and video cameras with infrared light and LPR technology (Stanczyk & Klein, 2012).

**3.1.4 Overview of traffic collection methods**

In this section a detailed description of fifteen data collection methods is presented. Eleven of those methods are in-situ techniques and the rest are on-board techniques (probe vehicles). The traffic data collection systems are also presented including the popular AVI and WIM systems. Tables 3.2 and 3.3 present a summary of the perception of the author of this thesis regarding the general pros and cons of both techniques.

The knowledge about the methods to collect data opens a new focus on this literature review: identifying the necessary traffic data for analyzing the urban freight transport sector problems. Next section describes the relationship between the different traffic data that can be collected with in-situ and on-board techniques and the urban development sectors where freight traffic can have an impact.

Table 3.2 Pros and cons from In-situ techniques

<b>Pros</b>	<b>Cons</b>
High experience, potential and quality	High amount of devices must be deployed (limited coverage)
Mature technologies	Expensive to install and maintain
Accurate traffic volumes	Low travel time and location accuracy (only point location and time stamps).
Fixed counting stations provide a baseline for traffic data collection	Low precision for urban areas (traffic interruptions, etc.)
	Need extra add-ons for transmitting real-time traffic data
	Sometimes non-intrusive detectors checkpoints are not properly geo-referenced (GIS)

Table 3.3 Pros and cons from on-board techniques

<i>Pros</i>	<i>Cons</i>
Real-time traffic data monitoring (ITS)	New technologies (further research needed)
Many different traffic data can be collected	The usefulness of the collected data depends on the data processing algorithms from the TCC
No need for infrastructure along the roads	Data quality depends on the amount of probe vehicles in the network.
Accurate vehicle speed and location	Low accuracy for traffic volumes.
GPS-based and Mobile-based probes can be combined	
Large coverage	

### 3.2 Freight traffic data and urban development

A crucial component of a freight transport management system is freight traffic data. Data are essential in helping public and private sector decision-makers ensure that urban freight transport is efficient and sustainable. It provides understanding of freight operations, forecasts urban freight models, and monitors the effects of policy measures. (Neirotti, De Marco, Cagliano, Mangano, & Scorrano, 2014; Schilk & Seemann, 2012).

Freight traffic efficiency generate benefits in the urban transport and logistics sectors. Therefore, is necessary to understand the urban sectors influenced by freight transport. Then, sustainable and smart solutions can be applied to the different needs and interests of each sector. This section introduces the different type of traffic data and the urban sectors where data has influence.

#### 3.2.1 Traffic Data

The literature review targets freight traffic data that can be applied in national (The Netherlands) and regional (Europe) objectives. Different traffic studies present different type of traffic data that can be used for decision-making. Table 3.4 present a summary of some traffic data variables used in general traffic studies. Table 3.5 present traffic data variables used in freight traffic studies. A brief definition of the relevant traffic data is presented next.

**Accidents.** Incidental and unplanned events in the transport network.

**Delay.** A period of time by which the total travel time is affected and postponed.

**Driving behavior.** A subjective traffic characteristic that reflects the way in which drivers act.

**Noise level.** The sound waves emanating from motor vehicles.

**Number of journeys.** The amount of times a vehicle travel from one place to another. Also known as *vehicle trips*.

**Queue length.** The length covered by a line or sequence of vehicles awaiting their turn to proceed on their route.

**Road condition.** The state of the road surface.

**Traffic density.** The number of vehicles per unit length of the roadway.

**Traffic flow.** Rate at which vehicles transit certain point of the road network (vehicles/hour).

**Traffic volume.** The amount of vehicles in a specific road segment or in the entire network. The common source for this information are traffic counts.

**Travel direction.** The course along which vehicles moves. In road traffic is given by the road lane way.

**Travel time.** Duration of each travel journey.

**Traveled distance.** Length of journey measured in Vehicle Kilometers Traveled (VKT).

**Vehicle classification.** Vehicles are categorized depending on characteristics such as: number of wheels, number of axles, length, weight, etc. In Europe, the classifications for vehicle category are based in the United Nations Economic Commission for Europe (UNECE) standards (see appendix 1).

**Vehicle identification.** To recognize unique features of a vehicle as an individual element of the transport network.

**Vehicle location.** The particular place or position occupied by the vehicle.

**Vehicle speed.** The rate at which vehicles move (km/hr).

**Vehicle weight.** The heaviness of the vehicle.

This traffic data are general for passenger and freight traffic. But some traffic data is of particular interest for freight transport. Five of this data are presented by Maia & do Couto (2013). They calculate the generalized transportation costs for the freight sector by relating costs to road segment length, average speed, cargo capacity of vehicles, distance costs (fuel consumption, operator, etc.), and travel time.

Another important data for the freight sector is travel journeys, according to Cherrett et al. (2012) this data provide an improved understanding of urban freight activity. The amount of journeys is related to freight deliveries efficiency. Flow, weight, speed, time, and number of axles are described, by Stanczyk & Klein (2012), as important HGVs features to calculate the damage caused on the road and the most overloaded days and hours.

Table 3.4 Traffic data - literature review

Reference	Volume	Time	Distance	Flow	Speed	Density	Delays	Location	Direction	Journeys	Incidents	Road condition	Driving behav.	Vehicle info.
(Županović et al., 2008)	x			x								x		
(Leduc, 2008)	x		x	x	x			x	x	x		x		x
(Taylor et al., 2000)		x	x	x	x		x	x						x
(Raphiphan et al., 2014)		x				x		x		x	x		x	
(Quiroga, 2000)		x		x	x	x	x	x				x		x
(Son et al., 2011)	x	x		x	x						x			
(Wang et al., 2011)		x		x	x	x			x		x	x	x	
(Syed et al., 2014)		x	x	x						x				x
(Hull, 2005)	x		x	x						x				
(Baldasano et al., 2010)					x							x		
(Zhu et al., 2013)					x			x	x					
(Bauza & Gozalvez, 2013)		x		x		x		x				x		
(Geng & Cassandras, 2012)					x			x		x			x	
(Zimmermann et al., 2014)								x						
(Pirrera et al., 2014)	x													
(Bifulco et al., 2014)													x	
(Sanwal & Walrand, 1995)		x		x	x			x		x	x		x	
(Eichler & Daganzo, 2006)		x		x	x	x	x	x	x					x

Table 3.5 Freight traffic data - literature review

Reference	Volume	Time	Distance	Flow	Speed	Density	Delays	Location	Direction	Journeys	Incidents	Road condition	Driving behav.	Vehicle info.
(Kassomenos et al., 2006)	x		x	x	x									x
(Zhang et al., 2012)		x		x	x			x				x		x
(Berkowicz et al., 2006)	x				x							x		x
(Browne et al., 2012)	x		x	x						x	x			x
(Kumar et al., 2014)	x		x	x	x	x								x
(Liu et al., 2014)	x	x	x		x									x
(Thajchayapong et al., 2013)		x		x	x			x			x			
(Moriarty & Honnery, 2013)		x	x		x									
(Hong & Goodchild, 2014)		x	x		x	x						x		x
(Borrego et al., 2000)	x				x							x		x
(Gongjun et al., 2012)		x	x	x	x	x	x	x			x	x		x
(Pandian et al., 2009)	x	x	x	x	x	x	x				x	x	x	x
(Schilk & Seemann, 2012)				x							x			
(Herrera et al., 2010)	x	x	x	x	x	x		x	x		x			
(Fujiwara & Zhang, 2013)	x	x	x	x	x			x			x	x	x	x
(Stanczyk & Klein, 2012)	x				x									x
(Cherrett et al., 2012)										x				

### 3.2.2 Freight traffic data and urban transport development

Freight traffic activity is a component of the urban transport network. Freight traffic data plays an important role in urban transport development. Authorities aim for an economic, social, and environmental sustainable transport network. Therefore, authorities should monitor freight activity for the development, implementation, and management of different transport plans and programs.

Performance measures are proposed by Kaparias et al. (2012) and Russo & Comi (2011) to review the impact of freight traffic in the urban transport development. They categorize these measures in traffic efficiency, traffic safety, pollution reduction, social integration, and land use. Similar to those measures, this research categorizes urban transport development in four main sectors: environment, innovation, infrastructure, and policy-making. This classification takes into account the economic, social, and environmental impacts of freight transport systems.

In the following paragraphs, the impact of freight traffic in these four sectors is described. Also, some of the traffic data related to each sector is identified. For a more detailed relation between traffic data and the urban transport development sectors, see appendix 2 and appendix 3.

#### 3.2.2.1 Urban environment

This section describes the impact of freight traffic in locations with high human population density and vast human-built features. Urban areas may be cities, towns, or conurbations. The classification by Browne et al. (2012) of urban environment sectors affected by freight traffic is adopted (congestion, pollution, and safety).

**Congestion.** The increasing amount of HGVs in urban areas contribute to urban congestion. Two features of the HGVs that directly affect congestion are their low operation speeds and the drop-off of goods in some locations with no sufficient space for parking. Congestion normally results in: slower speeds, time delays, increased fuel consumption, pollution, stress, health hazards, and vehicular queueing. Therefore, it is important to monitor the level of congestion. Researchers have proposed different congestion indicators some of them are vehicles density, traffic incidents, volume to capacity ratio, and intersection delay (Quiroga, 2000; Raphiphan et al., 2014).

**Pollution.** Researchers generally analyze the impact of traffic in pollution using different vehicles categories. The freight traffic contaminants into the natural environment can be grouped in air and noise pollution.

- Air pollution and emissions. Passenger and freight transport are responsible for nearly a quarter of GHG emissions and major pollutants: CO, Benzene, HC, NO<sub>x</sub>, PM<sub>10</sub> and VOCs) (Kassomenos, Karakitsios, & Papaloukas, 2006). Freight traffic normally results in a higher amount of pollution than passenger cars (Baldasano, Gonçalves, Soret, & Jiménez-Guerrero, 2010). This due the type of engines from the HGVs (diesel fuel). Air pollution is measured calculating the traffic emissions per vehicle. There is no freight traffic data that directly indicate the impact of HGVs on air pollution. To read more about how to calculate this emissions see appendix 4 (Berkowicz, Winther, & Ketzler, 2006; Borrego, Tchepel, Barros, & Miranda, 2000; Smit, Ntziachristos, & Boulter, 2010).
- Noise disturbance. Vehicular traffic noise from highways and roads create problems for surrounding areas. Especially with high traffic volumes and speeds. Pirrera et al. (2014) categorized transportation noise during the night as the most disturbing factor for sleep and recuperation in humans. Similar to air pollution, HGVs engine generally noisier than the engine from passenger vehicles. Kumar, Nigam, & Kumar (2014) calculate noise disturbance using vehicle volume/hour and average vehicle speed instead of capturing noise levels.

### **Traffic safety**

The level of safety of certain road or highway can be generally measured using the number of accidents (Kaparias et al., 2012). In the freight sector, also parking facilities and monitoring HGVs cargo are important for traffic safety. Many different models to predict and avoid accidents using real-time traffic data have been investigated (see appendix 5) (Golla et al., 2013; Marchesini & Weijermars, 2010; Son et al., 2011; Thajchayapong et al., 2013; Villanueva, Albusac, Jimenez, Villa, & Lopez, 2013; Wang et al., 2011; Zhang, Yao, Qiu, Peng, & Zhang, 2012).

#### **3.2.2.2 Technology innovation**

Technology revolutionizes the way urban infrastructures and services are designed, developed, delivered and accessed. Nowadays, when talking about sustainable urban planning, is common to think about smart solutions (Roscia, Michela, & Lazaroiu, 2013). Smart solutions are part of the Smart City concept: an integration of sub-systems driven by Information and Communication Technology (ICT) systems. Nowadays authorities and organizations pay increasing interest to ICT and ITS to achieve higher freight traffic efficiency



(Sternberg & Andersson, 2014). The introduction of smart technologies to manage urban transport systems is a promising strategy for improving efficiency and quality in freight transport (Debnath et al., 2014).

Advanced solutions for mobility management can return useful data to authorities e.g. traffic on routes, accidents occurrence, queue detection etc. This information can assist travelers in their decisions on route choice. Freight traffic route choice is affected by different objectives and motives than passenger traffic. Researchers have studied the selection of origin-destination routes in freight traffic (Arentze, Feng, Timmermans, & Robroeks, 2012; Feng, Arentze, & Timmermans, 2013; Maia & do Couto, 2013).

Harris et al. (2015) present a review of existing and emerging ICT applications in the field of freight transport for achieving efficient road freight operations in Europe (see table 3.6). Other ICT applications in freight transport include supply chain planning and management systems, vehicle tracking systems, and fuel recording systems (Barbagli, Manes, Manes, Langer, & Bacchi, 2010; Russo & Comi, 2010). To read about the barriers of adoption for ICT and traffic data collection methods considered ICT see appendix 6. ITS applications in freight traffic include: exchange of information among actors, vehicle routing and scheduling, efficient loading/unloading. Table 3.7 lists some examples of ITS applications around the world.

### 3.2.2.3 Infrastructure

Sustainability in the logistics sector depends on the efficient use of infrastructure and resources. Authorities must deal with the complexity of the legacies of past infrastructure. This are infrastructure design, installation, operation, and upgrades (Gann, Dodgson, & Bhardwaj, 2011). This section describes three main elements of urban transport infrastructure: roads, intersections, and parking.

**Roads and intersections.** Geometries of this infrastructures should be able to satisfy the HGVs requirements. This requirements are: measurements for to make turns, height under bridges, pavement conditions, special lanes, etc. (Golla et al., 2013). Studies reveal that building and expanding infrastructure increase rather than decrease problems (Lozano, Granados, & Guzmán, 2014; Santos, Behrendt, & Teytelboym, 2010)

**Parking facilities.** According to Carrese et al. (2011), the number of existing and planned infrastructures is far to be capable of satisfying the HGVs parking demand. The insufficiency of parking facilities brings congestion, pollution, and improper occupancy of other highway spaces, due to the search for parking spaces by truck drivers. This problem is also related to the reduction of security and safety in the road transport network due to attacks on high value cargo and vehicles. The European Commission is responding to the lack of adequate parking facilities for HGVs through the Secure European Truck Parking Operational Services (SETPOS) project.



## Monitoring the traffic network: Freight traffic data collection

Table 3.6. 33 European ICT development initiatives (Herrera et al., 2010)

ICT Application	Potential benefits	#	Exemplar EU FP projects
Freight resource management systems and applications	<ul style="list-style-type: none"> <li>•Improved operational efficiency.</li> <li>•Reduced empty runs through better route planning.</li> <li>•Improved utilization of transport infrastructure.</li> <li>•Improved customer satisfaction.</li> <li>•Reduced overall costs due to vehicle optimization.</li> </ul>	1	Intra-company resource management system
		2	Integrated route planning with mobile communication
		3	Information exchange and freight resource management in multimodal transport
		4	Telematics and software system to support expanding national and trans-European traffic planning needs
		5	Automatic, optimal and intelligent warehouse, and (un)loading system for small inland vessels
		6	Telematics system for rail car asset management
		7	Maritime navigation and information services: port traffic management, maritime operation services and maritime information management
Terminal & Port information and communication systems and applications	<ul style="list-style-type: none"> <li>•Reduced loading and unloading time at intermodal terminal due advanced terminal operation systems.</li> <li>•Improved utilization of intermodal terminal infrastructure.</li> <li>•Improved, efficient interfaces between different modes at transshipment points for achieving seamless transfer of cargo.</li> <li>•Reduced operation costs.</li> <li>•Improved customer service and satisfaction.</li> </ul>	8	Cargo pre-notification system, Container identification & location system and Ferry reservation system
		9	Automatic Equipment Identification for monitoring load units, vehicle and staff
		10	Logistics Information & Communication System for intermodal cargo terminals
		11	Information exchange between road freight transport and freight center operators
		12	ICT tools and services for easing the mandatory data supply and data delivery to improve the integration of ports into intermodal transport chains
		13	Container Handling in Intermodal Nodes
		14	Integrated ICT tools to support logistic and business operations in the port and dry port areas
		15	Fully automated system for the distributed intermodal transport and for processing full trains in port to dry-port
Freight and Fleet tracking and management systems and applications	<ul style="list-style-type: none"> <li>•Enabling operators to monitor and manage the cargo and vehicle, as well as obtain up-to-date information.</li> <li>•Improved utilization of intermodal terminal infrastructure.</li> <li>•Improved customer service through better communication and providing sufficient and real-time information regarding cargo and shipment</li> <li>• Improved security and safety procedures</li> <li>• Shorter lead time, inventory reduction</li> </ul>	16	Intermodal Fleet and Cargo-Monitoring System
		17	Cargo Supervision System
		18	Tracking and tracing services
		19	Integrated and global management system for door-to-door intermodal transport operations: transport chain monitoring system and freight transport monitoring systems
		20	Integrated end-to-end system: goods tracking & tracing, freight identification, efficient transshipment at terminals and node, monitoring the transport of hazardous and perishable goods
		21	Intelligent cargo infrastructure
		22	Intermodal global door-to-door container supply chain visibility
		23	Global container chain management
		24	Container security through visibility
Integrated operational/information exchange Platform/Portal/Marketplace	<ul style="list-style-type: none"> <li>•Electronic one-stop-shop marketplace for all parties along the multimodal chain, enabling them to provide bespoke services and accelerate data and information exchange between the participants</li> <li>• Allow the related authorities (e.g. customs and port authority) to interact with the operators and exchange information and transport-related documentation</li> </ul>	25	E-commerce system: booking, scheduling, negotiation, brokerage, payment and invoicing data; connect intermodal users in short-sea-shipping
		26	Integration of intelligent traffic management systems with the freight transport management systems operation, including intermodal freight transport
		27	Integrated logistic networks and operational platform with inland navigation
		28	Integrated Operational Platform accessible to the Small and Medium players
		29	European Intelligent Transport System Framework Architecture
		30	Generic system architecture for intermodal transport bringing together transport management, traffic and infrastructure management and administration
		31	Roadmap of an integrated many-to-many e-logistics system in Europe
		32	e-Freight Framework to facilitate paperless information exchange among all EU freight transport stakeholders
		33	Support new intermodal logistics services: synchronize vehicle movements and logistics operations; adapt to changes through an intelligent cargo concept and develop an open freight management ecosystem

Table 3.7 ITS examples

ITS	Project characteristics	Data used	Reference
<b>Advanced Driver Assistance Systems (ADAS)</b>	Freight control logics, opportunity to improve road safety and support efficient transportation systems. This system influence the interaction among vehicles and thus affect traffic flows and characteristics, and also control the driving task directly (reducing drivers' errors and shortening reaction times).	Driving behavior. Data that represents the interaction between the single components of a traffic stream (spacing with respect to the vehicle(s) ahead, lane changing).	(Bifulco et al., 2014)
<b>RENAISSANCE</b>	Real-time freeway network traffic surveillance. Major tasks: - Traffic state estimation & prediction - Travel time prediction - Incident alarm	Based on macroscopic traffic flow modeling.	(Wang et al., 2011)
<b>River Information Services (RIS)</b>	eFreight (Internet for cargo) designed to optimize real-time exchange of traffic data between water and shore contributing to a more efficient transport processes in inland navigation.	Tactical traffic information (the present vehicle characteristics and movements) and strategic traffic information (analysis of future traffic situations).	(Schilk & Seemann, 2012)
<b>Cooperative traffic congestion detection (CoTEC)</b>	Road traffic management and safety via efficient detection of road traffic congestion using V2V communications.	Road traffic conditions: using vehicles position & speed.	(Bauza & Gozalvez, 2013)
<b>Vehicular Network Rerouting Autonomy</b>	Traffic efficiency, re-routing vehicles using V2V, I2V, and V2I communication	Traffic data from Traffic Management Center (TMC).	(Boskovich & Barth, 2013)
<b>NOTICE</b>	A secure and privacy-aware architecture for the notification of traffic incidents. Using I2V and V2V communication. The infrastructure has the responsibility for traffic information dissemination decision-making	Speed, acceleration/deceleration, location, time, lane changes. In addition: engine sensors, assemblies, gas tank sensors, tire pressure sensors, and sensors for outside temperature.	(Gongjun et al., 2012) & (Thajchayapong et al., 2013)
<b>Vehicular Ad-hoc Networks (VANET)</b>	Notification of traffic events. Using V2V and V2I communications.	Traffic flow data, Individual-vehicle data.	(Gongjun et al., 2012) & (Thajchayapong et al., 2013)
<b>VGrid and WILLWARN</b>	Anomaly detection	Microscopic traffic data (e.g. wheel speed, reduced friction, queue length).	(Thajchayapong et al., 2013)
<b>Mobile Ad-hoc networks (MANET)</b>	Identify different road traffic conditions	Traffic flow data.	(Vaqr & Basir, 2009)
<b>MIDAS</b>	Motorway Incident Detection and Automatic Signaling (Loop detectors)	Traffic data from a network of traffic sensors.	(Bifulco et al., 2014)
<b>POVA</b>	Traffic light sensing system. Traffic management, traffic light optimization, and real-time vehicle navigation	Vehicle position and speed traffic data.	(Zhu et al., 2013)

### 3.2.2.4 Policy related data

Policies and regulations target the improvement of social, environmental, and economic impacts of urban freight transport. With the right policies authorities could tackle problems as traffic congestion, air pollution, noise disturbance, and safety (Neirotti et al., 2014). In some European countries legislations regarding freight transport have already been set up. United Kingdom introduced the Traffic Management Act 2004 to tackle congestion and disruption problem on road networks. There are many examples in the literature about policies in The Netherlands (see table 3.8) and Europe (see table 3.9).

Three of the most common measures to improve freight flows in urban areas were identified by Russo & Comi (2010). The measures are HGV access and loading approaches in urban areas, last mile solutions, and urban consolidation centers. Efficient use of infrastructure, technology, access and loading help to reduce the environmental impact of the freight transport sector.

According to Nuzzolo & Comi (2014) and Russo & Comi (2010), the four main actors in urban freight transport system are: end consumers, retailers, wholesalers, and carriers. A critical factor in the success of each city to find an optimal solution to its problems though policy-making, is the analysis and consideration of the interests of all the actors involved. A lack of coordination can risk the achievement of policy objectives, therefore the need for integrated policies (Santos et al., 2010). The coordination could be horizontal (between local authority departments and service providers) or by vertical (local to national government) (Hull, 2005).

Table 3.8 Traffic policies and regulations in The Netherlands

Policy	Benefits	Reference
<b>Low emission zones - Amsterdam</b>	Reduce air pollution and emissions	(Boogaard et al., 2012)
<b>Low emission zone &amp; Traffic circulation plan - The Hague</b>	Reduce air pollution and emissions	(Boogaard et al., 2012)
<b>Low emission zones &amp; User restrictions - Den Bosch</b>	Reduce air pollution and emissions	(Boogaard et al., 2012)
<b>Low emission zone - Tilburg</b>	Reduce air pollution and emissions	(Boogaard et al., 2012)
<b>Low emission zones - Utrecht</b>	Reduce air pollution and emissions	(Boogaard et al., 2012)
<b>Low emission zones - Utrecht</b>	Reduce air pollution and emissions	(Browne et al., 2012)
<b>Consolidation centers</b>	Improved city logistics services	(Browne et al., 2012)
<b>Alternative vehicle use</b>	Reduce noise, air pollution, and emissions	(Browne et al., 2012)
<b>Alternative vehicle use - Utrecht</b>	Reduce noise, air pollution, and emissions	(Leonardi et al., 2014)
<b>Alternative vehicle use - Amsterdam</b>	VKT reduction	(Lopez-ruiz et al., 2013)
<b>Incentives to walking and cycling</b>	positive effects on health, environment, and the economy	(Santos et al., 2010)
<b>Teleworking experiment 1990 - The Hague</b>	Decrease in the number of trips	(Santos et al., 2010)
<b>Eco-driving lessons 2001</b>	Fuel-efficient driving style.	(Santos et al., 2010)

Monitoring the traffic network: Freight traffic data collection

Table 3.9 Traffic management policies examples

Sector	Policy/Regulation	Benefits	Reference
General Traffic	<b>Unique optimal speed circulation - Barcelona</b>	Reduces: pollutants emissions, congestion, noise, and accidents; based on DAT.	(Baldasano et al., 2010)
	<b>Replacing a signalized intersection with roundabout - Sweden</b>	Reduction of 29% in the CO emissions, 21% in the NOx, and 28% in fuel per car.	(Várhelyi, 2002)
	<b>Eco-driving campaigns</b>	Drive in a fuel-efficient and environmentally friendly way. CO2 emissions -10 per cent.	(Santos et al., 2010)
	<b>Speed limit enforcement - U.K.</b>	Significant effects on both emissions and road safety, which can also bring more fuel-efficient driving.	(Santos et al., 2010)
	<b>High-occupancy vehicle (HOV) lanes</b>	Traffic flow improvements	(Quiroga, 2000)
	<b>Preferential parking for HOVs</b>	Parking management	(Quiroga, 2000)
	<b>Remote parking with shuttle service</b>	Parking management	(Quiroga, 2000)
	<b>Traffic signal optimization</b>	Traffic flow improvements	(Quiroga, 2000)
	<b>Incident Management systems</b>	Traffic flow improvements	(Quiroga, 2000)
	<b>Change of flow direction, reversible roads, and access restrictions.</b>	Traffic flow improvements	(Lozano et al., 2014)
	<b>Bicycle and pedestrian programs</b>	Traffic flow improvements	(Quiroga, 2000)
	<b>Road-pricing</b>	Targeting to regulate passenger traffic	(Russo & Comi, 2010)
	<b>London Congestion Charging Scheme</b>	Traffic flow improvements	(Browne et al., 2012)
	<b>On street loading spaces (Parking)</b>	Total vehicle kms / journeys by road in urban area	(Browne et al., 2012)
<b>Road user charging - U.K.</b>	Reduce road traffic	(Hull, 2005)	
Freight Traffic	<b>Vehicle use restrictions</b>	Route diversion, no-drive tracks, truck movement control	(Quiroga, 2000)
	<b>Teleworking and teleshopping - U.K.</b>	Reduce congestion and also CO2 emissions. Improved logistics: reduction of transport costs and delivery times.	(Santos et al., 2010)
	<b>Limited Traffic Zone (LTZ) freight</b>	Freight vehicle access and parking is subject to time windows in the inner area termed "LTZ freight" (e.g. Rome, Barcelona, Dublin).	(Russo & Comi, 2010)
	<b>Loading and unloading zones</b>	Dedicated zones for handling freight (e.g. Rome zone quipped with ICT)	(Russo & Comi, 2010)
	<b>Freight Operator Recognition Scheme (FORS)</b>	Improving driver behavior, vehicle and fleet management, and safety and efficiency in transport operations.	(Browne et al., 2012)
	<b>Delivery and Servicing Plans (DSPs) - London</b>	Freight transport management	(Browne et al., 2012)
	<b>Construction Logistics Plans (CLPs) - London</b>	Freight transport management	(Browne et al., 2012)
	<b>London Lorry Control Scheme</b>	Minimize noise pollution in residential areas during unsocial hours through restricted use of these roads	(Browne et al., 2012)
	<b>London Low Emission Zone (LEZ)</b>	Reduce air pollution and emissions per vehicle km	(Browne et al., 2012)
	<b>Loading time restrictions</b>	Noise levels caused by each freight journey	(Browne et al., 2012)
	<b>Ordering and delivery frequency</b>	Total vehicle kms / journeys by road in urban area	(Browne et al., 2012)
	<b>Urban Consolidation Centre (UCC) - London</b>	Improved logistics	(Browne et al., 2012)
<b>Increase maximum truck weight - UK</b>	Traffic levels, road haulage costs and emissions (2001)	(McKinnon, 2005)	
<b>Restricted access zones - U.K.</b>	Improve the efficiency of goods distribution in the city.	(Hull, 2005)	
Land-use	<b>Planning regulations (accessibility)</b>	Reduce aggregate travel demand and increase of sustainable transport modes	(Santos et al., 2010)
	<b>Mixed-use development and sprawl containment</b>	Reduce aggregate travel demand and increase of sustainable transport modes	(Santos et al., 2010)
	<b>Location of activities</b>	Total vehicle kms / journeys by road in urban area	(Browne et al., 2012)
Vehicle	<b>Vehicle engine emissions standards</b>	Fossil fuel consumption & local pollutant emissions per vehicle km	(Browne et al., 2012)

### 3.2.3 Considerations of the literature study

In this section a selection of eighteen traffic data is presented. The described data applies for all type of vehicles including HGVs. This because traffic data exclusive for the freight sector (e.g. type of cargo per HGV, classification of HGVs) is only of interest for the logistics sector. Four main sectors of urban transport development are also presented and described according to the impact freight traffic has in them. Both traffic data and urban development sectors are a selection done taking into account the urban development of the city of Eindhoven.

Authorities are aware of the problems caused by freight traffic and try to reduce as many negative impacts as possible. The information about the transport sectors, the traffic data, and the data collection methods of this section provide are the tools for creating an overview of the freight transport situation. This three elements are the base for the scientific methodology used to answer the main research question. The next step of this research is adopting an AHP and QFD methodology that will rank the available methods to collect traffic data. The method considers the opinion of different stakeholder groups about the importance of the urban transport problems related to freight traffic.

## 4 A combined AHP and QFD methodology for data collection technique evaluation

### 4.1 Introduction

Freight traffic data are crucial for representing the traffic status of the urban freight transport system. This data contributes to efficient decision-making from the authorities. Every city has different freight transport interests that depend on the city's characteristics. Freight traffic is related to the urban transport sectors of economy, logistics, infrastructure, land-use, and others. Therefore, traffic data is required for the sustainable management of urban logistics (Ibeas et al., 2012). It is important to identify the adequate method to collect the site-specific freight traffic data.

This research aims to identify the most adequate method to collect freight traffic data in the city of Eindhoven. This will contribute to create an overview of the city's traffic network status quo. The overview can assist the policy-making process decision makers of the Municipality. In Eindhoven the in-situ techniques video cameras and ILD have been used to perform traffic counts. However, authorities do not know what method to collect traffic data is more adequate. There is a lack of feedback about the usefulness of the collected traffic data. And there is no study performed about the different methods for data collection. Thus, this research is the first of its kind.

This study implies a societal contribution to an actual need from the authorities. Traffic data collection will aid the policy-making decision process in the city of Eindhoven. The scientific contribution is the use of the combined AHP and QFD methodology for the first time in freight traffic data collection.

#### **Research hypothesis.**

Probe vehicles should be the most adequate freight traffic data collection method for Eindhoven. This ITS method is related to Eindhoven's high tech and innovative smart city philosophy. Researchers as Leduc (2008) show the potential of this method to collect accurate and real-time traffic data.

There are many available methods for collecting traffic data. And exists the possibility for ITS not being a crucial factor in the method choice. A *secondary hypothesis* leads to the selection of Inductive Loop Detectors as an adequate option. ILD are a mature, complete, effective and evolved data collection method. Many studies have used this technique as data source. Two examples are traffic accidents detection and traffic network flow measurement (Gongjun et al., 2012; Mirchandani, Gentili, & He, 2009).

#### **Research design**

This research is one of its kind and has its own problem-solving approach. There is no study that evaluates the available methods for freight traffic data collection. Most of the studies involving traffic data collection methods are about specific traffic problems (e.g. emissions, congestion, etc.). Other studies are about a specific traffic data collection method. This results in a display of only few general features of the methods. An example of this is presented in

the city of Lyon France by Purson, Klein, Bacelar, Reclus, & Levilly (2015). They assess different data collection technologies for travel time estimation.

This research requires a rational approach for a decision-making process. Multi Criteria Evaluation (MCE), Conjoint Analysis, and Quality Function Deployment (QFD) are three decision-making methods. The MCE determines the preference ranking of alternatives that contribute to reach specific objectives. Similarly, conjoint analysis (also known as Discrete Choice Modeling) evaluates people's choices and identifies valuable factors in products and services. And QFD is used in new product development. QFD is a tool for transforming the customer needs into technical requirements.

Several studies relate the transport, traffic, and logistic sector to the decision-making approaches. Awasthi & Chauhan (2011) used MCE to identify, structure, and rate the impact of environment-friendly transport measures in city sustainability. They focused their study in motor vehicles moving people and freight. Vermeulen, Goos, & Vandebroek (2011) prove the efficiency of Conjoint Analysis for ranking choice-sets alternatives. Sohn (1999) apply QFD to prioritize traffic accident reduction control policies. The background of MCE and QFD methodologies make them adequate approaches for this investigation.

QFD is a customer-oriented methodology for product design and development. The main characteristic of this methodology is that integrates the customer requirements (WHATs) with the technical characteristics (HOWs) through a matrix called the House of Quality (HOQ). And takes into account all the different stages of the product development. From the early stage of product planning till process control, using different phases of the HOQ (Govers, 1996; Wang, Tong, Roucoules, & Eynard, 2008). In the literature review conducted by Chan & Wu (2002) QFD is categorized as a customer-driven and market-oriented employed methodology for the decision-making process

MCE has two main techniques: the Analytic Hierarchy Process (AHP) and the Analytical Network Process (ANP). The main difference between this two techniques is that AHP presents a hierarchical relationship with independent elements and ANP presents more complex interrelationships with interdependent elements. The problem-solving approach of this thesis use the AHP technique. AHP is a well-known method with particular application in decision-making processes. AHP is able to rank different alternatives according to their importance in a rational and consistent way. Compares diverse and incommensurable elements to one another (pairwise comparisons). This results in numerical weights of importance for each element of the hierarchy.

Studies relate QFD and AHP to the freight and transport sectors. AHP has been used for: evaluate traffic congestion in an intersection (Yu, Wang, & Gong, 2013); assess the economic, technical, environmental and social aspects of an integrated system of urban public transport (Nosal & Solecka, 2014); create an effective risk-based route network for HGVs (Sattayaprasert, Hanaoka, Taneerananon, & Pradhananga, 2008); and evaluate and select logistics outsourcing service suppliers (Peng, 2012). QFD has been used for: prioritize most of the tasks of any industry (Bhattacharya et al., 2010); prioritize traffic accident reduction control policies (Sohn, 1999); and as a tool for the transportation sector (automotive parts, transportation equipment), communication, and services (retail, wholesale, packaging) (Chan

& Wu, 2002). There is no study using AHP or QFD to evaluate the freight traffic data collection methods.

The research methodology of this paper is based in a combination of AHP and QFD methodologies. Using only QFD the traffic data collection methods can be ranked according to their relationship with freight traffic data. And freight traffic data can be matched with the different problems urban transport development sectors. But an accurate ranking of this problems cannot be achieved without a selected group of experts in freight transport and in traffic data collection methods. To tackle this, the AHP methodology ranks the environmental, social, and economic impacts from the freight traffic based on the opinion of the different stakeholders involved in the freight transport sector. By combining this two methodologies, the importance of the urban transport development sectors are transmitted to the QFD analysis. And the interests of Dutch stakeholders are the main input for traffic data and traffic data collection methods evaluation. AHP and QFD have been combined before in several studies (Bhattacharya et al., 2010; Chan & Wu, 2002; Ho et al., 2012; Liao & Kao, 2014).

### **Chapter overview**

The rest of this chapter is organized as follows: next section introduces the basic principles of AHP and QFD and their combination background. Then the utilized AHP and QFD combined methodology is described in detail in section 4.3. Section 4.4 presents an analysis of the obtained results. Finally section 4.5 provides a discussion of the findings.

## **4.2 The AHP and QFD methodologies**

### **4.2.1 Analytic hierarchy process (AHP)**

Analytic Hierarchy Process method was created and introduced by the professor Thomas Saaty (1980). AHP applies the concepts of multi-criteria decision-making (MCDM). The AHP method assists the decision maker to set stakeholders' priorities of different alternatives. Is considered an effective tool to solve complex problems that cannot be solved in a straightforward manner.

The AHP tool has both qualitative and quantitative components. It identifies decision criteria (qualitative component) and assigns weights to the criteria (quantitative component). Utilizes a structural model for the decision problem and then performs decision model analysis. Reduces complex decisions to a series of pairwise comparisons, and then synthesizes the results. Also incorporates a useful technique for checking the consistency of the decision maker's evaluations. Thus reduces the bias in the decision making process.

This method is based in a decision hierarchy. A typical decision hierarchy involves a goal, criteria or objectives and alternatives of choice (see figure 4-1). The decision makers make judgments on the elements of the hierarchy in pairs with respect to their parent element to derive priorities (pairwise comparisons). Then the evaluator synthesizes the priorities into an overall result.



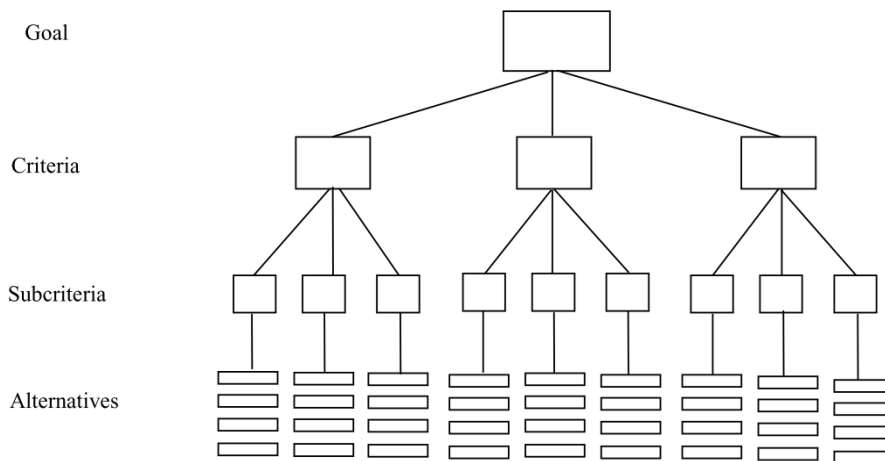

Figure 4-1. Decision Hierarchy (Curry & Davies 1995)

AHP is the one of the most systematic analytical techniques of MCDM. It facilitates the definition of priorities and preferences of decision makers. And is used as an analytical tool in various fields of studies. Broadly the technique considers the following steps for modeling any problem under consideration:

- a. Defining a site-specific hierarchic structure
- b. Calculating weights
- c. Computing inconsistency ratios.

AHP is an adequate tool for ranking of alternatives based on subjective criteria. Thus, this thesis use AHP to rank the urban transport development sectors (criteria) and the freight traffic problems related to this sectors (sub-criteria).

#### 4.2.2 Quality function deployment (QFD)

Quality function deployment is a customer-oriented methodology for product design and development (Akao, 1997). Developed in Japan in the late 1960s under the Total Quality Control philosophy by Shigeru Mizuno and Yoji Akao. QFD is a well-structured, cross-functional planning technique that is used to hear the customers' voice throughout the product planning, development, engineering and manufacturing stages of any product.

The main tool of the QFD is the House of Quality (HOQ) matrix. HOQ connects customer requirements (WHATs) to the technical characteristics (HOWs) of a product (see figure 4-2). Not all of the HOQ components have to be in all QFD analysis. The components of the HOQ are:

- (a) **Customer attributes:** Voice of the customer (WHATs).
- (b) **Customer assessment:** Evaluation of the WHATs.
- (c) **Attributes importance:** Weight of importance of the WHATs.
- (d) **Technical requirements.** Characteristics of the product (HOWs).
- (e) **Relationship matrix:** Relates the WHATs with the HOWs.
- (f) **Correlation matrix:** Correlates the HOWs, can also be used for the WHATs.
- (g) **Target values:** Depend on the product and the company objectives.
- (h) **Technical assessment:** Technical difficulty to implement the requirements.
- (i) **Weights of the HOWs:** Main result (output) from the HOQ.

According to Chan & Wu (2005) components (f), (g), and (h) can be omitted. The correlation matrix is often excluded due its complexity to fill in. And target values and technical assessment are not always available.

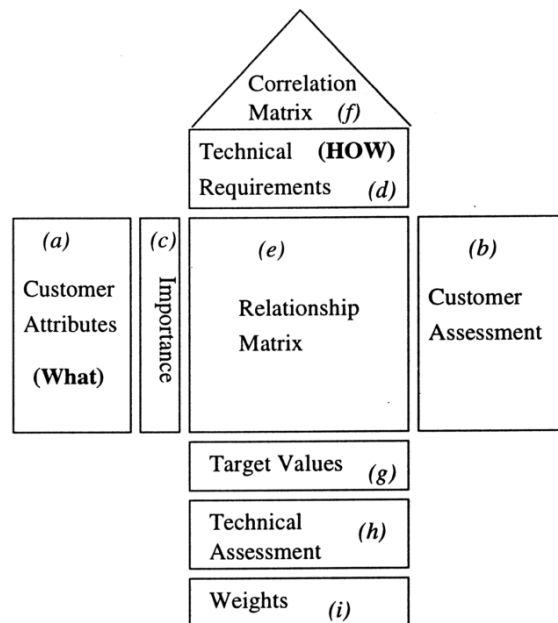

Figure 4-2 House of Quality matrix (Temponi, Yen, & Tiao, 1999)

Typically, a QFD system employs four inter-linked phases to fully deploy the customer needs. Each phase can be described by a HOQ matrix (see figure 4-3). The phases translate the important outputs (HOWs) produced in one stage into the next phase's inputs (new WHATs). It is not necessary to construct all four houses every time that a QFD is performed.

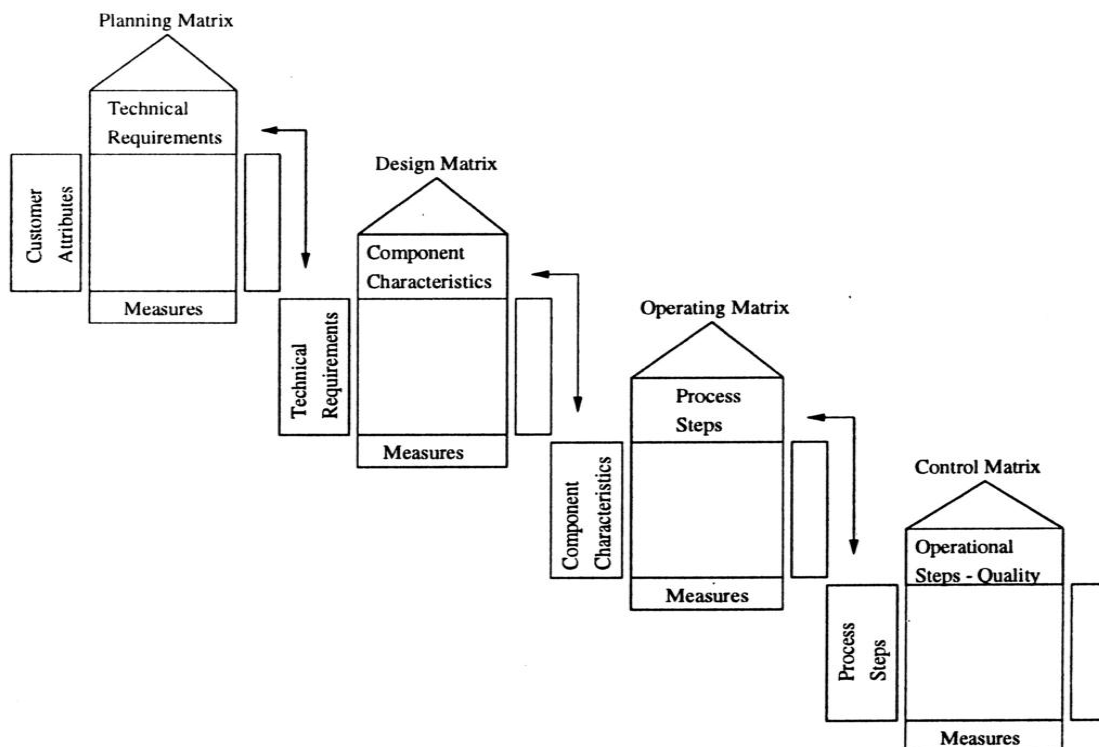

Figure 4-3 Quality Function Deployment process (Temponi et al., 1999)

The four QFD phases include:

- **Phase I – Product planning.** Translates customer needs into product design attributes which are called technical requirements. Obtaining good results from this phase is critical to the success of the entire QFD process.
- **Phase II – Product design.** Translates important technical measures into parts characteristics. Normally led by the engineering department. This phase delivers potential product features into component characteristics.
- **Phase III – Operation process.** Translates important component characteristics into process operations steps. Manufacturing processes are flowcharted and process parameters are documented. Also known as Process Design or Process Planning phase (Govers, 1996).
- **Phase IV – Process Control.** Translates key process operations into day to day production requirements or operational steps. Also known as Manufacturing Operations phase (Govers, 1996).

QFD methodology in this research uses two phases. Phase I relates the freight traffic problems (WHATs) with the freight traffic data (HOWs) and prioritize freight traffic data. Phase II matches the freight traffic data (WHATs) with the traffic data collection methods (HOWs) and prioritize the data collection methods.

#### 4.2.3 AHP and QFD

The combination of this two methods has a solid background as can be seen in the literature review conducted by Chan & Wu (2002). The approach for integrating the AHP and QFD methodologies varies depending on the problem. This thesis uses AHP to prioritize the customer needs of the QFD matrix. This problem-solving approach has been used before in many different studies. Bhattacharya et al. (2010) used it for supplier selection in the logistics sector, Liao & Kao (2014) to improve the logistics service operation, Ho et al. (2012) to select a service provider company, and Chan & Wu (2002) present more examples of this approach. The utilized research approach is described in next section.

### 4.3 Combined AHP and QFD methodology

This research identifies the problems affecting the urban freight transport sectors. Then performs a multi-stakeholder AHP analysis of the problems in The Netherlands. AHP results prioritize the problems affecting the urban freight transport sector. Then, a first phase of the QFD rank freight traffic data (technical requirements) using the AHP results as customer requirements. Finally, a second QFD phase rank the traffic data collection methods using the first phase results (freight traffic data) as customer requirements. This second phase of the QFD take into account the pros and cons of each method and their performance in the city of Eindhoven. The combined approach used in this research is detailed described next.

#### 4.3.1 AHP for prioritizing freight traffic criteria

Policy makers need to understand the importance of freight traffic related problems. This is useful information for their decision-making process. The AHP methodology aims to prioritize the freight traffic related problems of The Netherlands. A decision hierarchy model identify and rank different sectors and problems related to the freight transport sector.

A multi-stakeholder AHP analysis is performed for The Netherlands. Different stakeholders from the freight transport sector are surveyed through questionnaires. AHP methodology results in a priority vector (weights of importance) for the different elements of the hierarchy.

### Participants, sample, and measurement

This model intends to take into account interests from all different freight transport stakeholders. The urban freight transport sector of the Netherlands has many different parties involved. Companies, organizations, partnerships, common people, and others are combined in five stakeholders groups:

- Authorities (local and national authorities, public-private partnerships, etc.)
- Mobility experts (automotive manufacturers, researchers, consultants, IT companies)
- Freight and logistics companies (fleet operators, logistic server provider, carriers)
- Retailers (producer-wholesaler, wholesaler-retailer)
- Citizens (end consumers)

This research targets expert opinions. This means that the participants should be qualified professionals representing each stakeholder group. Therefore the first step was to identify the experts that would integrate the sample. Due the scope of this investigation of selecting a traffic data collection method for Eindhoven. Respondents had to be located in the city or have a direct influence in it. This was the first criteria to choose the participants for this method. Problems came up when trying to reach participants from the locality. Only few experts of the city were willing to participate in the research. Therefore, the range for the search of experts grew to a national level.

The contact with the targeted companies was via e-mail and phone calls. From a total of 33 contacted companies, fifteen companies participated in this research. Five of them refused to participate and the rest no replied (see figure 4-4).



Figure 4-4. Participating companies

The same amount of participants per stakeholder group would integrate an ideal scenario. This scenario was not achieved though. The low participation of the involved stakeholders hindered a balanced sample. The reasons from the companies that refused to participate included:

- The contacted person was not authorized for forwarding the information to experts.
- Insufficient personnel capacity.
- Not agreeing with the contribution of the research for Eindhoven policy-making.
- Not considered themselves experts.
- Not interested in participating.

The data was collected using an online questionnaire. This questionnaire is further described in the next paragraphs.

**The AHP model**

The AHP model of this research is based on the 7-step structured decision process suggested by Curry & Davies (1995):

1. Problem definition and research
2. Eliminating infeasible alternatives
3. Structuring a model
4. Making judgements
5. Synthesizing
6. Examining and verifying the decision
7. Documenting the decision

The problem tackled is to prioritize the freight traffic related problems of The Netherlands. Taking into account the different freight transport sectors and stakeholders. A top down approach is adopted because more is known about the problem than about the alternatives to solve it. The criteria, sub-criteria and alternatives are identified based on the literature review (section 3.2.2).

The AHP model is formed (see figure 4-5) taking into account the recommendation of Curry & Davies (1995): “A hierarchy should be large enough to represent your major concerns and small enough to be responsive to change”.

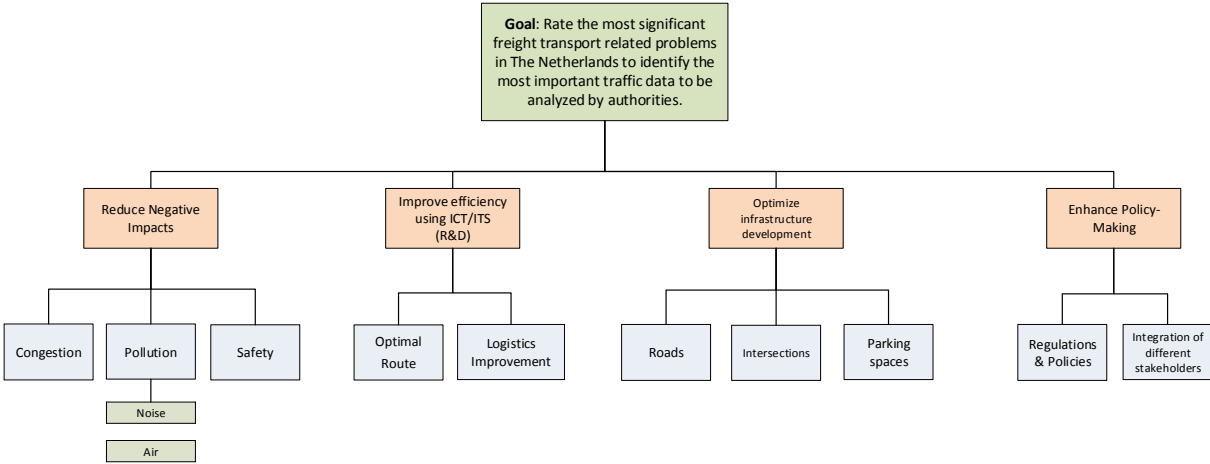

Figure 4-5 Hierarchy tree diagram (AHP model)

The next step is to ask the participants to make a pairwise comparison of all elements of the AHP model. The amount of judgments required for a matrix of order n is given by equation 4.1. The scale used by the respondents to compare each pair of elements is the traditional 9 points scale. The comparisons made by the respondents are presented in table 4.1.

$$\#judgments = n(n - 1)/2 \quad (4.1)$$

Table 4.1 Pairwise comparisons

Reduce negative impacts	9	8	7	6	5	4	3	2	1	2	3	4	5	6	7	8	9	Improve efficiency using ICT/ITS
Reduce negative impacts	9	8	7	6	5	4	3	2	1	2	3	4	5	6	7	8	9	Infrastructure Optimization
Improve efficiency using ICT/ITS	9	8	7	6	5	4	3	2	1	2	3	4	5	6	7	8	9	Infrastructure Optimization
Reduce negative impacts	9	8	7	6	5	4	3	2	1	2	3	4	5	6	7	8	9	Enhance Policy-Making
Improve efficiency using ICT/ITS	9	8	7	6	5	4	3	2	1	2	3	4	5	6	7	8	9	Enhance Policy-Making
Infrastructure Optimization	9	8	7	6	5	4	3	2	1	2	3	4	5	6	7	8	9	Enhance Policy-Making
Congestion	9	8	7	6	5	4	3	2	1	2	3	4	5	6	7	8	9	Pollution
Congestion	9	8	7	6	5	4	3	2	1	2	3	4	5	6	7	8	9	Safety
Pollution	9	8	7	6	5	4	3	2	1	2	3	4	5	6	7	8	9	Safety
Noise Pollution	9	8	7	6	5	4	3	2	1	2	3	4	5	6	7	8	9	Air pollution
Route optimization	9	8	7	6	5	4	3	2	1	2	3	4	5	6	7	8	9	Logistics improvement
Roads	9	8	7	6	5	4	3	2	1	2	3	4	5	6	7	8	9	Intersections
Roads	9	8	7	6	5	4	3	2	1	2	3	4	5	6	7	8	9	Parking spaces
Intersections	9	8	7	6	5	4	3	2	1	2	3	4	5	6	7	8	9	Parking spaces
Regulations	9	8	7	6	5	4	3	2	1	2	3	4	5	6	7	8	9	Integration of different sectors

A questionnaire is designed as a survey tool. This research used an online-questionnaire (see appendix 7). The questionnaire design included:

- A clear statement about the goal of the research.
- Measures to identify the stakeholder group.
- Instructions to fill it in.
- The pairwise comparisons to judge the AHP model elements.
- An e-mail contact field (optional).

The e-mail contact was only a preventive measure for the probable inconsistent questionnaires. This research guaranteed complete anonymity of the respondents.

The responses of the participants need to be synthesized after collecting the answered questionnaires. To do this three matrices are formed. A matrix of order 4 for comparing the criteria and two matrices of order 3 to compare the sub-criteria of the negative impacts and infrastructure. The rest of the comparisons are synthesized as single comparisons.

The matrices of pairwise comparisons are formed by capturing the judgments of the respondents in the upper diagonal of the matrix. If the respondent selected the left element as more important, the numeric value is captured as an integer. If the respondent selected the right element as more important, the numeric value it is captured as the reciprocal. The values below the diagonal are the reciprocals of the upper diagonal values. The diagonal has always the value of 1 because is the element compared to itself. This process is illustrated in example 1.

**Example 1.**

*A respondent makes the following selection when comparing the infrastructure sub-criteria:*

Congestion	9	8	7	6	5	4	3	2	1	2	3	4	5	6	7	8	9	Pollution
Congestion	9	8	7	6	5	4	3	2	1	2	3	4	5	6	7	8	9	Safety
Pollution	9	8	7	6	5	4	3	2	1	2	3	4	5	6	7	8	9	Safety

*The pairwise matrix is formed in two steps:*

1. *Capturing the respondent values*
2. *Calculating the reciprocals*

Step 1	Congestion	Pollution	Safety
Congestion	1,00	5	1/3
Pollution		1,00	1/7
Safety			1,00

Step 2	Congestion	Pollution	Safety
Congestion	1,00	5	1/3
Pollution	1/5	1,00	1/7
Safety	3	7	1,00

Then is necessary to examine the consistency of the questionnaires. For this the Consistency Index (CI) and Consistency Ratio (CR) are calculated for each matrix using equations 4.2 and 4.3 (Saaty, 1980).

$$CI = \frac{\lambda_{max} - n}{n - 1} \quad (4.2)$$

$$CR = \frac{CI}{RI} \quad (4.3)$$

Where  $\lambda_{max}$  is the principal eigenvector of the matrix of order  $n$ .  $RI$  is the random consistency index for different matrix orders (see table 4.2).

Table 4.2 Random Index values (Saaty, 1980)

n	2	3	4	5	6	7	8	9	10
RI	0	0.58	0.90	1.12	1.24	1.32	1.41	1.45	1.51

Small values of inconsistency ( $CR < 0.12$ ) are tolerated. A perfectly consistent pairwise matrix has  $CR = 0$ . A questionnaire is considered inconsistent when 1 or more matrix has a  $CR > 0.12$ .

**Adjusted questionnaires**

In case that only one of the matrices from a questionnaire has a  $CR > 0.12$ , this research follows Saaty (2004) recommendation for adjusting the CR value:

- 1) Find the most inconsistent judgment in the matrix.
- 2) Determine the range of values to which that judgment can be changed corresponding to which the inconsistency would be improved.

3) Ask the decision maker to consider changing his judgment to a value in that range. In this research the respondent is never asked to change his opinion about what element of the pairwise comparison is more important. The respondent is only asked to adjust the value of importance of the element or to consider both of equal importance. This restriction is done to preserve the integrity of the respondent first choice. The participants were contacted via e-mail to adjust their answers, the format utilized is in appendix 8.

### **Documenting the decision**

After the questionnaires are individually analyzed, all consistent questionnaires are integrated using a geometric mean and then normalized for obtaining the general priority vector from the criteria and sub-criteria of the AHP model.

#### **4.3.2 QFD for ranking traffic data collection methods**

Eindhoven aims to identify an adequate freight traffic data collection method for the city. The first two phases of the QFD methodology are used to achieve this goal. Phase I (product planning) uses the results of the AHP as customer requirements and ranks the freight traffic data. Phase II (product design) rank the traffic data collection methods using phase I results (freight traffic data) as customer requirements. This second phase of the QFD take into account the methods' characteristics and performance in the city of Eindhoven.

### **Participants, sample and measurement.**

Phase I and phase II of the QFD method are filled in by the author of this thesis. The author adopted the role of expert on freight traffic data collection. The literature review presented in chapter 3 is the capacitation used to obtain the expertise. A group of experts in the subject was difficult to identify due the complexity of the technical requirements of both phases of the QFD and were not identified due time limitations. The QFD methodology of this research is based in the process proposed by Chan & Wu (2005).

**QFD phase I.** Phase I of the QFD uses the following HOQ components:

1. Customer attributes.
2. Customer assessment.
3. Attributes importance.
4. Technical requirements.
5. Relationship matrix.
6. Correlation matrix (WHATs and HOWs).
7. Weights of the HOWs.

The first 3 steps are the output information from the from the AHP methodology. Customer attributes (WHATs) are the identified problems. Customer assessment is the AHP methodology. And the attributes importance is the priority vector obtained from AHP. The freight traffic data (HOWs) are identified and related to the (WHATs) using the literature review of chapter 3 (see appendix 2). These relationships are measured by the scale showed in figure 4-6. The value assigned to each relationship is done based on literature review and assumptions. The following assumptions are criteria used to assign numeric values for the relationship matrix:



- Traffic data depending on other variables had a lower value than independent traffic data. E.g. volume is a raw data and has a higher value than density which is volume/road length.
- Traffic data highly related to the traffic problem had a higher value than other data. E.g. traffic noise for noise pollution.
- Complementary traffic data for the problem analysis had a ‘very weak’ relationship.

Section 3.2.1 identified the important variables for the freight transport sector. This variables have a higher value of relationship. Also vehicle type and vehicle ID are considered data of higher importance because they can niche HGVs traffic data. Literature and assumptions used for correlate WHATs and HOWs are listed in appendix 9.

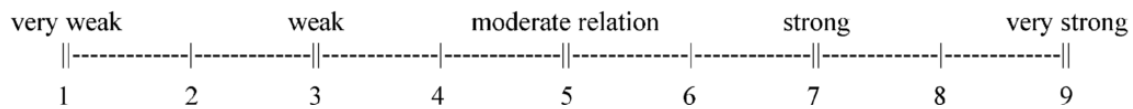

Figure 4-6 Relationship matrix weights

The correlation matrices of the WHATs and HOWs are filled in based on assumptions and literature review. The correlations are measured by the scale showed in figure 4-7. The QFD model of this research discard negative correlations. Even if the parameters affect each other negatively are assumed only to reinforce each other’s importance.

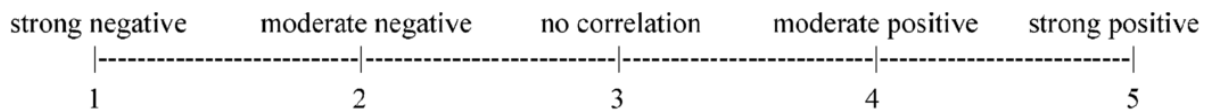

Figure 4-7 Correlation matrix weights

The importance ratings of the HOW is the main output of the HOQ process. The technical requirement weights are obtained using equation 4.4. This weights allow to prioritize the freight traffic data to be collected. The QFD phase II is described next.

$$\tau = \frac{\sum((importance\ of\ HOW \times relationship\ matrix\ value) * correlation\ value\ of\ HOW)}{(4.4)}$$

**QFD phase II.** Phase I of the QFD uses the following HOQ components:

1. Customer attributes.
2. Customer assessment.
3. Attributes importance.
4. Technical requirements.
5. Relationship matrix.
6. Weights of the HOWs.

Again the customer attributes, their assessment and importance are pre-defined by the results of phase I of the QFD. The HOWs of phase I (freight traffic data) become the WHATs on the second phase.

The traffic data collection methods (HOWs) are identified and related to the (WHATs) using a literature review (see appendix 10). These relationships are measured by the scale showed in figure 4-6. The value assigned to each relationship is done based on literature review and assumptions. The following parameters are used to assign numeric values for the relationship matrix:

General sensor parameters:

- Accuracy of the sensor to obtain specific type of data.
- Performance of the sensor.
  - Under weather conditions
  - Single lane or multi-lane coverage
  - Level of maintenance needed.
- Installation difficulty.
- Technology and costs (€). Based on cost/performance tables of appendix 11.

Sensor parameters related to Eindhoven characteristics:

- Performance under rain and fog weather conditions.
- Capacity to detect bicycles
- ITS application

Phase II not utilizes the correlation matrix. The WHATs have been already correlated in phase I. The methods are only correlated when they work together in traffic data collection systems. This is an individual analysis of each method's capacities to collect traffic data.

The importance ratings of the HOW is the main output of the HOQ process. The technical requirement weights are obtained using equation 4.5.

$$\tau = \sum(\text{importance of HOW} \times \text{relationship matrix value}) \quad (4.5)$$

This weights allow to rank the traffic data collection methods according to the importance of freight traffic data obtained in QFD phase I.

## 4.4 Result analysis

### 4.4.1 AHP results

The 33 contacted companies can be seen in table 4.3. The percentage of contacted companies per sector can be seen in figure 4-8. The students of the MSc Construction Management and Engineering (CME) are considered expert citizens due their background in the urban build environment sector. The rest of the companies are categorized depending on their connection with the freight sector. The logistics and delivery companies are part of the freight group. Companies specialized in commercial property investment and commercial real estate are retail. Companies or institutions that normally do research are mobility experts. And companies related to policy-making are considered authorities.

Table 4.3 Companies by stakeholder group.

Authorities	Mobility Experts	Citizens	Freight	Retail
Municipality Eindhoven	DAF	MSc CME Students	DFC (Dutch Fright Company B.V.)	Multi
ANWB	Smart Mobility TU/e		EVO	Corio
Rijkwaterstraat	TNO		Princen	Unibail Rodamco
Dinalog	Smart Mobility Meet		DPD Best	
TrafficQuest	Urban Planning TU/e		CB voorheen Fashion Wheels	
ACEA	MSc OML TU/e		TLN - Transport and Logistics Netherlands	
	ICA		TNT	
	DITCM		DHL	
	NedMobiel		Lekkerland Nederland B.V.	
	Logistics TU/e		Dutch Freight Services B.V.	
	TU/Delft		Van Gansewinkel Eindhoven	
	CONNEKT			
<b>6</b>	<b>12</b>	<b>2</b>	<b>10</b>	<b>3</b>

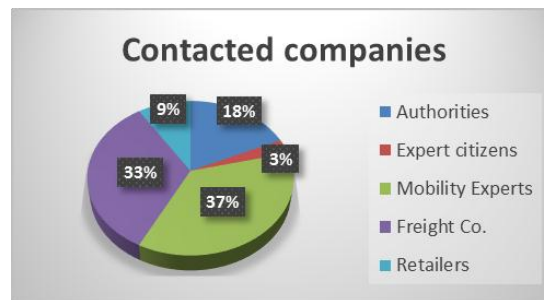

Figure 4-8 Contacted companies per sector

A total of 86 questionnaires were sent to the 33 contacted companies. The amount of questionnaires sent per stakeholder group is the following: authorities 10, citizens 23, mobility experts 41, freight companies 9, and retailers 3. The detail is showed in figure 4-9.

A total of 42 questionnaires were answered. This thesis considered a CR < 12% as an acceptable tolerance of inconsistency. The consistent questionnaires were 23, used for the calculation of the priority vector of the criteria. The inconsistent questionnaires were 17 and 2 respondents did not reconsidered their single inconsistent answer (see figure 4-10).

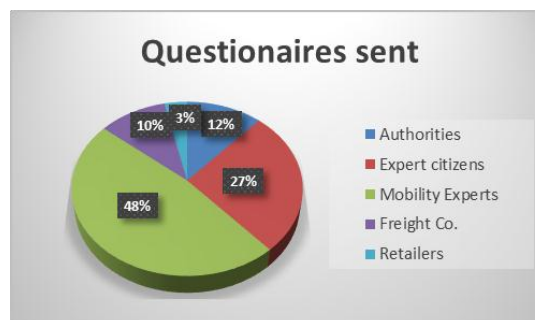

Figure 4-9 Percentages of questionnaires sent



Figure 4-10 Respondents overview

From the original responses, only 9 questionnaires were consistent. However, 14 questionnaires had only 1 inconsistent answer. This respondents were contacted via e-mail (using the format of appendix 8) and only 2 of them did not reconsidered their opinion. One of them because of no e-mail contact details. Also a CR < 25% was accepted for the retail and freight sectors. Obtaining a total of 23 useful questionnaires. The useful questionnaires per stakeholder group is the following: citizens 10, mobility experts 6, authorities 5, freight 1, and retailer 1. Figure 4-11 present the percentage of useful questionnaires per stakeholder group.



Figure 4-11 Used questionnaires per stakeholder groups

**Analysis**

The 23 useful answers are grouped together using a geometric mean (see table 4.4). The priority vector of the criteria and sub-criteria is obtained after normalizing the geometric mean matrix (see table 4.5). This AHP matrix is named AHP version 1 (V.1).

The results of the AHP method without the adjustment of 25% for this sectors can be seen in appendix 12. This are a total of 20 questionnaires with CR < 12% and the AHP matrix is called version 1.1 (V.1.1).

Then an analysis was done for considering the different interests of stakeholders groups. Questionnaires were grouped by stakeholder and analyzed in five independent matrices (see figure 4-12). This five matrices were then grouped together in one AHP matrix. This AHP matrix is named AHP version 2 (V.2) In AHP V.2 each stakeholder group has 20% influence in the result. The priority vector of AHP V.2 is in appendix 12.

Table 4.4 AHP V.1 geometric mean (23 answers)

Geometric mean	Reduce negative impacts	Improve efficiency using ICT/ITS	Optimize infrastructure	Enhance Policy-Making	Congestion	Pollution	Safety	Noise Pollution	Air Pollution	Optimal Route	Logistics improv.	Roads	Intersections	Parking	Regulations	Stakeholders	Geometric mean			CI	CR	
																	Geometric mean	Priority vector	$\lambda_{max}$			
Reduce negative impacts	1,00	2,18	1,63	2,03														1,64	0,39	4,02	0,005	0,000
Improve efficiency using ICT/ITS	0,46	1,00	0,82	1,41														0,85	0,20			
Optimize infrastructure	0,61	1,22	1,00	1,57														1,04	0,25			
Enhance Policy-Making	0,49	0,71	0,64	1,00														0,69	0,16			
Congestion					1,00	0,90	0,54											0,78	0,25	3,00	0,000	0,000
Pollution					1,11	1,00	0,60											0,87	0,28			
Safety					1,86	1,67	1,00											1,46	0,47			
Noise Pollution								1,00	0,36									0,60	0,26	2,00	0,000	0,000
Air Pollution								2,80	1,00									1,67	0,74			
Optimal Route										1,00	0,72							0,85	0,42	2,00	0,000	0,000
Logistics improv.										1,39	1,00							1,18	0,58			
Roads												1,00	0,61	1,77				1,02	0,32	3,01	0,006	0,010
Intersections												1,65	1,00	2,11				1,52	0,48			
Parking												0,57	0,47	1,00				0,64	0,20			
Regulations															1,00	0,94		0,97	0,48	2,00	0,000	0,000
Stakeholders															1,07	1,00		1,03	0,52			

A combined AHP and QFD methodology for data collection technique evaluation

Table 4.5 AHP V.1 priority vector (23 questionnaires)

Normalization	Reduce negative impacts	Improve efficiency using ICT/ITS	Optimize infrastructure	Enhance Policy-Making	Congestion	Pollution	Safety	Noise Pollution	Air Pollution	Optimal Route	Logistics improv.	Roads	Intersections	Parking	Regulations	Stakeholders	criteria weight vector	alternatives scores	overall value of each option	alternatives 4th level	Ranking
Reduce negative impacts	0,39	0,43	0,40	0,34													<b>0,39</b>				1
Improve efficiency using ICT/ITS	0,18	0,20	0,20	0,24													0,20				3
Optimize infrastructure	0,24	0,24	0,24	0,26													0,25				2
Enhance Policy-Making	0,19	0,14	0,16	0,17													0,163				4
Congestion					0,25	0,25	0,25											0,25	0,10		5
Pollution					0,28	0,28	0,28											0,28	<b>0,11</b>		4
Safety					0,47	0,47	0,47											<b>0,47</b>	<b>0,18</b>		1
Noise Pollution								0,26	0,26									0,26		0,03	
Air Pollution								0,74	0,74									<b>0,74</b>		0,08	
Optimal Route										0,42	0,42							0,42	0,085		6
Logistics improv.										0,58	0,58							0,58	<b>0,118</b>		2
Roads												0,31	0,29	0,36				0,32	0,079		8
Intersections												0,51	0,48	0,43				<b>0,48</b>	<b>0,117</b>		3
Parking												0,18	0,23	0,21				0,20	0,05		10
Regulations															0,48	0,48		<b>0,48</b>	0,079		9
Stakeholders															0,52	0,52		0,52	0,084		7

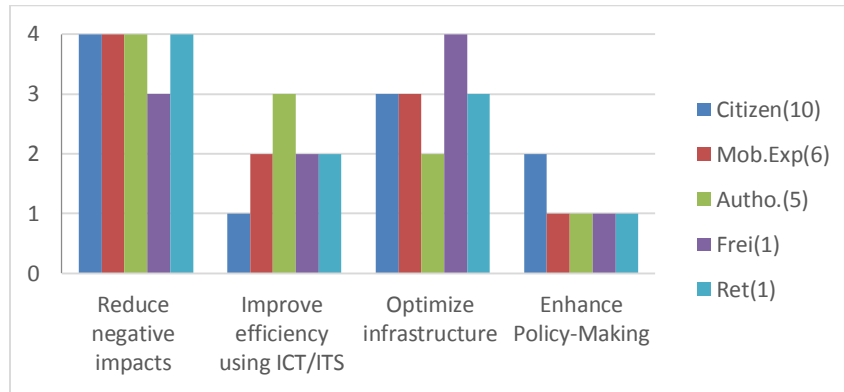

Figure 4-12. AHP V.2 criteria ranking per stakeholder

A new analysis is done because AHP V.2 gives high influence power to the freight and retail sectors. Both sectors have only one respondent each. Those 2 stakeholder groups are grouped in one stakeholder called *Fretail*. This makes four stakeholder groups to take into account in the AHP version 3 (V.3). In AHP V.3 each stakeholder has 25% influence in the result (see figure 4-13). The priority vector of AHP V.3 is presented in table 4.6.

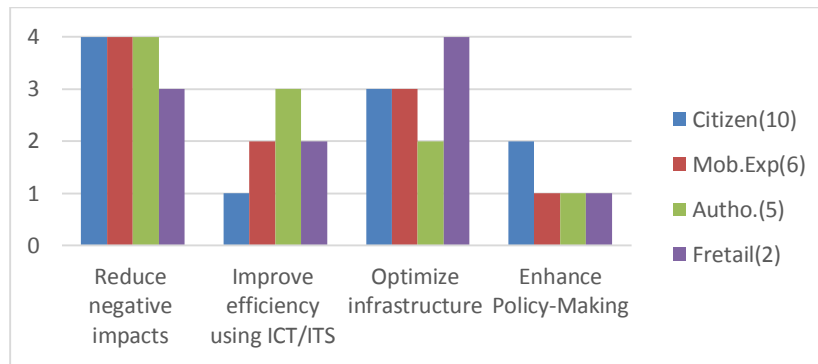

Figure 4-13. AHP V.3 criteria ranking per stakeholder

Four different scenarios were created from the AHP analysis. When all scenarios are compared, the overall result of the criteria ranking is the same for all of them (see figure 4-14). The sub-criteria has several fluctuations among scenarios (see figure 4-15). The scenarios are:

1. Version 1 – Freight and retail questionnaires with CR < 25% (23 respondents)
2. Version 1.1 – All questionnaires with CR < 12% (20 respondents)
3. Version 2 – Individual matrices for the five stakeholder groups (23 respondents)
4. Version 3 – Individual matrices for four stakeholder groups (23 respondents)

AHP version 3 is considered the most adequate output of the AHP methodology. This AHP matrix takes into account all consistent questionnaires and makes an individual analysis per stakeholder group. This takes into account that freight and retail stakeholders have only 2 respondents in total. AHP V.3 no have significant differences when compared to AHP version 1 (see figure 4-16). Thus, the results of AHP V.3 are used as input for QFD phase I (see table 4.7).

Table 4.6 AHP V.3 priority vector (4 stakeholder groups)

Normalization	Reduce negative impacts	Improve efficiency using ICT/ITS	Optimize infrastructure	Enhance Policy-Making	Congestion	Pollution	Safety	Noise Pollution	Air Pollution	Optimal Route	Logistics improv.	Roads	Intersections	Parking	Regulations	Stakeholders	criteria weight vector	alternatives scores		Ranking
																		overall value of each option	alternatives 4th level	
Reduce negative impacts	0,39	0,45	0,39	0,31													0,38		1	
Improve efficiency using ICT/ITS	0,17	0,20	0,21	0,26													0,21		3	
Optimize infrastructure	0,27	0,26	0,27	0,29													0,27		2	
Enhance Policy-Making	0,17	0,10	0,13	0,14													0,13		4	
Congestion					0,35	0,34	0,35											0,35	0,132	3
Pollution					0,25	0,25	0,25											0,25	0,096	5
Safety					0,40	0,41	0,40											0,40	0,154	1
Noise Pollution								0,28	0,28									0,28		0,03
Air Pollution								0,72	0,72									0,72		0,07
Optimal Route										0,37	0,37							0,37	0,077	7
Logistics improv.										0,63	0,63							0,63	0,133	2
Roads												0,31	0,29	0,36				0,32	0,087	6
Intersections												0,47	0,43	0,39				0,43	0,117	4
Parking												0,22	0,28	0,26				0,25	0,069	8
Regulations															0,48	0,48		0,48	0,064	10
Stakeholders															0,52	0,52		0,52	0,070	9



A combined AHP and QFD methodology for data collection technique evaluation

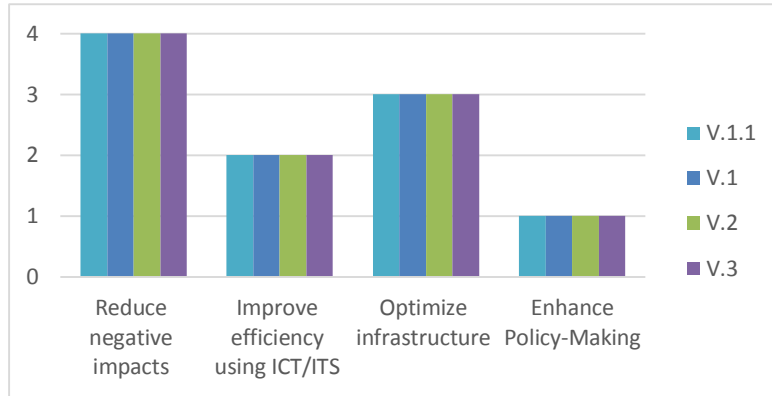

Figure 4-14 Criteria ranking per scenario

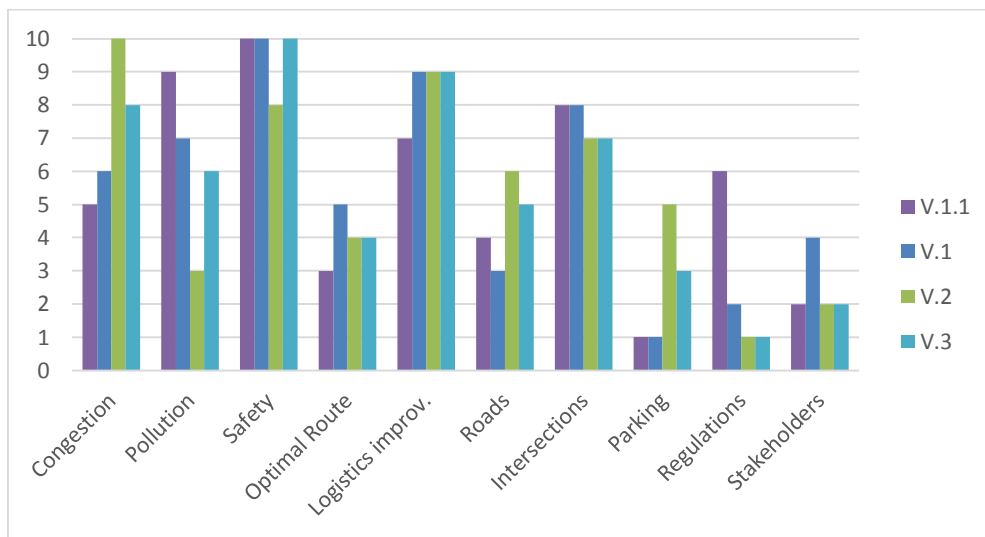

Figure 4-15 Sub-criteria scenarios comparison

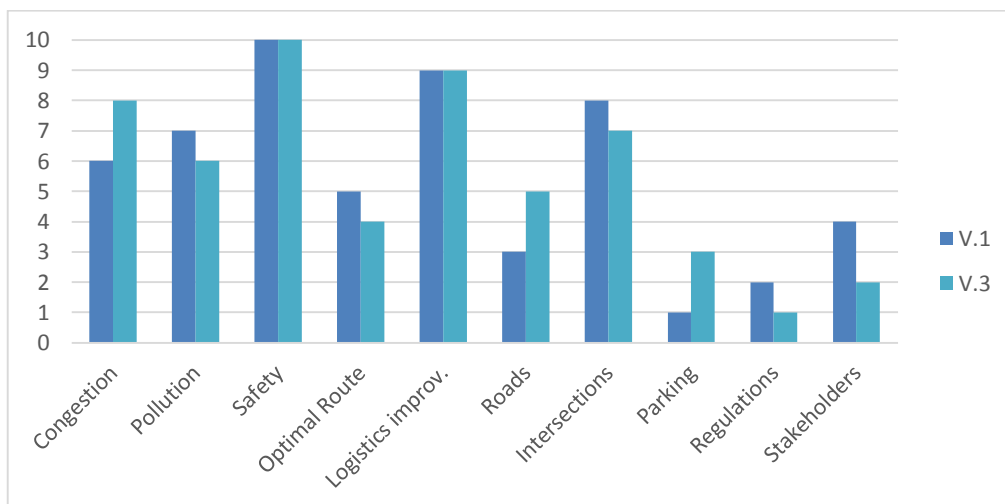

Figure 4-16 Sub-criteria comparison AHP V.1 and AHP V.3

Table 4.7 Sub-criteria final ranking and weight of importance (input for QFD phase I).

Rank	Criteria	Weight
1	Safety	15,45%
2	Logistics improvement	13,32%
3	Congestion	13,22%
4	Intersection	11,72%
5	Pollution	9,59%
6	Roads	8,72%
6	Optimal Route	7,69%
8	Parking	6,94%
9	Stakeholder integration	6,96%
10	Regulations	6,39%

#### 4.4.2 QFD results

##### QFD phase I.

A HOQ is formed to relate the freight traffic related problems (WHATs) to the freight traffic data (HOWs). The QFD phase I HOQ matrix can be seen in figure 4-17. And the results of the weights of importance of the freight traffic data are displayed in figure 4-18.

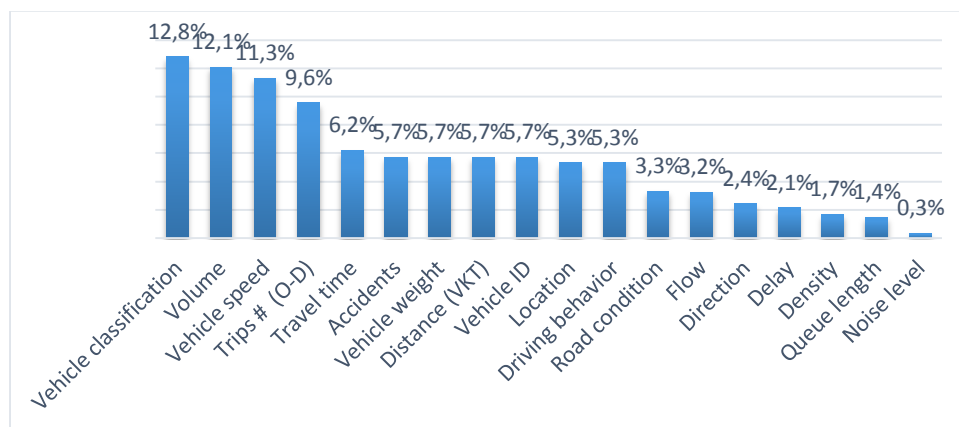

Figure 4-17 Freight traffic data ranking

Two alternative scenarios are proposed to analyze the QFD phase I results:

**Scenario 1.** Traffic data variables are not affected by the freight importance. This means a scenario that analyze all type of traffic data.

**Scenario 2.** Freight traffic data is analyzed only for air pollution. All other WHATs in the QFD matrix are not taken into account. This scenario is selected according to the Municipality interests regarding freight traffic analysis.

The different results obtained with this scenarios (see figure 4-19) contribute to propose a general ranking for traffic data importance. This ranking is done by averaging the weights obtained in the three scenarios (see figure 4-20). However, this outcome is out of the scope of this thesis due its focus on general traffic instead of freight traffic.

A combined AHP and QFD methodology for data collection technique evaluation

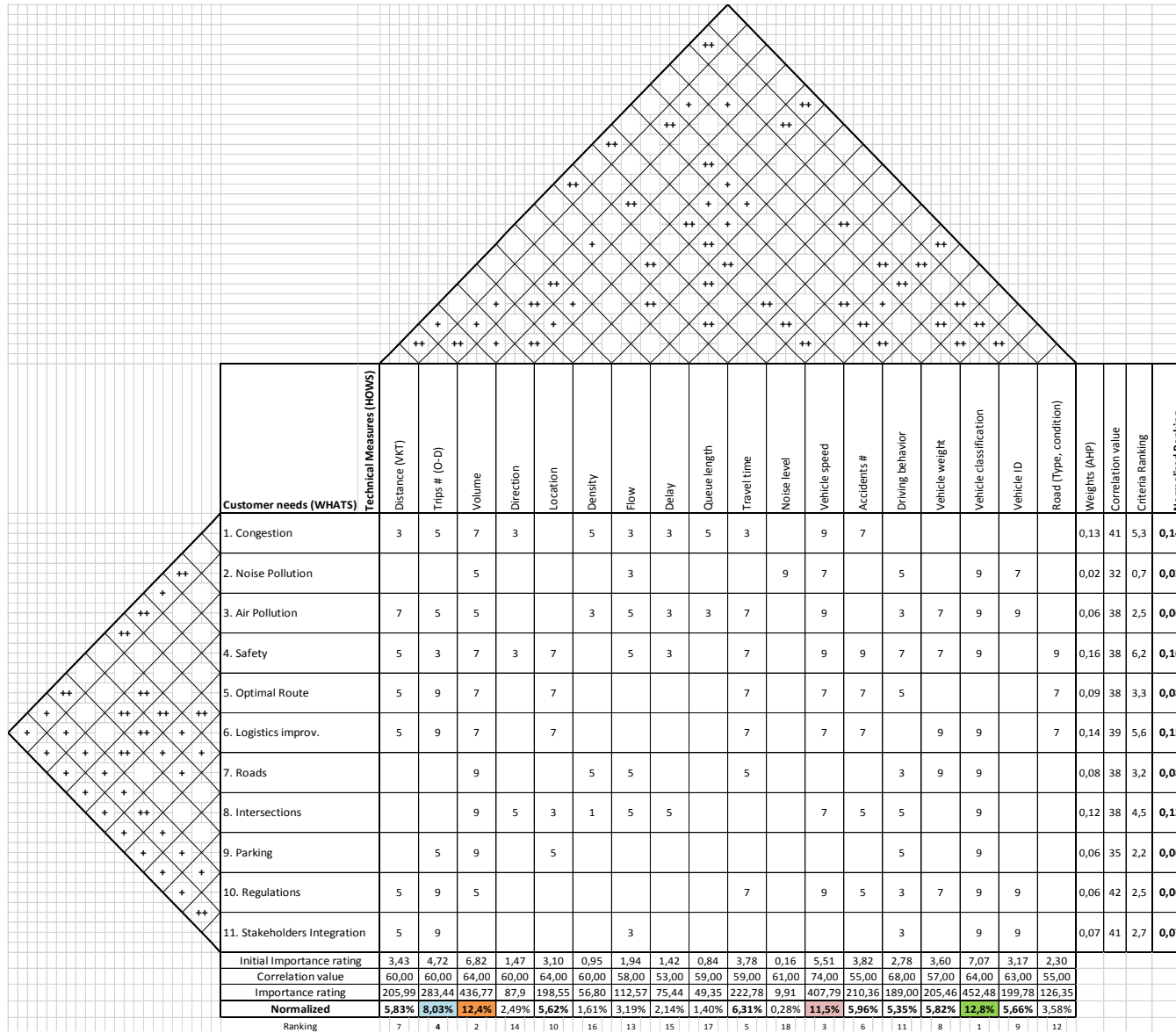

Figure 4-18 HOQ matrix (QFD phase I)

## A combined AHP and QFD methodology for data collection technique evaluation

QFD phase I results		Scenario 1		Scenario 2	
Ranking	Freight traffic data	Ranking	Traffic data	Ranking	Air pollution freight
1	Vehicle classification	1	Vehicle speed	1	Vehicle speed
2	Volume	2	Volume	2	Volume
3	Vehicle speed	3	Vehicle classification	3	Trips # (O-D)
4	Trips # (O-D)	4	Accidents	4	Vehicle classification
5	Travel time	5	Location	5	Vehicle ID
6	Accidents	6	Trips # (O-D)	6	Travel time
7	Vehicle weight	7	Driving behavior	7	Distance (VKT)
8	Distance (VKT)	8	Vehicle weight	8	Vehicle weight
9	Vehicle ID	9	Travel time	9	Accidents
10	Location	10	Distance (VKT)	10	Location
11	Driving behavior		Road condition		Driving behavior
12	Road condition		Flow		Queue length
13	Flow		Vehicle ID		Road condition
14	Direction		Direction		Density
15	Delay		Delay		Flow
16	Density		Density		Delay
17	Queue length		Queue length		Direction
18	Noise level		Noise level		Noise level

Figure 4-19 Traffic data ranking in different scenarios.

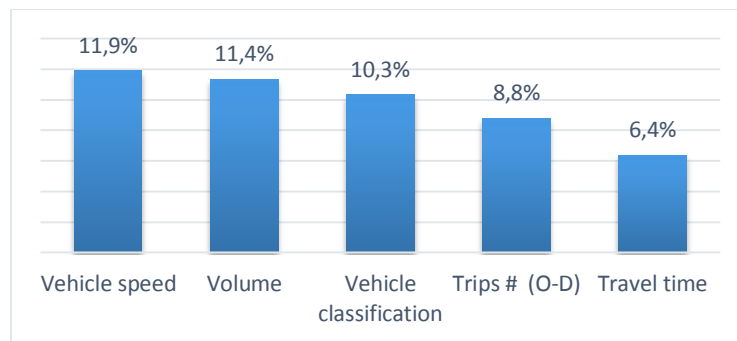

Figure 4-20 Top 5 traffic data

The top ranked traffic data match with the results of the most important freight traffic data for the freight sector of The Netherlands. The most important data according this scenario evaluation is speed. Speed is not only a raw data of some sensors, but can also be estimated with other data. Moreover, is a key data for many traffic related analysis. Volume ranks second, and is one of the most collected and utilized data worldwide. Volume is not only the input for data as flow or density, but also the main component for many traffic studies.

### QFD phase II.

A second HOQ is formed to relate the freight traffic data (WHATs) to the traffic data collection methods (HOWs). The QFD phase II HOQ matrix can be seen in figure 4-21. And the results obtained for the importance of traffic data collection methods are displayed in figure 4-22.

Two alternative scenarios are proposed to analyze the QFD phase II results:

**Scenario 1.** Using automatic video image processing. This gave less value to video image because their initial deployment cost increases and needs higher communication bandwidth.

This scenario resulted in the same ranking order of the QFD phase II original results. The only difference is that the weight of video sensors now very close to the third place (mobile-probe). Video sensors have a weight of 9.72% and mobile-probe 9.55%. Therefore are no longer a definitive second best option.

A combined AHP and QFD methodology for data collection technique evaluation

Customer needs (WHATS)	Technical Measures (HOWs)										Probe Vehicles				Normalized weights	
	Pneumatic road tubes	Piezoelectric sensors.	Inductive loop detectors (ILD).	Video image (+ Aerial surveys)	Magnetic sensors	Manual counts.	Infrared sensors.	Microwave radar.	Laser sensors	Acoustic sensors (+ Sonar, Ultrasonic)	Surveys	RFID	GPS	Mobile		Moving observer.
Distance (VKT)											5	1	9	1		0,06
Trips # (O-D)				6							5	1	9	1		0,10
Volume	5	4	6	7	6	5	7	5	6	5		1	1	1	3	0,12
Direction	4	3	5	7	5	4	6	6	6	4			9	9	3	0,02
Location	1	1	1	1	1	1	1	1	1	1	8	9	8	1		0,05
Density	1	1	1	1	1	1	1	1	1	1	1	1	1	1		0,02
Flow	1	1	1	1	1	1	1	1	1	1	1	1	1	1		0,03
Delay															3	0,02
Queue length			1	1				1	1	1	8	9	9			0,01
Travel time	1		1	6	1	1	1				5	1	9	9	2	0,06
Noise level										5						0,00
Vehicle speed	3	3	5	1	1	1	6	7	7	4	8	9	8	3		0,11
Accidents				7		4		6		5		1	9	3		0,06
Driving behavior			1	6							5		9	1		0,05
Vehicle weight		3	1	1												0,06
Vehicle classification	3	3	5	7	4	3	7	6	6	6	5		8	1	3	0,13
Vehicle ID				6	4						9	8	8			0,06
Road condition				7	4	4						1	1	3		0,03
Initial Importance rating	1,590	1,554	2,342	4,442	1,997	1,725	2,733	2,772	2,549	2,344	1,982	2,343	5,998	3,744	1,721	
Normalized	4,0%	3,90%	5,88%	11,15%	5,01%	4,33%	6,86%	6,96%	6,40%	5,88%	4,98%	5,88%	15,06%	9,40%	4,3%	
Ranking	14	15	7	2	10	12	5	4	6	8	11	9	1	3	13	

Figure 4-21 HOQ phase 2

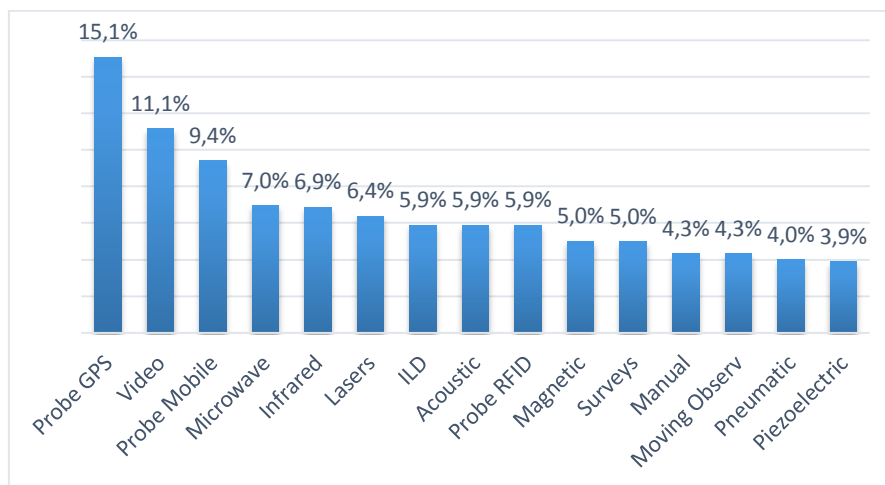

Figure 4-22 Traffic data collection methods ranking for Eindhoven

**Scenario 2.** Traffic data collection methods were evaluated without Eindhoven’s characteristics of rain, fog, ITS, and aesthetics.

Results of this scenario are similar than the results displayed in figure 4-22. The top 3 ranked methods are still GPS-probes, video sensors, and mobile-probes. However a notorious improvement is observed for acoustic sensors that become 4<sup>th</sup> in the ranking (see figure 4-23).

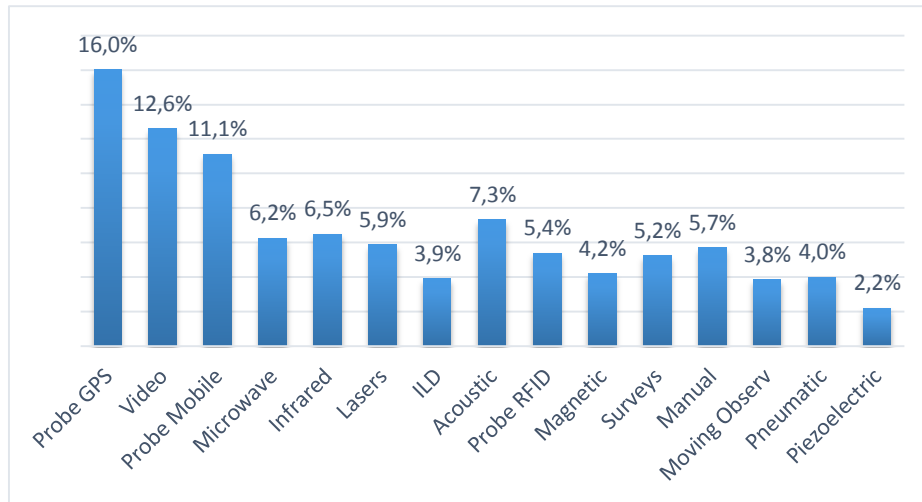

Figure 4-23 Traffic data collection methods general ranking

### Inferences from the QFD phase II.

The relationship matrix value assigned to probe vehicles in this HOQ matrix was higher than all other methods. This is because GPS and mobile probe vehicles outperform other sensors in the evaluated characteristics (maintenance, installation, and ITS). However, the main drawback of probe vehicles is their poor accuracy for collecting traffic volume data (2<sup>nd</sup> in the ranking). This could represent an important factor for authorities not adopting the method.

GPS and mobiles probes are also performing well in this analysis due their capacity to collect speed, classification and location data. The results obtained in phase I (figure 4-19) show that classification and speed are the 1<sup>st</sup> and 3<sup>rd</sup> most important freight traffic data. And even when this sensors are not accurate for traffic volume (2<sup>nd</sup> in the ranking), their accurate collection of location can calculate O-D and travel time. This two data are the 4<sup>th</sup> and 5<sup>th</sup> most important freight traffic data.

The best ranked traffic data collection method is GPS-based probes. Thus, the statistic of the distribution of GPS among vehicles in England between 2009 and 2013 is considered an indicator of the penetration of this sensors in the European market (see figure 4-24)

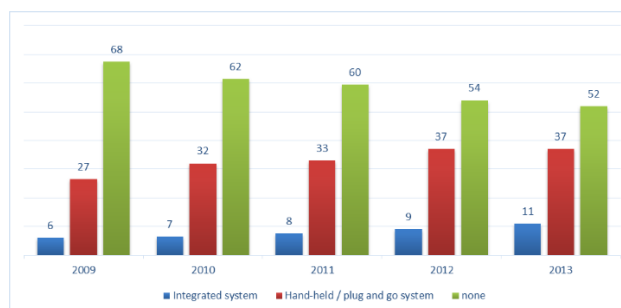

Figure 4-24 England 2009-2013 distribution (%) of GPS in vehicles (Statista, 2015)

The obtained results allow to propose GPS-probes, video sensors, and mobile-probes as adequate freight traffic data collection methods for Eindhoven. The AHP and QFD phase I have a national approach, but this second QFD phase niche the results to the city of Eindhoven.

## 4.5 Discussion

The obtained results support the hypothesis of this thesis. Probe vehicles (GPS-based) are the most adequate freight traffic data collection method for Eindhoven. Two characteristics of GPS probes that contribute to their selection are: real-time data and experience as dedicated fleets for monitoring HGVs. The strongest competitor against probe vehicles are the video image sensors. Video sensors are only outperformed by GPS-based probe vehicles. Thus, the results reject the secondary hypothesis of this thesis. ILD rank seventh among the methodologies to collect traffic data. Probe vehicles (GPS and mobile), video image, laser, microwave, and infrared sensors outperform ILD.

This research identifies traffic data collection methods available in the market. These methods are useful all over the world. The fifteen data collection methods selected are defined in section 3.1. The goal is to rank the methods according to their performance in Eindhoven. To achieve this, the second phase of the QFD takes into account Eindhoven characteristics (aesthetics, weather, and ITS). The identified traffic data is for all types of vehicles, but is selected because it can analyze and optimize the freight transport sector. The eighteen traffic data analyzed are defined in section 3.2. The first phase of the QFD methodology tackles the generalization of traffic data by ranking freight traffic data instead of general traffic data.

European studies are the main input for the literature review. Including studies from The Netherlands. However, some studies from this review are from continents different from Europe (e.g. U.S.A, Singapore, and India). The last is due to the general applicability of the traffic data and the traffic data collection methods. The aim is to identify the useful traffic data in The Netherlands. Thus, the AHP methodology only surveyed Dutch stakeholders from the freight transport sector. The surveys evaluated eleven freight traffic related problems originated from four urban development sectors. Results show that the most important problems associated to freight traffic are: safety risks, logistics inefficiency, and congestion.

The QFD methodology integrates the importance of urban transport problems and the freight traffic data. Then it ranks the methods to collect traffic data in Eindhoven. QFD considers general characteristics of the methods (accuracy, installation, and performance). The results show that the three most adequate methods for the city are: GPS-probes, video cameras, and mobile-probes. Microwave, infrared, and lasers sensors are the next methods in the ranking. The first three methods are proposed for an integrated real-time traffic monitoring system (ITS) in the city. This ITS could select GPS or mobile probes and combine it with video cameras that use manual data processing. The other three methods are only recommended for site specific and period-based traffic analyses.

In the past, Eindhoven has utilized ILD and video cameras to perform traffic counts. ILD are the next method in the ranking after laser sensors. Thus, they are not discarded as an option for traffic data collection. The existing ILD can become components of traffic data collection systems. However, their difficult and expensive installation discards their implementation in existing roads. ILD are only recommended when integrated in the construction of new roads.

### **Barriers for adoption**

Implementing new strategies always present difficulties for city administrators. They require extensive coordination, funding, and support across multiple stakeholders. Thus, some of the adoption barriers for the three recommended methods are:

- GPS-based probe vehicle: Low penetration of this technology in the total share of vehicles. In 2013 only 11% of the total vehicles of England had an integrated GPS and 37% vehicles had a GPS gadget.
- Video image sensors: Image processors represent a high initial investment. And manual processors represent a high operation and management cost.
- Mobile-based probe vehicles: High amount of data, high communication bandwidth required, lack of standardization, and privacy issues.

### **Limitations**

The low participation of the freight and retail sectors constrain the AHP results. A better representation of the stakeholder's interests could be achieved by leveling the amount of respondents of each stakeholder group and by increasing the participants' motivation for filling in the questionnaire. Also, a factor that would take into account the influence level of each stakeholder group in the decision-making process was not available. Moreover, the QFD matrix was filled in by the author of this thesis in his role of expert on traffic data collection. No group of experts in the subject was identified due time limitations.

This thesis proposes the combination of 2 methods to collect data based in an ITS. More information and research is needed to propose only one traffic data collection method. Information about: how the collected data will be analyzed, the type of traffic detection of interest (real-time or period-based), and the specific urban problem to analyze.

### **Further research.**

A cost/benefit analysis of each method is necessary to make a definitive method selection. The cost/ benefit analysis should include: market analysis, technical characteristics (including data processing), life expectancy, etc. Also more research should be done about the raw data processing of the traffic sensors. The performance and quality of obtained data depends much more on this than on the capabilities of the detector itself. Furthermore, probe vehicles need further research regarding the amount of data processed, algorithms, communication bandwidth, and the number of probes required for a good performance in the city of Eindhoven.

### **Recommendations**

Mobile-based probes. A standardized application (app) to access the cellphone data can be developed (supported by policy-makers). This app can ask for the consent of the user to access private information (location) and include security measures. If the users are willing to pay to get accurate real-time traffic information the application can generate profit.

GPS-based probes. Authorities together with car maker companies could create policies that increase the penetration of GPS in new vehicles.



GPS + mobile probes. Could be the best probe vehicle available in the market. This two probes have been combined in the past (Herrera et al., 2010). Authorities could support this by financing research about this relative new technology.

Video. The recommendation is for a high initial investment using automatic video image processing for real-time data monitoring (ITS). Or a lower initial investment, with more operation & management costs using a national TCC.

Microwave, infrared, and laser sensors. This techniques are not recommended for ITS systems. But their high rank in the evaluation (4<sup>th</sup>, 5<sup>th</sup>, and 6<sup>th</sup>) allow to recommend their joint deployment in a traffic data collection system.

This thesis opens the possibility of creating a case study in Eindhoven. The case study would test the best ranked methods of this thesis. This case study could also investigate the privacy and security issues of Float Car Data. Two scenarios for implementing this data collection methods in the city of Eindhoven are proposed in appendix 13.

Conclusion.

## 5 Conclusion.

### 5.1 Societal Relevance

There is a need for traffic information all over Europe. In the city of Eindhoven freight traffic data can contribute for a better urban transport management and planning. This research identifies GPS-based probe vehicles, video cameras, and mobile-based probe vehicles as the most adequate options for real-time freight traffic monitoring in the city of Eindhoven. Furthermore, video cameras and mobile-probes can also monitor bicycles, a traffic sector of particular importance in The Netherlands. This ITS sensors can assist authorities to make the city smarter, safer, and more sustainable. Nowadays ITS are being adopted all over Europe as smart solutions for urban planning.

This thesis integrate the opinion of five stakeholder groups of the freight transport in The Netherlands. This stakeholder integration creates a clear overview of the most concerning traffic related problems for Eindhoven and for the rest of the country. AHP results indicate that the most important freight traffic related problems for The Netherlands are safety risks, logistics inefficiency, and congestion.

### 5.2 Scientific Relevance

This research combines AHP and QFD for the first time in the freight traffic data collection niche of the transport sector. The traffic data collection methods are evaluated as part of a general solution for the problems of the urban transport sector. Different from studies done in the past that make this evaluation looking for the solution of a particular traffic problem.

The used methodology possess the transferable and scalable characteristics. The AHP questionnaire can be adapted to survey stakeholders of other traffic sector. Also the QFD can be used to prioritize other type of traffic data. This was exemplified by the scenarios performed for prioritizing air pollution related freight traffic data and the methods evaluation outside Eindhoven. This thesis can be seen as a basis for further research to identify an optimal traffic data collection method taking into account their technical specifications and a cost/benefit analysis.

### 5.3 Beneficiary Relevance

This investigation originated from the need of the Municipality of Eindhoven for obtaining traffic data. The policy-making department of the Municipality can use this framework as a decision-support tool. A tool that integrates the interests of different stakeholders in The Netherlands regarding traffic related issues. The advantage of this research is that can be adapted to specific analysis of interest. The obtained results identify three adequate traffic data collection methods for the city. The methods can also be used to evaluate the new policy measures and fulfill the decision-making feedback-loop.

A final method selection for implementation depends on the specific interests of the Municipality. A real-time traffic monitoring system or a location specific period-based traffic analysis. Also the available budget is important, although the contribution for a better quality of life for Dutch citizens should be prioritized in case that the technique represents a high investment.

Conclusion.

## References

- Ahmed, S., Hussain, T. M., & Saadawi, T. N. (1994). Active and passive infrared sensors for vehicular traffic control. *Vehicular Technology Conference*, 1393–1397. Retrieved from [http://ieeexplore.ieee.org/xpls/abs\\_all.jsp?arnumber=345323](http://ieeexplore.ieee.org/xpls/abs_all.jsp?arnumber=345323)
- Akao, Y. (1997). QFD: past, present, and future. *International Symposium on QFD*, 97(2), 1–12. Retrieved from <http://scholar.google.com/scholar?hl=en&btnG=Search&q=intitle:QFD:+Past,+Present,+and+Future#0>
- Ambrosino, G., Guerra, S., Pettinelli, I., & Sousa, C. (2014). The Role of Logistics Services in Smart Cities: the Experience of ENCLOSE Project. *Proceedings - REAL CORP*, 8, 1029–1034.
- Arentze, T., Feng, T., Timmermans, H., & Robroeks, J. (2012). Context-dependent influence of road attributes and pricing policies on route choice behavior of truck drivers: Results of a conjoint choice experiment. *Transportation*, 39(6), 1173–1188. doi:10.1007/s11116-012-9391-z
- Awasthi, A., & Chauhan, S. S. (2011). Using AHP and Dempster-Shafer theory for evaluating sustainable transport solutions. *Environmental Modelling and Software*, 26(6), 787–796. doi:10.1016/j.envsoft.2010.11.010
- Baldasano, J. M., Gonçalves, M., Soret, A., & Jiménez-Guerrero, P. (2010). Air pollution impacts of speed limitation measures in large cities: The need for improving traffic data in a metropolitan area. *Atmospheric Environment*, 44(25), 2997–3006. doi:10.1016/j.atmosenv.2010.05.013
- Barbagli, B., Manes, I. M. G., Manes, a., Langer, G., & Bacchi, M. (2010). A distributed sensor network for real-time acoustic traffic monitoring and early queue detection. *Proceedings - 4th International Conference on Sensor Technologies and Applications, SENSORCOMM 2010*, 173–178. doi:10.1109/SENSORCOMM.2010.102
- Bauza, R., & Gozalvez, J. (2013). Traffic congestion detection in large-scale scenarios using vehicle-to-vehicle communications. *Journal of Network and Computer Applications*, 36(5), 1295–1307. doi:10.1016/j.jnca.2012.02.007
- Beck, K. H., Yan, A. F., & Wang, M. Q. (2009). A comparison of web-based and telephone surveys for assessing traffic safety concerns, beliefs, and behaviors. *Journal of Safety Research*, 40(5), 377–381. doi:10.1016/j.jsr.2009.07.007
- Berkowicz, R., Winther, M., & Ketznel, M. (2006). Traffic pollution modelling and emission data. *Environmental Modelling and Software*, 21, 454–460. doi:10.1016/j.envsoft.2004.06.013

## References

- Bhattacharya, A., Geraghty, J., & Young, P. (2010). Supplier selection paradigm: An integrated hierarchical QFD methodology under multiple-criteria environment. *Applied Soft Computing Journal*, *10*(4), 1013–1027. doi:10.1016/j.asoc.2010.05.025
- Bifulco, G. N., Galante, F., Pariota, L., Russo Spena, M., & Del Gais, P. (2014). Data Collection for Traffic and Drivers' Behaviour Studies: A Large-scale Survey. *Procedia - Social and Behavioral Sciences*, *111*, 721–730. doi:10.1016/j.sbspro.2014.01.106
- Boogaard, H., Janssen, N. a H., Fischer, P. H., Kos, G. P. a, Weijers, E. P., Cassee, F. R., ... Hoek, G. (2012). Impact of low emission zones and local traffic policies on ambient air pollution concentrations. *The Science of the Total Environment*, *435-436*, 132–40. doi:10.1016/j.scitotenv.2012.06.089
- Borrego, C., Tchepel, O., Barros, N., & Miranda, a. I. (2000). Impact of road traffic emissions on air quality of the Lisbon region. *Atmospheric Environment*, *34*, 4683–4690. doi:10.1016/j.atmosenv.2003.09.004
- Boskovich, S., & Barth, M. (2013). Vehicular network rerouting autonomy with a V2V, I2V, and V2I communication matrix classification. *Proceedings of the 16th International IEEE Annual Conference on Intelligent Transportation Systems*, 172–177. doi:10.1109/ITSC.2013.6728229
- Browne, M., Allen, J., Nemoto, T., Patier, D., & Visser, J. (2012). Reducing social and environmental impacts of urban freight transport: A review of some major cities. *Procedia - Social and Behavioral Sciences*, *39*, 19–33. doi:10.1016/j.sbspro.2012.03.088
- Carrese, S., Mantovani, S., & Nigro, M. (2011). Safe, secure and comfortable HGVs parking areas: An Italian experience. *Procedia - Social and Behavioral Sciences*, *20*, 732–740. doi:10.1016/j.sbspro.2011.08.081
- Chan, L., & Wu, M.-L. (2005). A systematic approach to quality function deployment with a full illustrative example. *Omega*, *33*(2), 119–139. doi:10.1016/j.omega.2004.03.010
- Chan, L.-K., & Wu, M.-L. (2002). *Quality function deployment: A literature review*. *European Journal of Operational Research* (Vol. 143). doi:10.1016/S0377-2217(02)00178-9
- Cherrett, T., Allen, J., McLeod, F., Maynard, S., Hickford, A., & Browne, M. (2012). Understanding urban freight activity - key issues for freight planning. *Journal of Transport Geography*, *24*, 22–32. doi:10.1016/j.jtrangeo.2012.05.008
- Chourabi, H., Nam, T., Walker, S., Gil-Garcia, J. R., Mellouli, S., Nahon, K., ... Scholl, H. J. (2012). Understanding Smart Cities: An Integrative Framework. *45th Hawaii International Conference on System Sciences*, 2289–2297. doi:10.1109/HICSS.2012.615
- Chu, T., Wang, J., & Leckie, J. O. (2012). An Ontology-based Service Model for Smart Infrastructure Design. *International Conference on Cloud and Service Computing*, 17–24. doi:10.1109/CSC.2012.11

## References

- Clark, M. A. G., Kidson, P., & Hodge, A. (1990). INFRARED DETECTOR DEVELOPMENT. *Third International Conference on Road Traffic Control*, 158 – 162.
- Curry, B., & Davies, F. (1995). Chapter 2: The Analytic Hierarchy Process. In *Expert Choice, Inc. User manual: Ecpro for windows: Decision support software*. Pittsburgh, USA.
- Debnath, A. K., Chin, H. C., Haque, M. M., & Yuen, B. (2014). A methodological framework for benchmarking smart transport cities. *Cities*, 37, 47–56. doi:10.1016/j.cities.2013.11.004
- Ding, Y., Banitalebi, B., Miyaki, T., & Beigl, M. (2012). RFTraffic: Passive traffic awareness based on emitted RF noise from the vehicles. *EURASIP Journal on Wireless Communications and Networking*, 8(1), 1–14. doi:10.1109/ITST.2011.6060088
- Eichler, M., & Daganzo, C. F. (2006). Bus lanes with intermittent priority: Strategy formulae and an evaluation. *Transportation Research Part B: Methodological*, 40(9), 731–744. doi:10.1016/j.trb.2005.10.001
- Farkas, K., Nagy, A. Z., Tomás, T., & Szabó, R. (2014). Participatory Sensing Based Real-time Public Transport Information Service. *International Conference on Pervasive Computing and Communications Demonstrations*, 141–144.
- Feng, T., Arentze, T., & Timmermans, H. (2013). Capturing preference heterogeneity of truck drivers' route choice behavior with context effects using a latent class model. *European Journal of Transport and Infrastructure Research*, 13(4), 259–273.
- Findley, D. J., Cunningham, C. M., & Hummer, J. E. (2011). Comparison of mobile and manual data collection for roadway components. *Transportation Research Part C: Emerging Technologies*, 19(3), 521–540. doi:10.1016/j.trc.2010.08.002
- Fujiwara, A., & Zhang, J. (2013). *Sustainable Transport Studies in Asia*. (G. Meyer, Ed.). Tokyo: Springer Japan. doi:10.1007/978-4-431-54379-4 Springer
- Gajda, J., Piwowski, P., Sroka, R., Stencel, M., & Zeglen, T. (2012). Application of inductive loops as wheel detectors. *Transportation Research Part C: Emerging Technologies*, 21(1), 57–66. doi:10.1016/j.trc.2011.08.010
- Gann, D. M., Dodgson, M., & Bhardwaj, D. (2011). Physical–digital integration in city infrastructure. *IBM Journal of Research and Development*, 55(1 & 2), 8:1–8:10. doi:10.1147/JRD.2010.2095750
- Geng, Y., & Cassandras, C. G. (2012). A new “Smart Parking” System Infrastructure and Implementation. *Procedia - Social and Behavioral Sciences*, 54, 1278–1287. doi:10.1016/j.sbspro.2012.09.842
- Gentili, M., & Mirchandani, P. B. (2012). Locating sensors on traffic networks: Models, challenges and research opportunities. *Transportation Research Part C: Emerging Technologies*, 24, 227–255. doi:10.1016/j.trc.2012.01.004

## References

- Golla, P. R., Mukherjee, A., & Harvey, B. (2013). Extruded Segmented Sensor for Road Traffic Classification. *Proceedings of IEEE Southeastcon*, 1–5.
- Gongjun, Y., Olariu, S., & Popescu, D. (2012). NOTICE: An architecture for the notification of traffic incidents. *IEEE Intelligent Transportation Systems Magazine*, 4, 6–16. doi:10.1109/MITS.2012.2217571
- Govers, C. P. M. (1996). What and how about quality function deployment (QFD). *International Journal of Production Economics*, 46-47(95), 575–585. doi:10.1016/0925-5273(95)00113-1
- Hamra, W. El, & Attallah, Y. (2011). The role of vehicles' identification techniques in transportation planning - Modeling concept. *Alexandria Engineering Journal*, 50(4), 391–398. doi:10.1016/j.aej.2012.01.001
- Harlow, C., & Peng, S. (2001). Automatic vehicle classification system with range sensors. *Transportation Research Part C: Emerging Technologies*, 9(4), 231–247. doi:10.1016/S0968-090X(00)00034-6
- Harris, I., Wang, Y., & Wang, H. (2015). ICT in multimodal transport and technological trends: unleashing potential for the future. *International Journal of Production Economics*, 159, 88 – 103. doi:10.1016/j.ijpe.2014.09.005
- Herrera, J. C., Work, D. B., Herring, R., Ban, X., Jacobson, Q., & Bayen, A. M. (2010). Evaluation of traffic data obtained via GPS-enabled mobile phones: The Mobile Century field experiment. *Transportation Research Part C: Emerging Technologies*, 18(4), 568–583. doi:10.1016/j.trc.2009.10.006
- Ho, W., He, T., Lee, C. K. M., & Emrouznejad, A. (2012). Strategic logistics outsourcing: An integrated QFD and fuzzy AHP approach. *Expert Systems with Applications*, 39(12), 10841–10850. doi:10.1016/j.eswa.2012.03.009
- Hong, J., & Goodchild, A. (2014). Land use policies and transport emissions: Modeling the impact of trip speed, vehicle characteristics and residential location. *Transportation Research Part D: Transport and Environment*, 26, 47–51. doi:10.1016/j.trd.2013.10.011
- Hull, A. (2005). Integrated transport planning in the UK: From concept to reality. *Journal of Transport Geography*, 13(4), 318–328. doi:10.1016/j.jtrangeo.2004.12.002
- Ibeas, A., Moura, J. L., Nuzzolo, A., & Comi, A. (2012). Urban Freight Transport Demand: Transferability of Survey Results Analysis and Models. *Procedia - Social and Behavioral Sciences*, 54, 1068–1079. doi:10.1016/j.sbspro.2012.09.822
- Jamal, R., Manaa, K., Rabee'a, M., & Khalaf, L. (2015). Traffic control by digital imaging cameras. In *Emerging Trends in Image Processing, Computer Vision and Pattern Recognition* (pp. 161–182). Elsevier Inc. doi:10.1016/B978-0-12-802045-6.00011-9

## References

- Kaparias, I., Eden, N., Tsakarestos, A., Gal-Tzur, A., Gerstenberger, M., Hoadley, S., ... Bell, M. (2012). Development and Application of an Evaluation Framework for Urban Traffic Management and Intelligent Transport Systems. *Procedia - Social and Behavioral Sciences*, 48, 3102–3112. doi:10.1016/j.sbspro.2012.06.1276
- Kassomenos, P., Karakitsios, S., & Papaloukas, C. (2006). Estimation of daily traffic emissions in a South-European urban agglomeration during a workday. Evaluation of several “what if” scenarios. *Science of the Total Environment*, 370, 480–490. doi:10.1016/j.scitotenv.2006.08.018
- Kastrinaki, V., Zervakis, M., & Kalaitzakis, K. (2003). A survey of video processing techniques for traffic applications. *Image and Vision Computing*, 21(4), 359–381. doi:10.1016/S0262-8856(03)00004-0
- Klein, L. a, Mills, M. K., & Gibson, D. R. P. (2006). *Traffic Detector Handbook. Federal Highway Administration* (Vol. I). doi:FHWA-HRT-06-108 October
- Kumar, P., Nigam, S. P., & Kumar, N. (2014). Vehicular traffic noise modeling using artificial neural network approach. *Transportation Research Part C: Emerging Technologies*, 40, 111–122. doi:10.1016/j.trc.2014.01.006
- Kwong, K., Kavalier, R., Rajagopal, R., & Varaiya, P. (2009). Arterial travel time estimation based on vehicle re-identification using wireless magnetic sensors. *Transportation Research Part C: Emerging Technologies*, 17(6), 586–606. doi:10.1016/j.trc.2009.04.003
- Leduc, G. (2008). *Road Traffic Data : Collection Methods and Applications. JRC Technical Notes* (Vol. JRC 47967). doi:JRC 47967 - 2008
- Leonardi, J., Browne, M., Allen, J., Bohne, S., & Ruesch, M. (2014). Best Practice Factory for Freight Transport in Europe: Demonstrating how “Good” Urban Freight Cases are Improving Business Profit and Public Sectors Benefits. *Procedia - Social and Behavioral Sciences*, 125, 84–98. doi:10.1016/j.sbspro.2014.01.1458
- Liao, C.-N., & Kao, H.-P. (2014). An evaluation approach to logistics service using fuzzy theory, quality function development and goal programming. *Computers & Industrial Engineering*, 68, 54–64. doi:10.1016/j.cie.2013.12.001
- Liu, Y. L., Ge, Y. E., & Gao, H. O. (2014). Improving estimates of transportation emissions: Modeling hourly truck traffic using period-based car volume data. *Transportation Research Part D: Transport and Environment*, 26, 32–41. doi:10.1016/j.trd.2013.10.007
- Lopes, J., Bento, J., Huang, E., Antoniou, C., & Ben-Akiva, M. (2010). Traffic and Mobility Data Collection for Real- Time Applications. *13th International IEEE Conference on Intelligent Transportation Systems*, 8, 216–223. Retrieved from [http://ieeexplore.ieee.org/xpls/abs\\_all.jsp?arnumber=5625282](http://ieeexplore.ieee.org/xpls/abs_all.jsp?arnumber=5625282)



## References

- Lopez-ruiz, H. G., Christidis, P., Demirel, H., & Kompil, M. (2013). *Quantifying the Effects of Sustainable Urban Mobility Plans Third Main Title Line Third Line*. Luxembourg: Publications Office of the European Union. doi:10.2791/21875
- Lozano, A., Granados, F., & Guzmán, A. (2014). Impacts of modifications on urban road infrastructure and traffic management: a case study. *Procedia - Social and Behavioral Sciences*, 162, 368–377. doi:10.1016/j.sbspro.2014.12.218
- Maia, L. C., & do Couto, A. F. (2013). An innovative freight traffic assignment model for multimodal networks. *Computers in Industry*, 64(2), 121–127. doi:10.1016/j.compind.2012.10.011
- Marchesini, P., & Weijermars, W. (2010). The relationship between road safety and congestion on motorways. *SWOV Institute for Road Safety Research*, 28.
- Mcgowen, P., & Sanderson, M. (2011). Accuracy of Pneumatic Road Tube Counters. *Western District Annual Meeting Institute of Transportation Engineers Anchorage, AK*, (May).
- McKinnon, A. C. (2005). The economic and environmental benefits of increasing maximum truck weight: The British experience. *Transportation Research Part D: Transport and Environment*, 10(1), 77–95. doi:10.1016/j.trd.2004.09.006
- Mirchandani, P. B., Gentili, M., & He, Y. (2009). Location of vehicle identification sensors to monitor travel-time performance. *IET Intelligent Transport Systems*, 3(3), 289. doi:10.1049/iet-its.2008.0074
- Moriarty, P., & Honnery, D. (2013). Greening passenger transport: a review. *Journal of Cleaner Production*, 54, 14–22. doi:10.1016/j.jclepro.2013.04.008
- Naphade, M., Banavar, G., Harrison, C., Paraszczak, J., & Morris, R. (2011). Smarter Cities and Their Innovation Challenges. *Computer*, 44(6), 32–39.
- Neirotti, P., De Marco, A., Cagliano, A. C., Mangano, G., & Scorrano, F. (2014). Current trends in smart city initiatives: Some stylised facts. *Cities*, 38, 25–36. doi:10.1016/j.cities.2013.12.010
- Nguyen, V. C., Dinh, D. K., Le, V. A., & Nguyen, V. D. (2014). Length and Speed Detection Using Microwave Motion Sensor. *The 2014 International Conference on Advanced Technologies for Communications (ATC'14) Length*, 371–376.
- Nosal, K., & Solecka, K. (2014). Application of AHP method for multi-criteria evaluation of variants of the integration of urban public transport. *Transportation Research Procedia*, 3, 269–278. doi:10.1016/j.trpro.2014.10.006
- Ntalampiras, S. (2014). Universal background modeling for acoustic surveillance of urban traffic. *Digital Signal Processing: A Review Journal*, 31, 69–78. doi:10.1016/j.dsp.2014.05.003

## References

- Nuzzolo, A., & Comi, A. (2014). Sustainable Urban Logistics: Concepts, Methods and Information Systems. doi:10.1007/978-3-642-31788-0
- Pandian, S., Gokhale, S., & Ghoshal, A. K. (2009). Evaluating effects of traffic and vehicle characteristics on vehicular emissions near traffic intersections. *Transportation Research Part D: Transport and Environment*, 14(3), 180–196. doi:10.1016/j.trd.2008.12.001
- Park, S., Pil Hwang, J., Kim, E., & Kang, H.-J. (2010). Vehicle tracking using a microwave radar for situation awareness. *Control Engineering Practice*, 18(4), 383–395. doi:10.1016/j.conengprac.2009.12.006
- Peng, J. (2012). Selection of Logistics Outsourcing Service Suppliers Based on AHP. *Energy Procedia*, 17, 595–601. doi:10.1016/j.egypro.2012.02.141
- Pentikousis, K., Zhu, D., & Wang, H. (2011). Network infrastructure at the crossroads: The emergence of smart cities. *15th International Conference on Intelligence in Next Generation Networks*, 109–114. doi:10.1109/ICIN.2011.6081056
- Pirrerá, S., De Valck, E., & Cluydts, R. (2014). Field study on the impact of nocturnal road traffic noise on sleep: The importance of in- and outdoor noise assessment, the bedroom location and nighttime noise disturbances. *Science of The Total Environment*, 500-501, 84–90. doi:10.1016/j.scitotenv.2014.08.061
- Placzek, B. (2012). Selective data collection in vehicular networks for traffic control applications. *Transportation Research Part C: Emerging Technologies*, 23, 14–28. doi:10.1016/j.trc.2011.12.007
- Purson, E., Klein, E., Bacelar, A., Reclus, F., & Levilly, B. (2015). Simultaneous Assessments of Innovative Traffic Data Collection Technologies for Travel Times Calculation on the East Ring Road of Lyon. *Transportation Research Procedia*, 6, 79–89. doi:10.1016/j.trpro.2015.03.007
- Quintero, A., Konaré, D., & Pierre, S. (2005). Prototyping an intelligent decision support system for improving urban infrastructures management. *European Journal of Operational Research*, 162, 654–672. doi:10.1016/j.ejor.2003.10.019
- Quiroga, C. A. (2000). Performance measures and data requirements for congestion management systems. *Transportation Research Part C: Emerging Technologies*, 8, 287–306. doi:10.1016/S0968-090X(00)00008-5
- Raphiphan, P., Zaslavsky, A., & Indrawan-Santiago, M. (2014). Building Knowledge from Social Networks on What is Important to Drivers in Constrained Road Infrastructure. *Procedia Computer Science*, 35, 720–729. doi:10.1016/j.procs.2014.08.154
- Roscía, M., Michela, L., & Lazaroiu, G. C. (2013). Smart City By Multi-Agent Systems. *International Conference on Renewable Energy Research and Applications*, (October), 20–23.

## References

- Russo, F., & Comi, A. (2010). A classification of city logistics measures and connected impacts. *Procedia - Social and Behavioral Sciences*, 2(3), 6355–6365. doi:10.1016/j.sbspro.2010.04.044
- Russo, F., & Comi, A. (2011). Urban freight transport measures: environmental evidences from the cities. *1st World Sustainability Forum*, 1, 1–14.
- Saaty, T. L. (1980). The Analytic Hierarchy Process. *Education*, 1–11. Retrieved from <http://www.mendeley.com/research/the-analytic-hierarchy-process/>
- Saaty, T. L. (2004). Decision making — the Analytic Hierarchy and Network Processes (AHP/ANP). *Journal of Systems Science and Systems Engineering*, 13(1), 1–35. doi:10.1007/s11518-006-0151-5
- Santos, G., Behrendt, H., & Teytelboym, A. (2010). Part II: Policy instruments for sustainable road transport. *Research in Transportation Economics*, 28(1), 46–91. doi:10.1016/j.retrec.2010.03.002
- Sanwal, K. K., & Walrand, J. (1995). *Vehicles as Probes. California PATH Working Paper UCB-ITS-PWP-95-11.*
- Sattayaprasert, W., Hanaoka, S., Taneerananon, P., & Pradhananga, R. (2008). Creating a Risk-Based Network for Hazmat Logistics By Route Prioritization With Ahp. *International Association of Traffic and Safety Sciences*, 32(1), 74–87. doi:10.1016/S0386-1112(14)60202-8
- Schilk, G., & Seemann, L. (2012). Use of ITS Technologies for Multimodal Transport Operations – River Information Services (RIS) Transport Logistics Services. *Procedia - Social and Behavioral Sciences*, 48, 622–631. doi:10.1016/j.sbspro.2012.06.1040
- Sekimoto, Y., Watanabe, A., Nakamura, T., Kanasugi, H., & Usui, T. (2013). Combination of spatio-temporal correction methods using traffic survey data for reconstruction of people flow. *Pervasive and Mobile Computing*, 9(5), 629–642. doi:10.1016/j.pmcj.2012.10.005
- Smit, R., Ntziachristos, L., & Boulter, P. (2010). Validation of road vehicle and traffic emission models - A review and meta-analysis. *Atmospheric Environment*, 44(25), 2943–2953. doi:10.1016/j.atmosenv.2010.05.022
- Sohn, S. Y. (1999). Quality function deployment applied to local traffic accident reduction. *Accident Analysis and Prevention*, 31, 751–761. doi:10.1016/S0001-4575(99)00038-X
- Son, H. D., Kweon, Y. J., & Park, B. B. (2011). Development of crash prediction models with individual vehicular data. *Transportation Research Part C: Emerging Technologies*, 19, 1353–1363. doi:10.1016/j.trc.2011.03.002

## References

- Stanczyk, D., & Klein, E. (2012). Heavy Traffic Data Collection and Detection of Overloaded HGV. *Procedia - Social and Behavioral Sciences*, 48, 133–143. doi:10.1016/j.sbspro.2012.06.994
- Statista. (2015). *The Statistics Portal*. Retrieved July 01, 2015, from <http://www.statista.com/statistics/315395/distribution-of-vehicles-with-gps-in-england-united-kingdom/>
- Sternberg, H., & Andersson, M. (2014). Decentralized intelligence in freight transport—A critical review. *Computers in Industry*, 65(2), 306–313. doi:10.1016/j.compind.2013.11.011
- Syed, W. H., Yasar, A., Janssens, D., & Wets, G. (2014). Analyzing the Real Time Factors: Which Causing the Traffic Congestions and Proposing the Solution for Pakistani City. *Procedia - Procedia Computer Science*, 32, 413–420. doi:10.1016/j.procs.2014.05.442
- Szabo, R., Farkas, K., Ispany, M., Benczur, A. A., Batfai, N., Jeszenszky, P., ... Feher, G. (2013). Framework for Smart City Applications Based on Participatory Sensing. *International Conference on Cognitive Infocommunications*, 295–300.
- Tai, J. C., Tseng, S. T., Lin, C. P., & Song, K. T. (2004). Real-time image tracking for automatic traffic monitoring and enforcement applications. *Image and Vision Computing*, 22(6), 485–501. doi:10.1016/j.imavis.2003.12.001
- Tayahi, M. B., Johnson, B., Holtzman, M., & Cadet, G. (2005). Piezoelectric materials for powering remote sensors. *24th IEEE International Performance, Computing, and Communications Conference, PCCC*, 383–386. doi:10.1109/PCCC.2005.1460592
- Taylor, M. a P., Woolley, J. E., & Zito, R. (2000). Integration of the global positioning system and geographical information systems for traffic congestion studies. *Transportation Research Part C*, 8, 257–285. doi:10.1016/S0968-090X(00)00015-2
- Temponi, C., Yen, J., & Tiao, W. A. (1999). House of quality: A fuzzy logic-based requirements analysis. *European Journal of Operational Research*, 117(2), 340–354. doi:10.1016/S0377-2217(98)00275-6
- Thajchayapong, S., Garcia-Trevino, E. S., & Barria, J. A. (2013). Distributed classification of traffic anomalies using microscopic traffic variables. *IEEE Transactions on Intelligent Transportation Systems*, 14(1), 448–458. doi:10.1109/TITS.2012.2220964
- Tropartz, S., Horber, E., & Gruner, K. (1999). Experiences and results from vehicle classification using infrared overhead laser sensors at toll plazas in New York City. *Proceedings - International Conference on Intelligent Transportation Systems*, 686–691. doi:10.1109/ITSC.1999.821144
- Turner, S., Eisele, W., Benz, R., & Holdener, D. (1998). Travel time data collection handbook. *Fhwa*, (March). Retrieved from <http://trid.trb.org/view.aspx?id=497690>

## References

- U.S. Department of Transportation . (2015, May 20). *Policy and Government affairs. Highway Performance Monitoring System (HPMS)*. Retrieved from Federal Highway Administration: <http://www.fhwa.dot.gov/policyinformation/hpms/fieldmanual/>
- Vaqar, S. a., & Basir, O. (2009). Traffic pattern detection in a partially deployed vehicular Ad Hoc network of vehicles. *IEEE Wireless Communications*, 16(December), 40–46. doi:10.1109/MWC.2009.5361177
- Várhelyi, A. (2002). The effects of small roundabouts on emissions and fuel consumption: a case study. *Transportation Research*, 7, 65–71.
- Vermeulen, B., Goos, P., & Vandebroek, M. (2011). Rank-order choice-based conjoint experiments: Efficiency and design. *Journal of Statistical Planning and Inference*, 141(8), 2519–2531. doi:10.1016/j.jspi.2011.01.019
- Villanueva, F. J., Albusac, J., Jimenez, L., Villa, D., & Lopez, J. C. (2013). Architecture for Smart Highway Real Time Monitoring. *27th International Conference on Advanced Information Networking and Applications Workshops*, 1277–1282. doi:10.1109/WAINA.2013.55
- Wang, J. (1992). The Road Traffic Microwave Sensor (RTMS). *The 3rd International Conference on Vehicle Navigation and Information Systems*, 83–90.
- Wang, K., Tong, S., Roucoules, L., & Eynard, B. (2008). Analysis of consumers' requirements for data/information quality by using HOQ. *2008 IEEE International Conference on Industrial Engineering and Engineering Management, IEEM 2008*, 213–217. doi:10.1109/IEEM.2008.4737862
- Wang, Y., Coppola, P., Tzimitsi, A., Messmer, A., Papageorgiou, M., & Nuzzolo, A. (2011). Real-Time Freeway Network Traffic Surveillance: Large-Scale Field-Testing Results in Southern Italy. *IEEE Transactions on Intelligent Transportation Systems*, 12(2), 548–562. doi:10.1109/TCST.2005.859636
- Warriach, E. U., & Claudel, C. (2013). Poster Abstract : A Machine Learning Approach for Vehicle Classification using Passive Infrared and Ultrasonic Sensors. *ACM/IEEE International Conference on Information Processing in Sensor Networks (IPSN)*, 333–334.
- Weil, R., Wootton, J., & García-Ortiz, a. (1998). Traffic incident detection: Sensors and algorithms. *Mathematical and Computer Modelling*, 27(9-11), 257–291. doi:10.1016/S0895-7177(98)00064-8
- Wen, W. (2010). An intelligent traffic management expert system with RFID technology. *Expert Systems with Applications*, 37(4), 3024–3035. doi:10.1016/j.eswa.2009.09.030
- Wu, A., & Yang, X. (2013). Real-time Queue Length Estimation of Signalized Intersections Based on RFID Data. *Procedia - Social and Behavioral Sciences*, 96, 1477–1484. doi:10.1016/j.sbspro.2013.08.168

## References

- Yu, J., Wang, L., & Gong, X. (2013). Study on the Status Evaluation of Urban Road Intersections Traffic Congestion Base on AHP-TOPSIS Modal. *Procedia - Social and Behavioral Sciences*, 96, 609–616. doi:10.1016/j.sbspro.2013.08.071
- Zhang, Y., Yao, D., Qiu, T. Z., Peng, L., & Zhang, Y. (2012). Pedestrian Safety Analysis in Mixed Traffic Conditions Using Video Data. *IEEE TRANSACTIONS ON INTELLIGENT TRANSPORTATION SYSTEMS*, 13(4), 1832–1844.
- Zheng, P., & Mike, M. (2012). An Investigation on the Manual Traffic Count Accuracy. *Procedia - Social and Behavioral Sciences*, 43, 226–231. doi:10.1016/j.sbspro.2012.04.095
- Zhenshan, L. I., Jianqun, W., Xuejun, R. a N., & Guozhong, Y. a O. (2010). Traffic Information Extraction of Vehicle Acoustic Signal Based on Wavelet Packet Analysis. *Proceedings of the 29th Chinese Control Conference*, 2, 5438–5440.
- Zhu, Y., Liu, X., Li, M., & Zhang, Q. (2013). POVA: Traffic light sensing with probe vehicles. *IEEE Transactions on Parallel and Distributed Systems*, 24(7), 1390–1400. doi:10.1109/TPDS.2012.233
- Zimmermann, T., Wirtz, H., Puñal, O., & Wehrle, K. (2014). Analyzing Metropolitan-area Networking within Public Transportation Systems for Smart City Applications. *6th International Conference on New Technologies, Mobility and Security (NTMS)*, 1–5.
- Županović, D., Grgurević, I., & Filipčić, T. (2008). Importance of collecting and analyzing data on traffic flow load in urban environments. *Proceedings of the International Conference on Information Technology Interfaces, ITI*, 809–813. doi:10.1109/ITI.2008.4588515

References

Appendices

**APPENDIX 1. VEHICLE CLASSIFICATION SCHEMES (UNECE AND FHWA)**

In Europe, the classifications for vehicle category are based in UNECE standards and defined by the Commission Directive 2001/116/EC of 20 December 2001 and Directive 2002/24/EC of 18 March 2002. (European Union Directives, 2015). The EU general classification for motor vehicles with at least four wheels is:

**Category M: used for the carriage of passengers**

Category M1: no more than eight seats in addition to the driver seat (mainly, cars).

More than eight seats in addition to the driver seat (buses)

Category M2: having a maximum mass not exceeding 5 tonnes.

Category M3: having a maximum mass exceeding 5 tonnes.

**Category N: used for the carriage of goods (trucks)**

Category N1: having a maximum mass **not** exceeding 3.5 tonnes.

Category N2: having a maximum mass exceeding 3.5 tonnes but not exceeding 12 tonnes.

Category N3: having a maximum mass exceeding 12 tonnes.

**Category O: trailers (including semi-trailers)**

Category O1: maximum mass not exceeding 0.75 tonnes.

Category O2: exceeding 0.75 tonnes but not exceeding 3.5 tonnes.

Category O3: exceeding 3.5 tonnes but not exceeding 10 tonnes.

Category O4: exceeding 10 tonnes.

In the United States of America, the vehicle classifications are regulated by the Federal Highway Agency (FHWA) (see figure A-1)

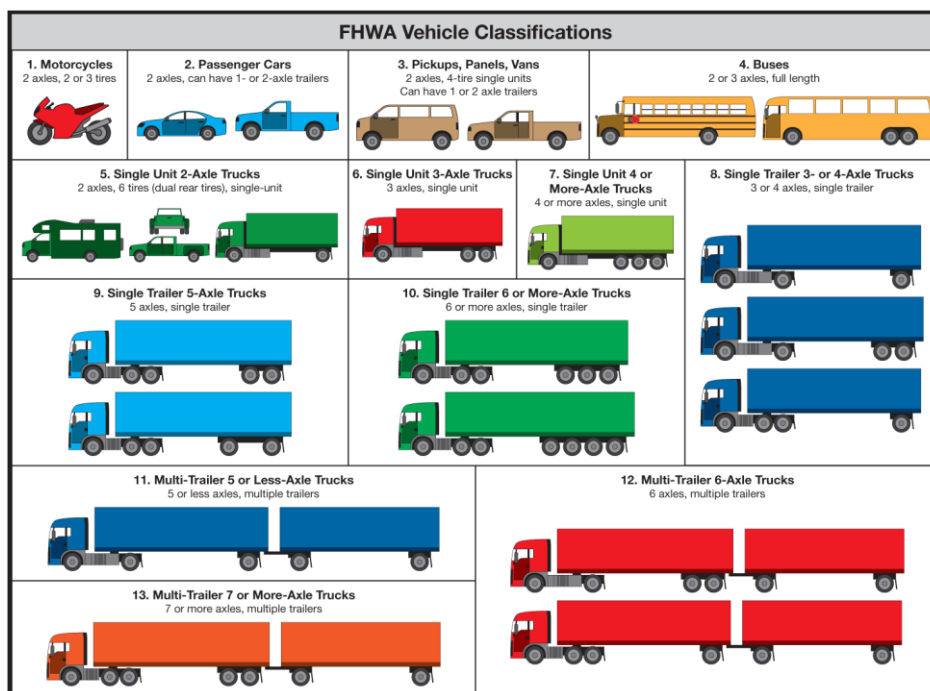

Figure A-1 Highway Performance Monitoring System classification (U.S. Department of Transportation , 2015)



**APPENDIX 2. LITERATURE REVIEW OF TRAFFIC DATA**

Traffic data and urban transport development sectors - literature review

Sub criteria	Data feeding the criteria	Reference
<b>1. Congestion</b>	Vehicle kilometers travelled ( <b>VKT</b> )	(Browne et al., 2012)
	<b>Journeys</b> travelled	
	<b>Volume</b> /capacity ratio	(Quiroga, 2000)
	<b>Density</b> of vehicles	(Raphiphan et al., 2014)
	Traffic <b>density</b>	(Wang et al., 2011)
	Average intersection <b>Delay</b> (LoS)	(Quiroga, 2000)
	Lane occupancy - <b>Direction</b>	(Quiroga, 2000)
	Travel <b>time</b>	(Quiroga, 2000)
	Travel <b>Time</b>	(Turner et al., 1998)
	<b>Flow</b>	(Turner et al., 1998)
	Queue <b>length</b> ,	(Quiroga, 2000)
	Travel <b>speed</b> ,	(Quiroga, 2000)
	Travel <b>speed</b> ,	(Wang et al., 2011)
	Traffic <b>incidents</b>	(Raphiphan et al., 2014)
<b>2. Noise pollution</b>	Average vehicle <b>speed</b>	(Kumar et al., 2014)
	Traffic <b>flow</b>	
	<b>Volume</b>	
	<b>Vehicle type</b> ( % HGV)	
	<b>Noise</b> monitoring	
	<b>Noise levels</b>	(Pirrera et al., 2014)
	<b>Journeys</b> travelled	(Browne et al., 2012)
	<b>Vehicle ID</b> (design)	
	<b>Driver behavior</b>	
<b>3. Air pollution</b>	<b>Distance</b> (VKT)	(Browne et al., 2012)
	<b>Distance</b> (VKT)	(Smit et al., 2010)
	<b>Distance</b> (VMT)	(Liu et al., 2014)
	<b>Vehicle ID</b> (fuel per km)	(Browne et al., 2012)
	<b>Vehicle ID</b> (fuel per km)	(Smit et al., 2010)
	<b>Journeys</b> travelled	(Browne et al., 2012)
	Vehicle routes - <b>Direction</b>	(Hong & Goodchild, 2014)
	Vehicle <b>speed</b>	(Kassomenos et al., 2006)
	Average <b>speed</b>	(Baldasano et al., 2010)
	Average <b>speed</b> ,	(Smit et al., 2010)
	Traffic <b>speed</b> .	(Fujiwara & Zhang, 2013)
	Travel <b>speed</b>	(Liu et al., 2014)
	<b>Speed</b>	(Pandian et al., 2009)
	Traffic <b>flow</b>	(Kassomenos et al., 2006)
	Traffic <b>flow</b>	(Smit et al., 2010)
	Traffic <b>volume</b>	(Kassomenos et al., 2006)
	<b>Volume</b> (AADT)	(Baldasano et al., 2010)

	Traffic <b>volume</b>	(Fujiwara & Zhang, 2013)
	<b>Volume</b> (AADT)	(Borrego et al., 2000)
	Traffic <b>volume</b>	(Liu et al., 2014)
	Traffic <b>density</b>	(Smit et al., 2010)
	<b>Queue</b> length	(Smit et al., 2010)
	<b>Road characteristics</b> (length, type, circulation zones)	(Baldasano et al., 2010)
	<b>Road characteristics</b> (length, type, circulation zones)	(Hong & Goodchild, 2014)
	<b>Road characteristics</b> (segment length, road classes)	(Borrego et al., 2000)
	<b>Road characteristics</b> (intersections)	(Pandian et al., 2009)
	<b>Travel Time</b>	(Smit et al., 2010)
	<b>Travel Time</b>	(Turner et al., 1998)
	<b>Driving behavior</b> (idle, acceleration, deceleration, cruise)	(Smit et al., 2010)
	<b>Driving behavior</b> (speed limits)	(Pandian et al., 2009)
	Intersection - <b>Delay</b>	(Pandian et al., 2009)
	<b>Vehicle type</b> (fuel consumption, vehicles type)	(Borrego et al., 2000)
	<b>Vehicle characteristics</b> (type)	(Liu et al., 2014)
	<b>Vehicle characteristics</b> (type)	(Pandian et al., 2009)
<b>4. Safety</b>	<b>Distance</b> (VKT)	(Browne et al., 2012)
	<b>Journeys (O-D)</b> travelled	(Browne et al., 2012)
	<b>Driving behavior</b>	(Browne et al., 2012)
	Lane-change & deceleration - <b>driving behavior</b>	(Thajchayapong et al., 2013)
	<b>Vehicle ID</b> (design)	(Browne et al., 2012)
	<b>Vehicle Type</b>	(Gongjun et al., 2012)
	<b>Traffic flow</b>	(Zhang et al., 2012)
	<b>Traffic flow</b>	(Wang et al., 2011)
	<b>Traffic Speed</b>	(Zhang et al., 2012)
	<b>Traffic Speed</b>	(Wang et al., 2011)
	Relative <b>speed</b>	(Thajchayapong et al., 2013)
	<b>Speed</b>	(Mcgowen & Sanderson, 2011)
	<b>Speed</b>	(Son et al., 2011)
	<b>Road characteristics</b> (geometric)	(Zhang et al., 2012)
	<b>Road characteristics</b> (Road surface state)	(Leduc, 2008)
	<b>Vehicle location</b> (gap spacing)	(Zhang et al., 2012)
	Position - <b>Location</b>	(Wang et al., 2011)
	Inter-vehicle spacing- <b>location</b>	(Thajchayapong et al., 2013)
	<b>Travel Time</b>	(Zhang et al., 2012)
	<b>Time - stamp</b>	(Wang et al., 2011)
	<b>Travel Time</b>	(Turner et al., 1998)
	Inter-vehicle time gap - <b>delay</b>	(Thajchayapong et al., 2013)
	Time headway - <b>Delay</b>	(Son et al., 2011)

	<b>Incidents</b>	(Wang et al., 2011)
	Crash data - <b>Incidents</b>	(Son et al., 2011)
	Crash data - <b>Incidents</b> (construction, accident, protest rally)	(Raphiphan et al., 2014)
	<b>Direction</b>	(Zhang et al., 2012)
	<b>Volume</b>	(MCGOWEN & SANDERSON, 2011)
<b>5. Optimal Route</b>	Vehicle <b>speed</b>	(Syed et al., 2014)
	Car <b>speed</b>	(Leduc, 2008)
	Vehicle <b>speed</b>	(Gongjun et al., 2012)
	Vehicle <b>speed</b>	(Bauza & Gozalvez, 2013)
	<b>Road characteristics</b>	(Syed et al., 2014)
	Car <b>location</b>	(Leduc, 2008)
	<b>Vehicle location</b>	(Gongjun et al., 2012)
	<b>Vehicle location</b> (position)	(Bauza & Gozalvez, 2013)
	Car <b>direction</b> of travel	(Leduc, 2008)
	Travel <b>Distance</b>	(Lujak et al., 2015)
	<b>Trip</b> (O-D route)	(Lujak et al., 2015)
	Annual <b>volume</b> of truck traffic	(McKinnon, 2005)
	Vehicle <b>Accidents</b>	(Gongjun et al., 2012)
	<b>Time</b>	(Gongjun et al., 2012)
	Travel <b>Time</b>	(Turner et al., 1998)
<b>Driver behavior</b> (Driver's route choices, mood)	(Bifulco et al., 2014)	
<b>6. Improving logistics</b>	Travel <b>Time</b>	(Turner et al., 1998)
	Travel <b>Time</b>	(Maia & do Couto, 2013)
	Vehicle <b>Type</b> (Length & Capacity )	(Maia & do Couto, 2013)
	Travel <b>Distance</b>	(Maia & do Couto, 2013)
	Travel <b>Distance</b> (Truck kms)	(McKinnon, 2005)
	<b>Trips</b>	(McKinnon, 2005)
	Annual <b>volume</b> of truck traffic	(McKinnon, 2005)
	Vehicle <b>Speed</b>	(McKinnon, 2005)
	Vehicle <b>Weight</b> (Capacity)	(McKinnon, 2005)
Traffic <b>incidents</b>	(McKinnon, 2005)	
<b>7. Roads</b>	<b>Driver Behavior</b> (Passenger Flow)	(Quiroga, 2000)
	<b>Traffic density</b>	Highway design manual
	<b>Road Characteristics</b>	Highway design manual
	<b>Vehicle Speed</b>	Highway design manual
	<b>Vehicle Type</b>	Highway design manual
	<b>Vehicle Weight</b>	Highway design manual
	Design Volume = Volume per hour ( <b>Flow</b> )	Highway design manual
	Travel <b>Time</b>	(Turner et al., 1998)
	AADT - <b>Volume</b>	(Leduc, 2008).
	<b>Volume</b>	(MCGOWEN & SANDERSON, 2011)
	Annual growth - <b>Volume</b>	(Županović et al., 2008).

	Transport growth forecasting - <b>volume</b>	(Santos et al., 2010)
<b>8. Intersections</b>	<b>Road Characteristics</b> (Traffic light sensing )	(Zhu et al., 2013)
	Real-time state of <b>position</b>	(Zhu et al., 2013)
	Real-time state of <b>speed</b>	(Zhu et al., 2013)
	Turning movement counts - <b>Direction</b>	(Taylor et al., 2000)
	<b>Volume</b>	(Mcgowen & Sanderson, 2011)
	Traffic load (per lane) - <b>density</b>	(Županović et al., 2008)
	Saturation level - <b>density</b>	(Županović et al., 2008)
	Traffic <b>flow</b>	Highway design manual
	Traffic <b>flow</b>	(Županović et al., 2008)
	Vehicle <b>Type</b>	Highway design manual
	Green phase duration ( <b>delay</b> )	(Pandian et al., 2009)
	Vehicle waiting time to pass the intersection- ( <b>delay</b> )	(Županović et al. 2008)
<b>9. Parking</b>	Car <b>location</b>	(Geng & Cassandras, 2012)
	Status of <b>parking</b> slots	
	Truck <b>drivers behaviors</b>	(Carrese et al., 2011)
	Vehicle <b>Type</b>	(Carrese et al., 2011)
	<b>Volume</b>	Highway design manual
	<b>Parking areas</b> (Amount, occupancy rate, users satisfaction level)	(Carrese et al., 2011)
<b>10. Policies &amp; Regulations</b>	Specific average <b>speed</b>	(Baldasano et al., 2010)
	Vehicle <b>speed</b>	(Santos et al., 2010)
	Daily average traffic ( <b>Volume</b> )	(Baldasano et al., 2010)
	Vehicle count ( <b>Volume</b> )	(Boogaard et al., 2012)
	<b>Road characteristics</b> (length, type, circulation zones)	(Baldasano et al., 2010)
	Vehicle <b>Accidents</b>	(Santos et al., 2010)
	<b>Individual vehicular data</b> (type)	(Boogaard et al., 2012)
	Vehicle <b>type</b>	(Pandian et al., 2009)
	Vehicle <b>ID</b> (age of a vehicle, and condition of its engine, vehicle maintenance)	(Pandian et al., 2009)
	Vehicle <b>Weight</b> (Capacity)	(McKinnon, 2005)
	Travel <b>Time</b>	(Turner et al., 1998)
	Travel <b>Distance</b>	(Santos et al., 2010)
	Travel <b>Trips (OD)</b>	(Santos et al., 2010)
Individuals' <b>behavior</b> (driving style and car purchasing decisions)	(Santos et al., 2010)	
<b>11. Integration stakeholders</b>	Car ownership - <b>behavior</b>	(Hull, 2005)
	Travel mode choice, route choice - <b>behavior</b>	(Fujiwara & Zhang, 2013)
	Total <b>distance</b> travelled	(Hull, 2005)
	Average daily traffic <b>flows</b>	(Hull, 2005)
	Infrastructure ( <b>Road Characteristics</b> )	(Lee et al., 2013)
	# <b>Trips</b>	(Fujiwara & Zhang, 2013)

### **APPENDIX 3. TRAFFIC DATA AND URBAN STUDIES**

Traffic studies are essential in traffic engineering, they provide the data required for project planning, project design, and traffic management. The traffic data of data to be used depends on the type of traffic analysis required. Travel time, annual traffic volumes, and traffic flows are essential components in traffic engineering studies.

- Volumes and flows are important indicators of road networks capacity.
- Driving behavior is also related to road safety analysis, microscopic traffic simulation, and intelligent transportation systems (ITS) studies.
- Accurately measuring traffic volumes and speeds is important for both research purposes and road design.
- Data on the speed and volume of traffic can be used, for instance, as a surrogate measure of safety, in level-of-service (LOS) analysis and in transportation planning studies.

Different traffic studies use traffic-flow as main input for their analysis. Traffic-flow can be grouped in two model types

- *Macroscopic models*: mathematical models based on average speed, density, and flow (Y. Wang et al., 2011).
- *Microscopic models*: mathematical models that analyze vehicle performances and interactions with road network infrastructure and surrounding vehicles. This studies incorporate driver behavior (e.g. lane changing, separation distance) of individual vehicles.

#### APPENDIX 4. TRAFFIC DATA AND POLLUTION

HGVs have their own set of EU emission standards because of their higher contribution to pollution than passenger vehicles.

European emission standards for HGVs

Tier	Date	CO	HC	NOx	PM	Smoke
Euro I	1992, < 85 kW	4.5	1.1	8.0	0.612	
	1992, > 85 kW	4.5	1.1	8.0	0.36	
Euro II	October 1996	4.0	1.1	7.0	0.25	
	October 1998	4.0	1.1	7.0	0.15	
Euro III	October 1999 (EEVs only)	1.5	0.25	2.0	0.02	0.15
	October 2000	2.1	0.66	5.0	0.10 0.13*	0.8
Euro IV	October 2005	1.5	0.46	3.5	0.02	0.5
Euro V	October 2008	1.5	0.46	2.0	0.02	0.5
Euro VI	January 2013	1.5	0.13	0.4	0.01	

Notes:

\* for engines of less than 0.75 dm<sup>3</sup> swept volume per cylinder and a rated power speed > 3000 min<sup>-1</sup>

EEV = enhanced environmentally-friendly vehicles

#### Estimation of emissions

Traffic emissions are calculated through traffic emission modelling methods. This methods based on traffic data and emission factors. The emission factors express the mass of pollutants emitted per unit distance, time, or mass of fuel burned. Emission factors vary dramatically across vehicle types. Characteristics of a vehicle (type, size, age, weight) and of its engine (condition, maintenance, standards, type) correlate to the emissions. Other traffic data used are specific average speed, AADT, VKT, road segment length, and route type.

US Environmental Protection Agency provides methodologies for estimating greenhouse gases (GHGs) based on CO<sub>2</sub>, CH<sub>4</sub>, N<sub>2</sub>O, and global warming potential (GWP). Different formulas are used to estimate GHGs for each vehicle type. Traffic emission estimates based on traffic counts are not accurate. A good analysis of speed and acceleration using traffic flow models can provide better emission estimates.

1. *Average-speed models*: emission factors are a function of the average travel speed. The speed dependency of emissions varies as a function of the pollutant, age of the vehicle, and weight and cubic capacity of the engine.
2. *Traffic-variable models*: emission factors are defined by traffic flow variables such as average speed, traffic density, queue length, and traffic signals.
3. *Cycle-variable models*: emission factors are a function of driving cycle variables (e.g. idle time, average speed, positive kinetic energy) at high precision (seconds to minutes).

## **APPENDIX 5. TRAFFIC DATA AND SAFETY**

The studies on the prediction of traffic safety can be divided into two categories:

- *Macro-level approach.* Focuses on area/location-based safety analysis, using statistical data to represent safety performance and predict the collision possibility. Traffic data used: traffic flow and geometric traffic facility characteristics.
- *Micro-level approach.* Targets individual safety using individual vehicle data. The main parameter of this model is the time to collision (TTC) value. TTC is the time that remains before two or more vehicles collide if they keep their direction and speed. The smaller a TTC value is, the more dangerous the situation.

Researchers have attempted various methods to pre-know the level of safety. For example:

- Thajchayapong et al. (2013) consider traffic anomalies<sup>1</sup> to detect possible traffic incidents. They classify traffic anomalies in transient anomalies or minor disruptions (e.g. appearance of a pedestrian on the freeway shoulder) and disruption precursors or major disruptions (e.g. accidents, crashes, or congestions).
- Son et al. (2011) explores the use of crash data and individual vehicular data (driving behavior and vehicle design characteristics) to predict the crash potential between two consecutive vehicles traveling in the same direction.

Wang et al. (2011) classify the major tasks for traffic surveillance in:

- *Traffic state estimation.* Estimating traffic flows, mean speeds, and densities for a road network, based on limited data.
- *Traffic state prediction.* Predicting traffic flow variables over a future time horizon.
- *Travel time prediction.* Predicting the travel time experienced along any route at certain time instant.
- *Incident alarm.* Notifying real-time incidents (e.g., traffic accidents and network faults).

---

<sup>1</sup> Traffic anomalies: the deviations from the normal traffic patterns e.g. road surface state (slippery road conditions) and traffic incidents (road construction, protest rally).

**APPENDIX 6. ICT BARRIERS OF ADOPTION AND EXAMPLES**

Adoption barriers for ICT are divided in three categories according to their area of impact:

1. *User-related barriers*: Relate to the company’s environment. Some of the factors include: size of the company, economy and finances, operations, reluctance to change, and management.
2. *Technology-related barriers*: Relate to the technological constraints that prevent full utilization of ICT applications. Some of the factors include: interoperability of systems, ICT integration, standardization, security and data protection, rapid obsolescence of technology.
3. *Policy-related barriers*: Relate to the coordination and harmonization of different policy levels. The main factor is the unwillingness of stakeholders to cooperate with each other.

Impact of technological trends on barriers to ICT adoption (Harris et al., 2015)

<b>Enabling tech.</b> <b>ICT Barriers</b>	<b>Cloud computing</b>	<b>Social Networking</b>	<b>Wireless/ Mobile communication tech. and IoT</b>	<b>Advances in interface technologies</b>
<b>User-related</b>	ooo	ooo	ooo	ooo
<b>Technology-Related</b>	ooo	oo	ooo	oo
<b>policy-Related</b>	oo	o	oo	o

Key: ooo = Strong impact, oo = Medium impact, o = Weak impact, n/a = technology not currently deployed.



ICT traffic data collection methods

ICT	Project description	Reference
Advanced Traveler Information Systems ( <b>ATIS</b> ), Advanced Traffic Management Systems ( <b>ATMS</b> ), Advanced Vehicle Control Systems ( <b>AVCS</b> ), Commercial Vehicle Operation ( <b>CVO</b> )	In-vehicle navigation system which uses advanced ICT to manage traffic, advise drivers, and control vehicle flow. (e.g. small vehicles for city deliveries, special transshipment technology: Abroll Container Transport System in Switzerland, Metrocargo in Italy - Cargo Domino project in Zurich)	(Russo & Comi, 2010)
<b>Smart phone application:</b> a) Minimum time to destination b) Economy in fuel to arrive at destination	Offer maximum of 6 routes for a specific travel. The type and number of hurdles for specific routes will determine the time and give commuter options in making a decision to take a particular route.	(Syed et al., 2014)
<b>Smart phone application:</b> Virtual trip lines (VTL)	Each VTL consists of two GPS coordinates which make a virtual line drawn across a roadway of interest. Markers stored in the mobile phone trigger position and speed updates when the mobile phone crosses them.	(Herrera et al., 2010)
Vehicular network technology and dedicated short range communication ( <b>DSRC</b> ).	Enhance the visibility and connectivity in the multimodal logistics environment through	(Harris et. al., 2015)
<b>Smart Parking System</b> Infrastructure	The Parking Resource Management Center (PRMC) collects and updates all real-time parking information. The Driver Request Processing Center gathers driver parking requests and real-time information. The Smart Parking Allocation Center makes assignment decisions and allocates and reserves parking spots for drivers.	(Geng & Cassandras, 2012)
<b>Integrator Class 2 Sound Level Meter</b> (Microphone)	On-road traffic noise data collection system	(Pirrera et al., 2014)
<b>Fastrak or EZ-Pass</b> - California U.S.A.	Radio-frequency identification (RFID) transponders	(Herrera et al., 2010)
<b>PEEK's ADR-3000</b>	Automatic traffic counters connected to ILD stations	(Son et al., 2011)
Transit signal priority ( <b>TSP</b> )	Extend the green phase of traffic signals to claim the right-of-way and proceed unimpeded through an intersection. Loses effectiveness with heavy traffic.	(Eichler & Daganzo, 2006)
<b>HICOMP</b> - (U.S.A)	GPS devices in dedicated probe vehicles to monitor traffic for some freeways and major highways in California	(Herrera et al., 2010)
<b>DRIVEIN2</b> (DRIVER monitoring: technologies, methodologies, and IN-vehicle INnovative systems)	The project relies on driving data collected by means of both an instrumented vehicle (IV) used for naturalistic (on-the-road) observations and a driving simulator (DS).	(Bifulco et al., 2014).
<b>PTFM</b> - U.K.	TrafficMaster's passive target flow management on trunk roads via License Plate Recognition (LPR)	(Herrera et al., 2010)
<b>DOT's</b> - Oregon U.S.A	LPR Frontier Travel Time project	(Santos et al., 2010)

## APPENDIX 7. ONLINE QUESTIONNAIRE

### Questionnaire to Evaluate Freight Traffic Data

Description:

The Municipality of Eindhoven wants to perform a situational analysis of the traffic behavior of the city of Eindhoven for better policy making. In order to do this, the first step is to identify the most important freight traffic data in the city.

This questionnaire targets to rate, among the different stakeholders of freight transport, the most significant freight traffic criteria in The Netherlands. The goal is to identify the most important traffic data that should be analyzed by authorities. This questionnaire is part of a Thesis research of the Eindhoven University of Technology (TU/e) for the Master of Construction Management & Engineering.

Freight traffic: traffic generated by vehicles for the process of transporting goods and cargo.

This questionnaire will take you approximately 5 min.

Start

1. **What is the name of your organization?\***

2. **Which sector suits you best?\***

- Authority
- Mobility Expert - Researcher
- Freight Company
- Citizen
- Retailer - Shopping Center Manager

3. **Which is your current position?\***

- CEO
- Director
- Project Manager
- Manager
- Professor
- Advisor
- Student (PhD, MSc)
- Other

## Appendices

### Instructions:

You will be asked to compare different concepts according to their importance.

Please select the option that best describe your opinion about the degree of importance of one element respect to the other.

Please NOTICE:

- The CLOSEST circle to the CONCEPT = the concept is EXTREMELY more important than the other.

- In between circles are:

VERY LARGELY more important

LARGELY more important

MODERATELY more important

- The MIDDLE circle = concepts are EQUALLY important.

4.

### Step 1. Rate the following criteria.

- **REDUCE NEGATIVE IMPACTS:** congestion, pollution, safety risks.
- **IMPROVE EFFICIENCY USING ICT/ITS (Technologies):** Optimal route & Logistics.
- **OPTIMIZE INFRASTRUCTURE:** roads, intersections, parking spaces.
- **ENHANCE POLICY-MAKING:** Reinforce regulations, policies, and integration of different stakeholders.

Which of the 2 elements you consider more important for **FREIGHT TRAFFIC DATA COLLECTION?**

Reduce negative impacts	● ● ● ● ● ● ● ● ● ●	Improve efficiency of ICT/ITS
Reduce negative impacts	● ● ● ● ● ● ● ● ● ●	Optimize infrastructure
Improve efficiency of ICT/ITS	● ● ● ● ● ● ● ● ● ●	Optimize infrastructure
Reduce negative impacts	● ● ● ● ● ● ● ● ● ●	Enhance policy-making
Improve efficiency of ICT/ITS	● ● ● ● ● ● ● ● ● ●	Enhance policy-making
Optimize infrastructure	● ● ● ● ● ● ● ● ● ●	Enhance policy-making

5.

### Step 2. Rate the following sub-criteria:

- **CONGESTION:** Slower speeds, longer trip times, and increased vehicular queuing on road networks.
- **POLLUTION:** Contaminants into the natural environment.
- **SAFETY:** Risk of being injured or dead.

Which of the 2 elements you consider more important for **REDUCING NEGATIVE IMPACTS?**

Congestion	● ● ● ● ● ● ● ● ● ●	Pollution
Congestion	● ● ● ● ● ● ● ● ● ●	Safety
Pollution	● ● ● ● ● ● ● ● ● ●	Safety
Noise Pollution	● ● ● ● ● ● ● ● ● ●	Air Pollution

## Appendices

6.

**Step 3. Rate the following sub-criteria:**

- **OPTIMAL ROUTE:** Time and fuel reduction (smart parking, new navigation systems, etc.).
- **LOGISTICS IMPROVEMENT:** Better logistics from delivery companies (real-time information and efficient data exchange).

**Which of the 2 elements you consider more important for IMPROVING DELIVERY LOGISTICS?**

Optimal route            Logistics improvement

7.

**Step 4. Rate the following sub-criteria:**

- **ROADS:** maintenance and expansions.
- **INTERSECTIONS:** e.g. traffic lights, signalization, etc.
- **PARKING SPACES:** Increase and improve.

**Which of the 2 elements you consider more important for OPTIMIZING INFRASTRUCTURE?**

Roads            Intersections  
Roads            Parking spaces  
Intersections            Parking spaces

8.

**Final Step. Rate the following sub-criteria:**

- **REGULATIONS:** limit speed, special lanes, euro standards for the engine emissions, delivery frequency, loading time restrictions, etc.
- **INTEGRATION OF DIFFERENT STAKEHOLDERS:** Integration across different sectors (public & private), different government institutions, etc.

**Which of the 2 elements you consider more important for ENHANCING POLICY-MAKING?**

Regulations            Integration of different stakeholders

9.

**In case of a single inconsistent answer that prevents the entire questionnaire to be used as input for the research method, we would like to contact you back for re-considering the value of that answer.**

**What is your e-mail?**

10.

**Comments:**

Submit survey

**APPENDIX 8. RECONDISER ANSWER FORMAT**

Dear respondent,

Hope you are doing great! This e-mail is because only 1 of your answers is making inconsistent the questionnaire that you kindly answered. Therefore it cannot be used in the research method analysis. In order to have a consistent questionnaire I would like to ask you to reconsider your answer in the following question:

Your selection:

7. **Step 4. Rate the following sub-criteria:**

- **ROADS: maintenance and expansions.**
- **INTERSECTIONS: e.g. traffic lights, signalization, etc.**
- **PARKING SPACES: Increase and improve.**

**Which of the 2 elements you consider more important for OPTIMIZING INFRASTRUCTURE?**

Roads	<input type="radio"/>	<input type="radio"/>	<input type="radio"/>	<input type="radio"/>	<input type="radio"/>	<input type="radio"/>	<input checked="" type="radio"/>	<input type="radio"/>	<input type="radio"/>	Intersections
Roads	<input type="radio"/>	<input type="radio"/>	<input checked="" type="radio"/>	<input type="radio"/>	<input type="radio"/>	<input type="radio"/>	<input type="radio"/>	<input type="radio"/>	<input type="radio"/>	Parking spaces
Intersections	<input type="radio"/>	<input type="radio"/>	<input checked="" type="radio"/>	<input type="radio"/>	<input type="radio"/>	<input type="radio"/>	<input type="radio"/>	<input type="radio"/>	<input type="radio"/>	Parking spaces

The following options maintain your selection of the more important value of the pairwise comparison and only vary in the degree of importance. Are you willing to reconsider your selection to one of the following options? If yes, please select one option.

a)	Roads	<input type="radio"/>	<input type="radio"/>	<input type="radio"/>	<input type="radio"/>	<input type="radio"/>	<input checked="" type="radio"/>	<input type="radio"/>	<input type="radio"/>	Intersections
	Roads	<input type="radio"/>	<input type="radio"/>	<input checked="" type="radio"/>	<input type="radio"/>	<input type="radio"/>	<input type="radio"/>	<input type="radio"/>	<input type="radio"/>	Parking spaces
	Intersections	<input type="radio"/>	<input type="radio"/>	<input checked="" type="radio"/>	<input type="radio"/>	<input type="radio"/>	<input type="radio"/>	<input type="radio"/>	<input type="radio"/>	Parking spaces
b)	Roads	<input type="radio"/>	<input type="radio"/>	<input type="radio"/>	<input type="radio"/>	<input type="radio"/>	<input checked="" type="radio"/>	<input type="radio"/>	<input type="radio"/>	Intersections
	Roads	<input type="radio"/>	<input type="radio"/>	<input checked="" type="radio"/>	<input type="radio"/>	<input type="radio"/>	<input type="radio"/>	<input type="radio"/>	<input type="radio"/>	Parking spaces
	Intersections	<input checked="" type="radio"/>	<input type="radio"/>	<input type="radio"/>	<input type="radio"/>	<input type="radio"/>	<input type="radio"/>	<input type="radio"/>	<input type="radio"/>	Parking spaces
c)	Roads	<input type="radio"/>	<input type="radio"/>	<input type="radio"/>	<input type="radio"/>	<input type="radio"/>	<input checked="" type="radio"/>	<input type="radio"/>	<input type="radio"/>	Intersections
	Roads	<input type="radio"/>	<input checked="" type="radio"/>	<input type="radio"/>	<input type="radio"/>	<input type="radio"/>	<input type="radio"/>	<input type="radio"/>	<input type="radio"/>	Parking spaces
	Intersections	<input checked="" type="radio"/>	<input type="radio"/>	<input type="radio"/>	<input type="radio"/>	<input type="radio"/>	<input type="radio"/>	<input type="radio"/>	<input type="radio"/>	Parking spaces

Answer = \_\_\_\_\_

**APPENDIX 9. CORRELATIONS FOR PHASE I OF QFD.**

Correlation assumptions and references HOWs

Correlated data	Reference		Reason
Distance VKT - # journeys	(Browne et al., 2012)	++	OD
Distance VKT - Volume	(Leduc, 2008)	+	Indicator
Distance VKT - Density	-		Could be an indicator but distance is already affecting volume and volume affects density
Distance VKT - Travel time	-	++	Formula $D = V * T$
Distance VKT - Travel speed	-	++	Formula $D = V * T$
Distance VKT - Behavior	-		route choice is already affecting OD
Distance + Vehicle Id. (engine)	-	++	Fuel consumption
OD - Volume	(Wismans et al., 2014)	++	Need to be counted
OD - Direction	-	+	Trajectory can estimate Destination but is a + because also Location can provide this
OD - Location	-	+	Initial and End location = OD, same as direction
OD - Time	-		OD cannot be estimated with time
OD - Driver Behavior	-	++	Motives for traveling = OD
OD - Weight	-	+	Freight vehicle Destination change if with cargo or empty
OD - Type	-		vehicle type is already affecting behavior and behavior OD
Volume - Direction	-	+	Each lane flow or direction gives a different volume
Volume - density	(Gentili & Mirchandani, 2012)	++	Formula $p = Vol./Length$
Volume - flow	(Gentili & Mirchandani, 2012)	++	Formula $Q = Vol./hr.$
Volume - Queue length	-	+	With a factor of Vehicle length, volume can be estimated
Volume - Noise level	(Zhenshan et al., 2010)	++	Vehicles can be id. Via sound
Volume - behavior	(Gentili & Mirchandani, 2012)	+	Lane occupancy detection and count
Volume - type	-	+	Each vehicle class can give a different volume
Direction - Location	-	++	Two location data = direction (OD)
Direction - Density	(Bauza & Gozalvez, 2013)	+	Formula $p = Vol./Length$ (Road Length relates with direction)
Direction - Flow	-	+	Flow $Q = Vol./hr.$ in an checkpoint (normally indicator of direction)
Direct - Driving Behavior	-	++	Turn choice, lane occupancy
Location - Time	(Turner et al., 1998)	++	Average speed can predict time to reach Location 2 + Time stamp on locations
Location - speed	(Bauza & Gozalvez, 2013)	++	Travel time for reaching Location1 & 2 = speed
Location - Accidents	-	+	Extra parameter, knowledge of the accident location
Location - Behavior	(Syed et al., 2014)	+	Lane Change + distance headway or rear

## Appendices

Location - ID	-	++	ID tags normally also give vehicle's position
Location - Road Type	-	++	Know location = know which type of road in the network
Density - Delay	-		Slow movement = delay but is affecting speed already (speed is correlated with time and time with delay)
Density - Queue length	-	++	Formula $p = \text{Vol.}/\text{Length}$
Density - speed	(Bauza & Gozavez, 2013)	++	Critical density = slow movement = affect time
Density - speed	(Turner et al., 1998)		
Density - accident	(Marchesini & Weijermars, 2010)	+	Crowded increases risk accident (vehicle contact) (V/C Ratio)
Density - Behavior	-	+	Increase stress, modify behavior
Density - Vehicle Type	-		Volume changes depending on lengths but is already related to queue
Flow - Noise level	(Kumar et al., 2014)	++	highway traffic noise modeling input parameters are vehicle volume/hour, percentage of heavy vehicles and average vehicle speed and
Flow - Speed	-	++	Speed will affect the volume of vehicles in the flow
Travel delay - Travel time	(Quiroga, 2000)	++	Time related
Queue length - Speed	-	++	Obstacle for flow
Queue length - Behavior	-		Increase stress, modify behavior but already affected in density
Queue length - Vehicle Type	-	++	Length changes depending on lengths
Time NOT affect Journey	-		Because Journey is affected by speed regarding limits and speed already affects Journey
Travel time - Travel speed	(Quiroga, 2000)	++	Travel time can also be estimated in certain cases by assuming the average speed at a particular point (spot speed) is constant for a relatively short distance (typically
	(Kwong et al., 2009)		
	(Turner et al., 1998)		
Time - average speed	(Turner et al., 1998)	++	Formula
Travel time - accidents	(Turner et al., 1998)		Is affecting Speed (raw data)
Noise level - Speed	(Kumar et al., 2014)	++	highway traffic noise modeling input parameters are vehicle volume/hour, percentage of heavy vehicles and average vehicle speed and
Noise level - Behavior	-	++	Stress = Claxons
Noise level - Type	(Kumar et al., 2014)	++	highway traffic noise modeling input parameters are vehicle volume/hour, percentage of heavy vehicles and average vehicle speed and
Speed - Behavior	-	++	Individual's different speed preferences, and if follow limits or not
Speed - Truck weight	(McKinnon, 2005)	+	More weight less speed
Speed - Vehicle type	-	++	Vehicle type is different speeds average
Speed - Vehicle ID	-	++	Vehicle's engine (Ferrari vs combi)
Speed - Road Type	-	++	Speed limits and type of pavement
Accidents - behavior	-	++	Precaution
Behavior - Type	-	++	Route Choice type of transport
Behavior - Id	-	++	Id. Vehicle driver, profile behavior
Vehicle weight - type	-	++	Standardized weights per type (no cargo)
Vehicle weight - id	-	++	Vehicle Id. Estimate containing cargo and weight
Vehicle type - id	-	++	If vehicle is Id. Type is also known

Correlation assumptions and references WHATs

Correlated criteria	Reference		Reason
Congestion - Air Pollution	(Marchesini & Weijermars, 2010)	++	Directly proportional, more volume and idle time more pollution
Congestion - Noise pollution	-		Driving behavior is already affecting noise pollution.
Congestion - Safety	(Marchesini & Weijermars, 2010)	+	Traffic congestion has a negative impact on the economy and on the quality of people's lives. Road users experience delay and stress, and environmental pollution increases. The effects of traffic congestion on traffic safety, however, are less obvious
Congestion - Optimal route	-	++	Optimal route needs the congestion status as parameter
Congestion - Logistics	-	++	Logistics need the congestion status as parameter
Congestion - Roads, Intersect	-		The specific data (flow, volume) are already taken into account
Congestion - Parking	-	++	The better infra. And logistics to park, diminish general congestion
Congestion - Regulations	-	+	Regulations aim to reduce negative effects as congestion, pollution etc.
Congestion - Integration	-	+	Integration is related to all aspects due its common interest
Noise pollution - Regulations	-	+	Noise pollution analysis, and maximum speed regulations
Noise pollution - Integration	-	+	Integration is related to all aspects due its common interest
Safety - Roads	Highway Design Manual	++	Infrastructure targets users' safety
Safety - Parking	(Carrese et al., 2011)	++	Safety level HGVs
Safety - Intersection	Highway Design Manual	++	Timing of traffic signals, considering to accommodate pedestrian crossing
Optimal Route - Logistics	-	++	Same objectives for both criteria
Optimal Route - Roads	(McKinnon, 2005)	+	Reduce road pavement damage per kilometer travelled, McKinnon
Optimal Route - Intersections	-	+	Conflict points improved - directly relation with better route and logistics
Logistics - Roads	(McKinnon, 2005)	+	Reduce road pavement damage per kilometer travelled, McKinnon
Logistics - Intersections	-	+	Conflict points improved - directly relation with better route and logistics
Logistics - Regulations	(McKinnon, 2005)	++	Optimizing weight of freight vehicles (logistics) optimizes consolidation. Also reducing taxes for vehicle (VED)
Regulations – Stake. Integra.	-	++	Important to put interests together when creating regulations



**APPENDIX 10. TRAFFIC DATA COLLECTION TECHNIQUES AND TRAFFIC DATA**

In-situ and on-board techniques collected data – literature review

<b>Data collection method</b>	<b>Type of Traffic Data collected</b>	<b>Reference</b>
Pneumatic road tubes	Number of vehicles - <b>volume</b>	(Leduc 2008)
Pneumatic road tubes	Traffic <b>volume</b>	(Lopes et al., 2010)
Pneumatic road tubes	<b>Volume</b>	(Hamra & Attallah, 2011)
Pneumatic road tubes	<b>Volume counts</b>	(Gentili & Mirchandani, 2012)
Pneumatic road tubes	<b>Speed</b>	(Leduc, 2008)
Pneumatic road tubes	<b>Speed</b>	(Lopes et al., 2010)
Pneumatic road tubes	<b>Speed</b>	(Hamra & Attallah, 2011)
Pneumatic road tubes	<b>Vehicle type/classification</b>	(Leduc, 2008)
Pneumatic road tubes	<b>Vehicle type/classification</b>	(Lopes et al., 2010)
Pneumatic road tubes	<b>Vehicle type/classification</b>	(Hamra & Attallah, 2011)
Pneumatic road tubes	<b>Density</b>	(Lopes et al., 2010)
Piezoelectric sensors	Number of vehicles - <b>volume</b>	(Lopes et al., 2010)
Piezoelectric sensors	Number of vehicles - <b>volume</b>	(Leduc, 2008)
Piezoelectric pads	<b>Volume counts</b>	(Gentili & Mirchandani, 2012)
Piezoelectric sensors	<b>Speed</b>	(Lopes et al., 2010)
Piezoelectric sensors	<b>Vehicle Speed</b>	(Leduc, 2008)
Piezoelectric sensors	<b>Speed</b>	(Hamra & Attallah, 2011)
Piezoelectric sensors	Occupancy - <b>Direction</b>	(Leduc, 2008)
Piezoelectric sensors	<b>Density</b>	(Lopes et al., 2010)
Piezoelectric sensors	Vehicle ( <b>type &amp; weight</b> )	(Hamra & Attallah, 2011)
Piezoelectric sensors	Vehicle ( <b>type &amp; weight</b> )	(Lopes et al., 2010)
ILD	Number of vehicles - <b>volume</b>	(Leduc, 2008)
ILD	Number of vehicles - <b>volume</b>	(Son et al., 2011)
ILD	Number of vehicles - <b>volume</b>	(Wang et al., 2011)
ILD	Truck event data (truck <b>volumes</b> )	(Liu et al., 2014)
ILD	Number of vehicles - <b>volume</b>	(Wismans et al., 2014)
ILD	<b>Volume</b> counts	(Gentili & Mirchandani, 2012)
ILD	<b>Volume</b>	(Lopes et al., 2010)
ILD	<b>Speed</b>	(Leduc, 2008)
ILD	<b>Speed</b>	(Wang et al., 2011)
ILD	<b>Speed</b>	(Lopes et al., 2010)
ILD	Traffic flow - <b>Speed</b>	(Thajchayapong et al., 2013)
ILD	Traffic flow - <b>Speed</b>	(Gongjun et al., 2012)
ILD	Traffic flow - <b>Speed</b>	(Vaqr & Basir, 2009)
ILD	Average truck <b>speeds</b>	(Liu et al., 2014)
ILD	Vehicle <b>Speed</b>	(Bifulco et al., 2014)
ILD	<b>Queue length</b>	(Gajda et al., 2012)
ILD	<b>Vehicle type/classification</b>	(Leduc, 2008)
ILD	<b>Vehicle type/classification</b>	(Liu et al., 2014)
ILD	<b>Vehicle type/classification</b>	(Lopes et al., 2010)
ILD	<b>Vehicle</b> (length)	(Bifulco et al., 2014)
ILD	Truck <b>weights &amp; lengths</b>	(Liu et al., 2014)

Appendices

ILD	Lane Occupancy - <b>Location</b>	(Thajchayapong et al., 2013)
ILD	Lane Occupancy - <b>Direction</b>	(Leduc, 2008)
ILD	Lane Occupancy - <b>Direction</b>	(Thajchayapong et al., 2013)
ILD	<b>Time</b>	(Bifulco et al., 2014)
ILD	<b>Flow</b>	(Thajchayapong et al., 2013)
ILD	Traffic <b>density</b>	(Ding et al., 2012)
ILD	<b>Densities</b>	(Wang et al., 2011)
ILD	<b>Density</b>	(Lopes et al., 2010)
ILD	Traffic flow - <b>density</b>	(Gongjun et al., 2012)
ILD	Traffic flow - <b>density</b>	(Vaqr & Basir, 2009)
ILD	<b>Driving behavior</b> - lane-changing counts	(Thajchayapong et al., 2013)
Video Cameras	Crash data - <b>Incident</b>	(Son et al., 2011)
Video Cameras	<b>Incident</b> detection	(Leduc, 2008)
Video Cameras	<b>Accidents</b>	(Tai et al., 2004)
Video Cameras	<b>Incident</b> detection	(Gongjun et al., 2012)
Video Cameras	Number of vehicles - <b>volume</b>	(Wang et al., 2011)
Video Cameras	Number of vehicles - <b>volume</b>	(Leduc, 2008)
Video Cameras	Number of vehicles - <b>volume</b>	(Berkowicz et al., 2006)
Video Cameras	Number of vehicles - <b>volume</b>	(Wismans et al., 2014)
Video Cameras	Traffic <b>Volume</b>	(Kassomenos et al., 2006)
Video Cameras	<b>Volume</b> counts	(Gentili & Mirchandani, 2012)
Video Cameras	<b>Volume</b> counts	(Hamra & Attallah, 2011)
Video Cameras	<b>Volume</b> counts	(Tai et al., 2004)
Video Cameras	Traffic <b>Volume</b>	(Lopes et al., 2010)
Video Cameras	<b>Speed</b>	(Wang et al., 2011)
Video Cameras	<b>Speed</b>	(Leduc, 2008)
Video Cameras	<b>Speed</b>	(Kassomenos et al., 2006)
Video Cameras	<b>Speed</b>	(Lopes et al., 2010)
Video Cameras	Traffic flow data - <b>Speed</b>	(Vaqr & Basir, 2009)
Video Cameras	Traffic flow data - <b>Speed</b>	(Gongjun et al., 2012)
Video Cameras	Traffic flow data - <b>Speed</b>	(Ding et al., 2012)
Video Cameras	<b>Speed</b>	(Hamra & Attallah, 2011)
Video Cameras	<b>Speed</b>	(Tai et al., 2004)
Video Cameras	<b>Speed</b>	(Gribbon, 1998)
Video Cameras	<b>Flow</b>	(Tai et al., 2004)
Video Cameras	<b>Density</b>	(Wang et al., 2011)
Video Cameras	<b>Density</b>	(Lopes et al., 2010)
Video Cameras	Occupancy - <b>Density</b>	(Leduc, 2008)
Video Cameras	Traffic flow data - <b>Density</b>	(Vaqr & Basir, 2009)
Video Cameras	Traffic flow data - <b>Density</b>	(Gongjun et al., 2012)
Video Cameras	Traffic flow data - <b>Density</b>	(Ding et al., 2012)
Video Cameras	<b>Vehicle Characteristics</b>	(Thajchayapong et al., 2013)
Video Cameras	<b>Vehicle type</b> /classification	(Leduc, 2008)
Video Cameras	<b>Vehicle type</b> /classification	(Kassomenos et al., 2006)
Video Cameras	<b>Vehicle type</b> /classification	(Lopes et al., 2010)
Video Cameras	<b>Vehicle type</b> /classification	(Hamra & Attallah, 2011)

## Appendices

Video Cameras	<b>Vehicle characteristics</b>	(Ding et al., 2012)
Video Cameras	<b>O-D</b>	(Lopes et al., 2010)
Video Cameras	<b>O-D</b>	(Leduc, 2008)
Video Cameras	<b>Direction</b>	(Bifulco et al., 2014)
Video Cameras	<b>Travel time</b>	(Turner et al., 1998)
Video cameras	Pedestrian behavior - <b>Road Characteristics</b>	(Zhang et al., 2012)
Magnetic (Passive)	<b>Speed</b>	(Gibbon, 1998)
Magnetic (Passive)	<b>Speed</b>	(Hamra & Attallah, 2011)
Magnetic (Passive)	<b>Volume counts</b>	(Hamra & Attallah, 2011)
Magnetic detectors	<b>Volume counts</b>	(Gentili & Mirchandani, 2012)
Magnetic detectors	<b>Occupancy - Direction</b>	(Weil et al., 1998)
Magnetic (Passive)	<b>Type</b>	(Hamra & Attallah, 2011)
Manual counts	Number of vehicles - <b>volume</b>	(Leduc, 2008)
Manual counts	Traffic <b>volume</b>	(Kassomenos et al., 2006)
Manual counts	<b>Road Characteristics</b> (pedestrians)	(Leduc, 2008)
Manual counts	<b>Vehicle Characteristics</b> (type/classification)	(Leduc, 2008)
Manual counts	Vehicle <b>classification</b>	(Hamra & Attallah, 2011)
Manual counts	<b>Vehicle Characteristics</b> (type/classification)	(Kassomenos et al., 2006)
Manual counts	Occupancy - <b>Direction</b>	(Leduc, 2008)
Manual counts	<b>Density</b>	(Hamra & Attallah, 2011)
Manual counts	<b>Time</b>	(Berkowicz et al., 2006)
Manual counts	<b>Speed</b>	(Kassomenos et al., 2006)
Moving observer	<b>Travel time</b>	(Taylor et al., 2000)
Moving observer	<b>Volume</b>	(Taylor et al., 2000)
Moving observer	Intersections movement counts - <b>Behavior</b>	(Taylor et al., 2000)
Moving observer	<b>Accidents - Road crash data</b>	(Taylor et al., 2000)
Moving observer	<b>Speed</b>	(Taylor et al., 2000)
Moving observer	<b>Delay.</b>	(Taylor et al., 2000)
Aerial surveys	<b>Travel times</b>	(Lopes et al., 2010)
Aerial surveys	Origin-Destination ( <b>O-D</b> )	(Lopes et al., 2010)
Aerial + Cameras	Flow	(Gentili & Mirchandani, 2012)
Aerial surveys	Vehicle <b>density</b>	(Turner et al., 1998)
Aerial surveys	Track vehicle movement - <b>location</b>	(Turner et al., 1998)
Infrared	<b>Speed</b>	(Leduc, 2008)
Infrared	<b>Speed</b>	(Lopes et al., 2010)
Infrared (passive)	<b>Speed</b>	(Gibbon, 1998)
Infrared (passive & active)	<b>Speed</b>	(Hamra & Attallah, 2011)
Infrared	Number of vehicles - <b>volume</b>	(Leduc, 2008)
Infrared	Traffic <b>Volume</b>	(Lopes et al., 2010)
Infrared	Lane-occupancy ( <b>Direction</b> )	(Leduc, 2008)
Infrared (passive)	<b>Volume counts</b>	(Hamra & Attallah, 2011)

## Appendices

Infrared	<b>Density</b>	(Lopes et al. 2010)
Infrared	<b>Vehicle type</b>	(Leduc 2008)
Infrared	<b>Vehicle characteristics</b>	(Thajchayapong et al., 2013)
Infrared (passive & active)	<b>Vehicle type</b>	(Thajchayapong et al., 2013)
Infrared	<b>Vehicle type</b>	(Lopes et al., 2010)
Microwave Radar	<b>Speed</b>	(Lopes et al., 2010)
Microwave radar	<b>Speed</b>	(Leduc, 2008)
Microwave radar	<b>Speed</b>	(Gongjun et al., 2012)
Doppler & Radar	<b>Speed</b>	(Gibbon, 1998)
Microwave Doppler	<b>Speed</b>	(Hamra & Attallah, 2011)
Microwave	<b>Direction</b>	(Jamal et al., 2015)
Microwave	<b>Direction</b>	(Wang, 1992)
Microwave radar	Occupancy - <b>Direction</b>	(Leduc, 2008)
Microwave	<b>Queue length</b>	(Wang, 1992)
Microwave radar	Traffic <b>Volume</b>	(Lopes et al., 2010)
Microwave radar	Number of vehicles - <b>volume</b>	(Leduc, 2008)
Microwave Doppler	<b>Volume counts</b>	(Hamra & Attallah, 2011)
Microwave radar	<b>Density</b>	(Lopes et al., 2010)
Microwave radar	<b>Density</b>	(Gongjun et al., 2012)
Microwave radar	Vehicle <b>type</b>	(Lopes et al., 2010)
Microwave Doppler	Vehicle <b>type</b>	(Hamra & Attallah, 2011)
Microwave radar	Vehicle <b>type</b>	(Leduc, 2008)
Microwave radar	<b>Incident</b> detection	(Leduc, 2008)
Microwave radar	<b>Incident</b> detection	(Gongjun et al., 2012)
Laser sensors	<b>Speed</b>	(Harlow & Peng, 2001)
Laser sensors	Vehicle <b>type</b>	(Harlow & Peng, 2001)
Laser sensors	<b>Volume</b>	(Weil et al., 1998)
Laser sensors	Occupancy - <b>Direction</b>	(Weil et al., 1998)
Laser sensors	<b>Density</b>	(Weil et al., 1998)
Pulse ultrasonic	<b>Speed</b>	(Gibbon, 1998)
Pulse ultrasonic	<b>Speed</b>	(Hamra & Attallah, 2011)
Pulse ultrasonic	<b>Volume counts</b>	(Hamra & Attallah, 2011)
Pulse ultrasonic	Vehicle <b>classification</b>	(Hamra & Attallah, 2011)
Acoustic tracking syst.	<b>Speed</b>	(Lopes et al., 2010)
Acoustic tracking syst.	<b>Speed</b>	(Leduc, 2008)
Acoustic tracking syst.	<b>Speed</b>	(Gongjun et al., 2012)
Passive Acoustic	<b>Speed</b>	(Hamra & Attallah, 2011)
Passive Acoustic	<b>Speed</b>	(Gibbon, 1998)
Passive Acoustic	Occupancy - <b>Direction</b>	(Leduc, 2008)
Acoustic tracking syst.	Traffic <b>Volume</b>	(Lopes et al., 2010)
Acoustic tracking syst.	Number of vehicles - <b>volume</b>	(Leduc, 2008)
Passive Acoustic	<b>Volume counts</b>	(Hamra & Attallah, 2011)
Acoustic tracking syst.	Detection of vehicles - <b>volume</b>	(Zhenshan et al., 2010)
Acoustic tracking syst.	<b>Density</b>	(Lopes et al., 2010)
Acoustic tracking syst.	<b>Density</b>	(Ding et al., 2012)

## Appendices

Acoustic tracking syst.	<b>Density</b>	(Gongjun et al., 2012)
Acoustic tracking syst.	Vehicle <b>classification</b>	(Lopes et al., 2010)
Passive Acoustic	Vehicle <b>classification</b>	(Hamra & Attallah, 2011)
Acoustic tracking syst.	Vehicle <b>classification</b>	(Leduc, 2008)
Acoustic tracking syst.	<b>Noise levels</b>	(Pirrera et al., 2014)
Acoustic tracking syst.	<b>Incident</b> detection	(Gongjun et al., 2012)
Probe vehicles - GPS	<b>Position</b>	(Sanwal & Walrand, 1995)
Probe vehicles - GPS	Real-time state of <b>position</b>	(Zhu et al., 2013)
Probe vehicles - GPS	Vehicle <b>location</b>	(Turner et al., 1998)
Probe vehicles - GPS	Vehicle <b>location</b>	(Taylor et al., 2000)
Probe vehicles - GPS	Vehicle <b>location</b>	(Leduc, 2008)
Probe vehicles - GPS	Instantaneous velocity readings - <b>speed</b>	(Herrera et al., 2010)
Probe vehicles - GPS	Real-time state of <b>speed</b>	(Zhu et al., 2013)
Probe vehicles - GPS	<b>Speed &amp; acceleration</b>	(Taylor et al., 2000)
Probe vehicles - GPS	<b>Speed</b>	(Leduc, 2008)
Probe vehicles - GPS	<b>Speed</b>	(Sanwal & Walrand, 1995)
Probe vehicles - GPS	Vehicle <b>speed</b>	(Syed et al., 2014)
Probe vehicles - GPS	Vehicle <b>Direction</b>	(Zhu et al., 2013)
Probe vehicles - GPS	<b>Road Characteristics</b> (Traffic light sensing)	(Zhu et al., 2013)
Probe vehicles - GPS	Real-time	(Zhu et al., 2013)
Probe vehicles - GPS	<b>Time</b> -tagged info	(Taylor et al., 2000)
Probe vehicles - GPS	Travel <b>times</b>	(Lopes et al., 2010)
Probe vehicles - GPS	<b>Travel time</b>	(Turner et al., 1998)
Probe vehicles - GPS	<b>Distance</b>	(Taylor et al., 2000)
Probe vehicles - GPS	<b>Vehicle Id.</b> (Engine characteristics)	(Taylor et al., 2000)
Probe vehicles - GPS	<b>OD Flows</b>	(Lopes et al., 2010)
Probe vehicles - GPS	Trajectories ( <b>Direction - OD</b> )	(Bifulco et al., 2014)
Probe vehicles - GPS	Sub path <b>flows</b>	(Lopes et al., 2010)
Probe vehicles - GPS	<b>Incident</b> detection	(Leduc, 2008)
Probe vehicles - GPS	<b>Queue</b> detection	(Leduc, 2008)
Probe vehicles - GPS	<b>Vehicle type</b>	(Leduc, 2008)
Probe vehicles - GPS	<b>Position speed and direction</b>	(Vaqaar & Basir, 2009)
Probe vehicles - GPS	<b>Driving behavior</b>	(Turner et al., 1998)
Probe vehicles - RFID	<b>Position</b>	(Sanwal & Walrand, 1995)
Probe vehicles - RFID	<b>Location and O-D</b>	(Hamra & Attallah, 2011)
Probe vehicles - RFID	<b>Times</b>	(Gentili & Mirchandani, 2012)
Probe vehicles - RFID	<b>Vehicle ID</b> (LPR)	(Gentili & Mirchandani, 2012)
Probe vehicles - RFID	Number of vehicles - <b>volume</b>	(Wang et al., 2011)
Probe vehicles - RFID	<b>Flow</b>	(Hamra & Attallah, 2011)
Probe vehicles - RFID	<b>Speed</b>	(Wang et al., 2011)
Probe vehicles - RFID	<b>Density</b>	(Wang et al., 2011)
Probe vehicles - RFID	<b>Density</b>	(Ding et al., 2012)
Probe vehicles - RFID	<b>Time</b>	(Herrera et al., 2010)
Probe vehicles - RFID	<b>Vehicle Characteristics</b>	(Thajchayapong et al., 2013)
Probe vehicles - RFID	<b>Vehicle Characteristics</b> (ID)	(Herrera et al., 2010)
Probe vehicles - RFID	<b>Vehicle Characteristics</b> (type)	(Ding et al., 2012)

## Appendices

Probe vehicles- Mobile	<b>Position</b>	(Leduc, 2008)
Probe vehicles- Mobile	<b>Speed</b>	(Leduc, 2008)
Probe vehicles- Mobile	<b>Speed</b>	(Syed et al., 2014)
Probe vehicles- Mobile	<b>Speed</b>	(Herrera et al., 2010)
Probe vehicles- Mobile	<b>Speeds</b>	(Wismans et al., 2014)
Probe vehicles- Mobile	<b>Direction</b>	(Leduc, 2008)
Probe vehicles- Mobile	<b>Travel times</b>	(Lopes et al., 2010)
Probe vehicles- Mobile	<b>Travel time</b>	(Turner et al., 1998)
Probe vehicles- Mobile	<b>Travel times</b>	(Wismans et al., 2014)
Probe vehicles- Mobile	<b>OD Flows</b>	(Lopes et al., 2010)
Probe vehicles- Mobile	<b>OD pairs</b>	(Wismans et al., 2014)
Probe vehicles - Crowd	<b>Real time traffic incidents</b>	(Raphiphan et al., 2014).
Probe vehicles- Mobile	<b>Queue detection</b>	(Leduc, 2008)
Probe vehicles- Mobile	<b>Sub path flows</b>	(Lopes et al., 2010)
Probe vehicles- Mobile	<b>Traffic Flow</b>	(Wismans et al., 2014)

**APPENDIX 11. COST AND BANDWIDTH PERFORMANCE.**

Quantitative comparison of data collection techniques (Turner et al. 1998)

Technique	Initial or Capital Costs	Operating Costs (per unit of data collected)	Required Skill or Knowledge Level	Data Reduction and/or Processing	Route Flexibility	Accuracy and Representativeness <sup>a</sup>	Sampling Rate		
							Time	Space	Vehicles
<b>Test Vehicle</b>									
Manual	low	high	low	poor	excellent	fair	low	moderate	low
DMI	moderate	moderate	moderate	good	excellent	good	low	high	low
GPS	moderate	moderate	moderate	good	excellent	good	low	high	low
<b>License Plate Matching</b>									
Manual	low	high	low	poor	good	fair	low	low	moderate
Portable Computer	moderate	moderate	moderate	good	good	good	moderate	low	high
Video with Manual Transcription	low	moderate	moderate	fair	fair	excellent	high	low	high
Video with Character Recognition <sup>b</sup>	high	low	high	good	fair	excellent	high	low	high
<b>ITS Probe Vehicle<sup>c</sup></b>									
Signpost-Based	high	moderate	high	good	poor	good	moderate	low	low
AVI	high	low	high	good	poor	excellent	high	low	moderate
Ground-based Radio Navigation	high	low	high	fair	good	good	moderate	moderate	moderate
GPS	moderate	low	high	fair	good	good	moderate	high	moderate
Cellular Phone Tracking	high	low	high	fair	good	good	high	moderate	moderate

Cost of some detectors (Leduc, 2008)

Unit Cost Element	Lifetime (years)	Capital Cost (\$1000)	Cost Date	O&M Cost (\$1000)	Cost Date
Inductive Loop Surveillance on Corridor	5	3-8	2001	0.4-0.6	2005
Inductive Loop Surveillance at Intersection	5	8.6-15.3	2005	0.9-1.4	2005
Machine Vision Sensor on Corridor	10	21.7-29	2003	0.2-0.4	2003
Machine Vision Sensor at Intersection	10	16-25.5	2005	0.2-1	2005
Passive Acoustic Sensor on Corridor		3.7-8	2002	0.2-0.4	1998
Passive Acoustic Sensor at Intersection		5-15	2001	0.2-0.4	2002
Remote Traffic Microwave Sensor on Corridor	10	9-13	2005	0.1-0.58	2005
Remote Traffic Microwave Sensor at Intersection	10	18	2001	0.1	2001
Infrared Sensor Active		6-7.5	2000		
Infrared Sensor Passive		0.7-12	2002		
CCTV Video Camera	10	9-19	2005	1-2.3	2004
CCTV Video Camera Tower	20	4-12	2005		

## Appendices

### Traffic output data, communications bandwidth, and cost of commercially available sensors (Klein et al., 2006)

Sensor technology	Count	Presence	Speed	Output data	Classification	Multiple lane, multiple detection zone data	Communication bandwidth	Sensor purchase cost <sup>a</sup> (each in 1999 U.S. \$)
Inductive loop	✓	✓	✓ <sup>b</sup>	✓	✓ <sup>c</sup>		Low to moderate	Low <sup>w</sup> (\$500–\$800)
Magnetometer (two axis fluxgate)	✓	✓	✓ <sup>b</sup>	✓			Low	Moderate <sup>i</sup> (\$900–\$6,300)
Magnetic induction coil	✓	✓ <sup>d</sup>	✓ <sup>b</sup>	✓			Low	Low to moderate <sup>i</sup> (\$385–\$2,000)
Microwave radar	✓	✓ <sup>e</sup>	✓	✓ <sup>e</sup>	✓ <sup>e</sup>	✓ <sup>e</sup>	Moderate	Low to moderate (\$700–\$2,000)
Active infrared	✓	✓	✓ <sup>f</sup>	✓	✓	✓	Low to moderate	Moderate to high (\$6,500–\$3,300)
Passive infrared	✓	✓	✓ <sup>f</sup>	✓			Low to moderate	Low to moderate (\$700–\$1,200)
Ultrasonic	✓	✓		✓			Low	Low to moderate (Pulse model: \$600–\$1,900)
Acoustic array	✓	✓	✓	✓		✓ <sup>g</sup>	Low to moderate	Moderate (\$3,100–\$8,100)
Video image processor	✓	✓	✓	✓	✓	✓	Low to high <sup>h</sup>	Moderate to high (\$5,000–\$26,000)

<sup>a</sup> Installation, maintenance, and repair costs must also be included to arrive at the true cost of a sensor solution as discussed in the text.



**APPENDIX 12. AHP RESULTS ANALYSIS**

AHP priority vector matrix version 1.1

Normalization	Reduce negative impacts	Improve efficiency using ICT/ITS	Optimize infrastructure	Enhance Policy-Making	Congestion	Pollution	Safety	Noise Pollution	Air Pollution	Optimal Route	Logistics improv.	Roads	Intersections	Parking	Regulations	Stakeholders	criteria weight vector	alternatives scores	overall value of each option	alternatives 4th level
Reduce negative impacts	0,39	0,42	0,41	0,34													0,39			
Improve efficiency using ICT/ITS	0,17	0,18	0,18	0,21													0,18			
Optimize infrastructure	0,23	0,24	0,24	0,27													0,25			
Enhance Policy-Making	0,21	0,15	0,16	0,18													0,17			
Congestion					0,2	0,2	0,2											0,2	0,090	
Pollution					0,3	0,3	0,3											0,3	0,128	
Safety					0,4	0,4	0,4											0,4	0,174	
Noise Pollution								0,25	0,25									0,3		0,03
Air Pollution								0,75	0,75									0,7		0,10
Optimal Route										0,46	0,46							0,5	0,084	
Logistics improv.										0,54	0,54							0,5	0,100	
Roads												0,33	0,31	0,39				0,3	0,084	
Intersections												0,49	0,46	0,41				0,5	0,113	
Parking												0,17	0,22	0,20				0,2	0,049	
Regulations															0,53	0,53		0,5	0,094	
Stakeholders															0,47	0,47		0,5	0,082	

Appendices

AHP priority vector matrix version 2

Normalization	Reduce negative impacts	Improve efficiency using ICT/ITS	Optimize infrastructure	Enhance Policy-Making	Congestion	Pollution	Safety	Noise Pollution	Air Pollution	Optimal Route	Logistics improv.	Roads	Intersections	Parking	Regulations	Stakeholders	criteria weight vector	alternatives scores	
																		overall value of each option	alternatives 4th level
Reduce negative impacts	0,38	0,46	0,38	0,27													0,37		
Improve efficiency using ICT/ITS	0,15	0,18	0,20	0,28													0,21		
Optimize infrastructure	0,31	0,28	0,31	0,33													0,31		
Enhance Policy-Making	0,16	0,08	0,11	0,12													0,12		
Congestion					0,4	0,4	0,45											0,43	0,16
Pollution					0,2	0,2	0,22											0,23	0,08
Safety					0,3	0,3	0,34											0,34	0,13
Noise Pollution								0,3	0,3									0,29	
Air Pollution								0,7	0,7									0,71	0,02
Optimal Route										0,4	0,4							0,37	0,07
Logistics improv.										0,6	0,6							0,63	0,13
Roads												0,3	0,3	0,3				0,31	0,09
Intersections												0,4	0,4	0,3				0,39	0,11
Parking												0,3	0,3	0,3				0,30	0,09
Regulations															0,47	0,47		0,47	0,05
Stakeholders															0,53	0,53		0,53	0,062

**APPENDIX 13. DATA COLLECTION METHODS DEPLOYMENT SCENARIOS.**

The following scenarios are proposed utilizing the best ranked methods in the QFD results. The scenarios are created under the assumption that the deployment of the methods is restricted to only five points of importance in the city. Scenario 1 is for collecting freight traffic data of the entire city of Eindhoven. Scenario 2 is proposed as a case study that can test the obtained results of this thesis. Both scenarios recommend the partnership with a research institution as the Technology University of Eindhoven (TU/e) for the adoption of probe vehicles as data collection methods. The amount of the necessary vehicles is out of the scope of this research.

**Scenario 1.** The city traffic monitoring is recommended to be done together with a traffic monitoring program in the entire Netherlands. Creating a TCC that monitors in real-time the major highways of the country. The information obtained from the highway traffic status can assist the sensors to be deployed exclusively for Eindhoven. This scenario propose the combination of probe vehicles with manual processing video sensors managed by a national TCC. An alternative, in case the probe vehicles are not adopted, are video camera sensors with an automatic video image processing system (ITS) also managed by the TCC. Five locations for deploying the sensors are proposed in figure A-2. The locations take into account the traffic generated by A2, A50, A58, A67, and A270 highways, and the TU/e and High Tech campus collaboration and location

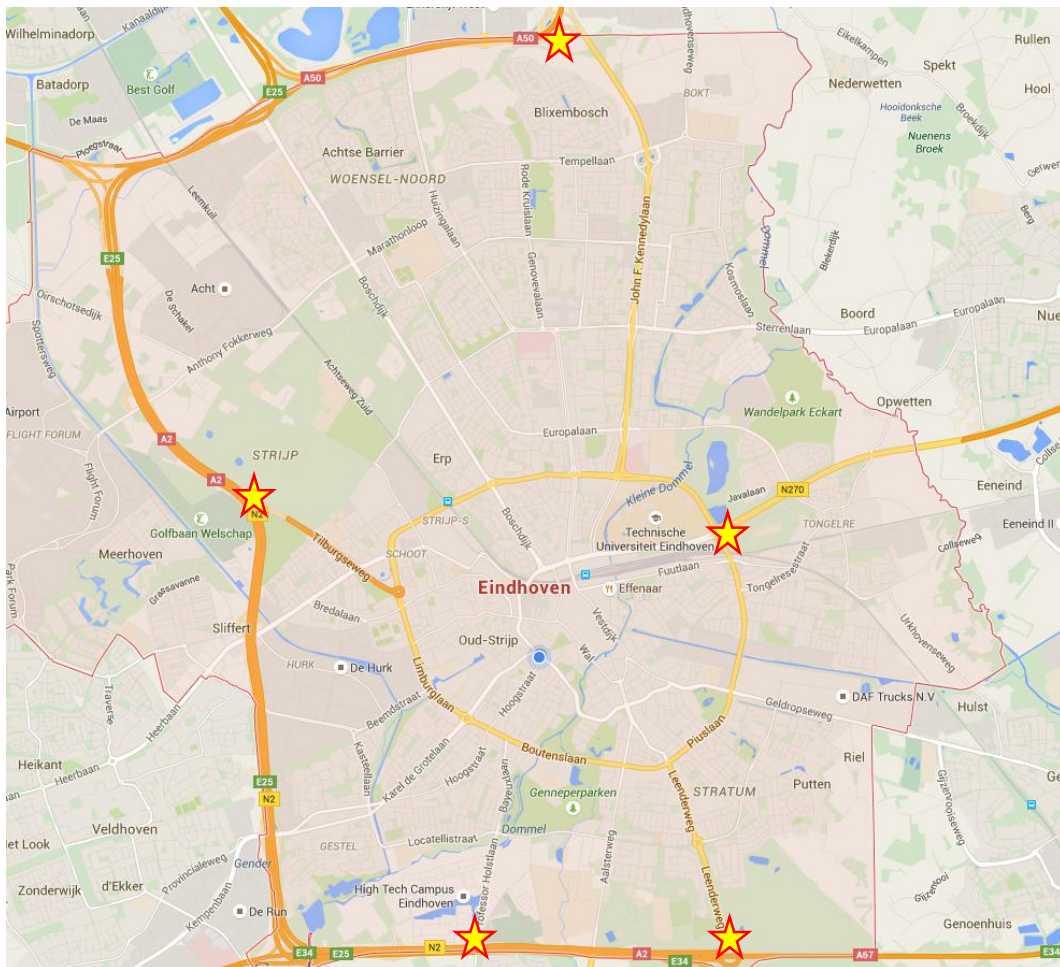

Figure A-2 Traffic collection methods deployment – City of Eindhoven

**Scenario 2.** Five locations and four methods deployment are proposed in figure A-3. This scenario propose a traffic data collection system based in probe vehicles. The methods in figure A-3 are complementary, this scenario aims only to evaluate their performance.

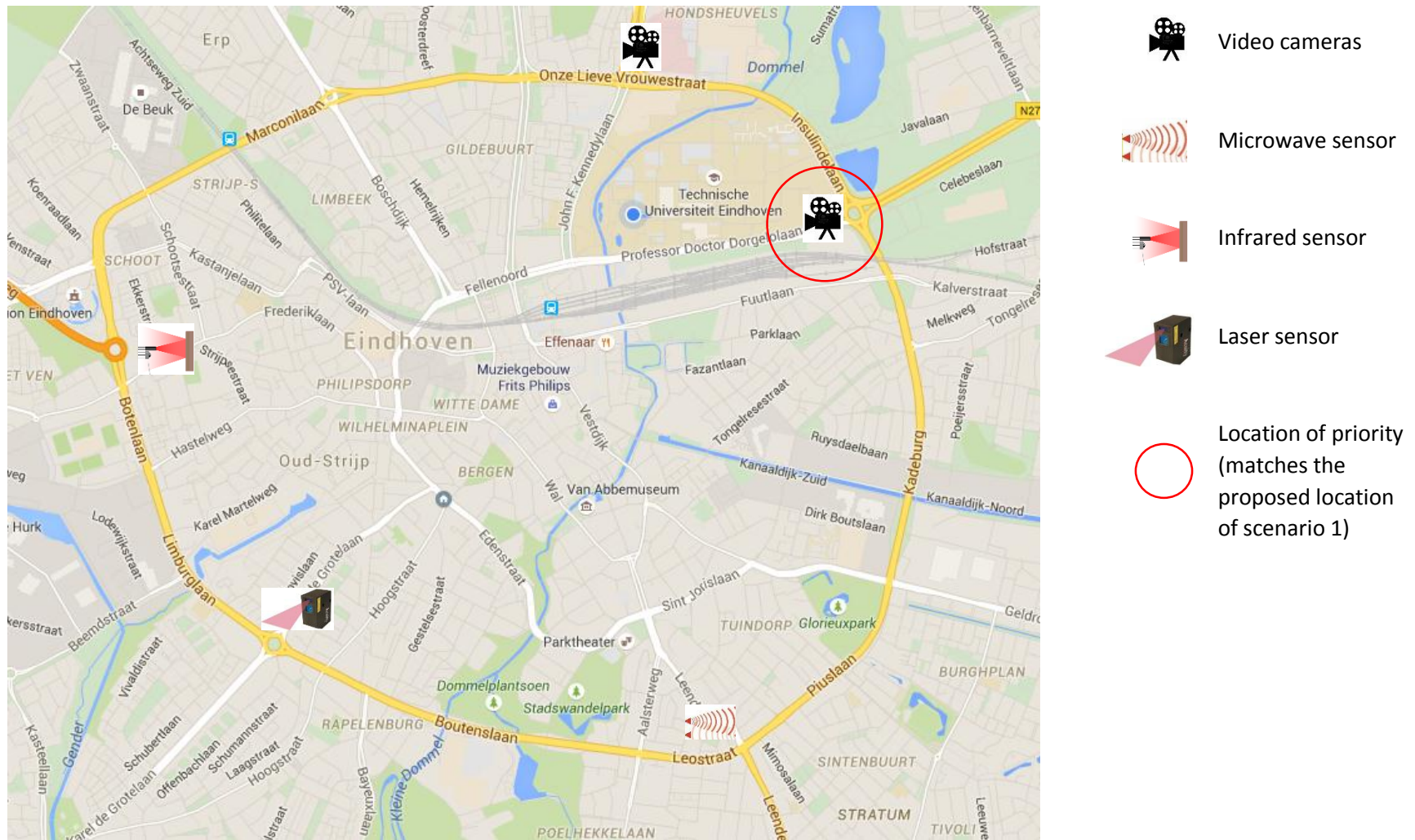

Figure A-3 Traffic collection methods deployment – Eindhoven Ring