

Single shot DoA estimation for large-array base station systems in multi-user environments

Bressner, T.A.H.; Johannsen, U.; Smolders, A.B.

Published in:

2017 Loughborough Antennas & Propagation Conference (LAPC)

DOI:

[10.1049/cp.2017.0288](https://doi.org/10.1049/cp.2017.0288)

Published: 13/11/2017

Document Version

Publisher's PDF, also known as Version of Record (includes final page, issue and volume numbers)

Please check the document version of this publication:

- A submitted manuscript is the author's version of the article upon submission and before peer-review. There can be important differences between the submitted version and the official published version of record. People interested in the research are advised to contact the author for the final version of the publication, or visit the DOI to the publisher's website.
- The final author version and the galley proof are versions of the publication after peer review.
- The final published version features the final layout of the paper including the volume, issue and page numbers.

[Link to publication](#)

Citation for published version (APA):

Bressner, T. A. H., Johannsen, U., & Smolders, A. B. (2017). Single shot DoA estimation for large-array base station systems in multi-user environments. In 2017 Loughborough Antennas & Propagation Conference (LAPC) [64] London: Institution of Engineering and Technology (IET). DOI: 10.1049/cp.2017.0288

General rights

Copyright and moral rights for the publications made accessible in the public portal are retained by the authors and/or other copyright owners and it is a condition of accessing publications that users recognise and abide by the legal requirements associated with these rights.

- Users may download and print one copy of any publication from the public portal for the purpose of private study or research.
- You may not further distribute the material or use it for any profit-making activity or commercial gain
- You may freely distribute the URL identifying the publication in the public portal ?

Take down policy

If you believe that this document breaches copyright please contact us providing details, and we will remove access to the work immediately and investigate your claim.

Single shot DoA estimation for large-array base station systems in multi-user environments

T.A.H. Bressner, U. Johannsen, A.B. Smolders*

*Eindhoven University of Technology, Fac. of Electrical Engineering, Den Dolech 2, 5600 MB Eindhoven, The Netherlands,
Email: T.A.H.Bressner@tue.nl

Keywords: base stations, direction of arrival estimation, beamforming, 5G mobile communication, millimeter wave communication.

Abstract

The next generation of wireless communications has to deal with the demand for higher data rates and the increase of subscribers. A feasible approach to cope with these challenges is to utilize millimeter waves (mmWaves). To provide at these high frequencies a sufficient high signal to noise ratio (SNR) narrow beam antenna systems can be used. These systems require knowledge about the direction of arrival (DoA) to steer their beams towards the optimal direction. The determination of the DoA can become time consuming for large areas where a single narrow beam can cover only a small spot. Dealing with this challenge, the single shot DoA enables to find the optimal direction within an instant of time for multiple users. This paper introduces the single shot DoA method and shows its functionality based on conducted simulations.

1 Introduction

A feasible approach to deal with challenges of the next mobile communications generation is to utilize mmWaves. This means that larger spectra become available and the use of massive MIMO systems becomes applicable. However, to reach far away users with a sufficiently high signal to noise ratio (SNR) gets more challenging and in addition the hardware complexity of a massive MIMO systems has to be handled.

To obtain a better SNR coverage narrow beam antenna systems can be used to increase the effective isotropic radiated power (EIRP) by increasing the antenna gain. This could be achieved by using large phased-arrays or reflector antennas with focal plane arrays presented in [1]. For instance, the European project SILIKA, [2], researches on potential use of reflectors for novel base station systems in 5G. The main advantage of focal plane arrays is that the feeding system shrinks since a large amount of EIRP is not provided by the active antenna elements. Instead the improvement is achieved due to its narrow beam that is mainly obtained by its reflector shield. Hence, also for sub-array structures the beam is highly focused. Nevertheless, narrow beam systems struggle to find the optimal direction of

arrival (DoA) since they are not able to cover the entire area of interest simultaneously. Approaching this by scanning the area of interest might be not feasible because of time urgency and changing environment. More desirable is an instant solution that provides instantly good estimates of optimal DoAs. Focusing on this, the single shot DoA makes use of large-arrays that have sub-array structures. Where each sub-array is then used to observe a certain area and to estimate the optimal direction. Besides this, the hardware complexity of large-arrays is getting lowered by using sub-arrays like it is stated in [3].

In this paper a single shot DoA solution is proposed that will help large-array base station systems, like in [2], to estimate instantly the optimal DoAs of multiple users. Section 2 describes the single shot DoA method. Section 3 presents the obtained simulation results to show the functionality of this method. In Section 4 a conclusion as well as an outlook are given.

2 Single shot direction of arrival method

Antenna systems with large-arrays have the possibility to divide their array into sub-arrays to lower the system complexity. For instance this is applied in the focal line/plane array (FLA/FPA) approach of SILIKA [2]. Besides lowering complexity the sub-array structure can be used to observe prior defined spots within a cell. As illustrated in Fig. 1 the large array base station consists of several sub-arrays where each uses only one analog to digital converter (ADC). When the single shot DoA is scheduled, all sub-arrays are steered so that they illuminate their prior defined spots, while user equipments (UEs) can be located anywhere within the cell. The spot size depends on the number of available sub-arrays and the entire cell size, so that the whole area of interest is monitored. After the optimal directions are identified, the sub-arrays can be electrical steered towards the optimal directions to transmit data.

2.1 Signal model

Each sub-array accumulates incoming signals arriving of their corresponding spot due to their narrow beam. These signals are individually distorted by a channel coefficient h and deferred due to multipath by a channel delay of τ . This is represented in Fig. 2 by the tapped delay line model. Based on this signal

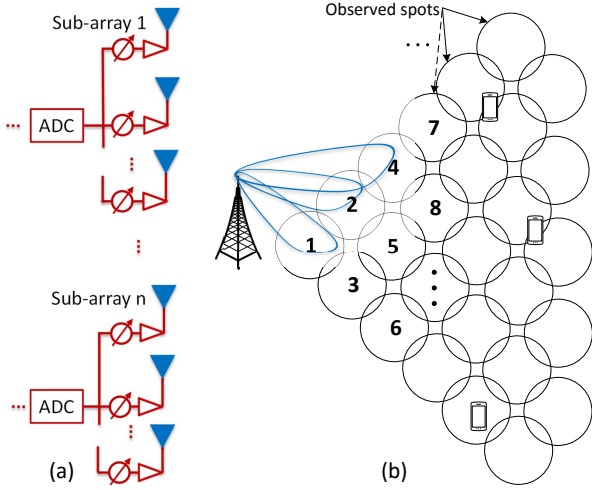

Fig. 1: Concept showing (a) sub-array structure (b) observation of prior defined spots. Each spot is observed by one sub-array.

model the received signal at the n -th sub-array is

$$y_n = \sum_{m=1}^T \sum_{d=1}^D x_m(\tau_d) \cdot h_{nm}(\tau_d) + N, \quad (1)$$

where T is the total number of UEs, D is the total number of delays, $x_m(\tau_d)$ is the transmitted pseudo-random pilot signal by UE m at a delay of τ_d , $h_{nm}(\tau_d)$ is the channel coefficient between UE m and sub-array n at a delay of τ_d , and N is additive white Gaussian noise.

2.2 Method description

Based on the described scenario and signal model the transmitted orthogonal pilot signals are received by sub-arrays. The accumulated received signal can then be cross-correlated with the reference signal of each pseudo-random pilot signal that is assigned to this cell by calculating

$$\rho_{y_n, x_m}[i] = \sum_{t=0}^S y_n[t] x_m^*[t - i], \quad (2)$$

where x_m is the reference signal of UE m , S is the maximum pilot length and $(\cdot)^*$ denotes the complex conjugate. Based on the cross-correlation, it can be identified if a signal of UE m is received by sub-array n and this can be linked to its corresponding spot. Furthermore, incoming signals that are not coming from this spot are highly suppressed by the narrow radiation pattern. Therefore, multiple users can be treated simultaneously and at the same frequency. To evaluate the cross-correlation output, the peak to average ratio (PAR) can be taken. This helps to classify the received pilot signal strength compared to noise and interference. The value is obtained by

$$R_{\text{PAR}, n, m} = \frac{\max(\rho(y_n, x_m))}{\text{mean}(\rho(y_n, x_m))}. \quad (3)$$

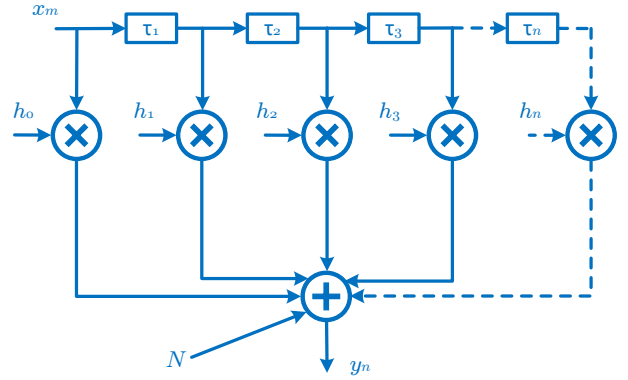

Fig. 2: Tapped delay line model applied to accumulate received signals.

Afterwards, the obtained PAR values can be compared to find the optimal DoA. Due to propagation phenomena like reflection and scattering it is likely that there are several directions from which a strong signal is received. Hence, it is likely of finding several directions for a single UE that can be utilized.

3 Simulation results

For a functionality test the 3D multi-cell channel model QuaDRiGa, [4], is used to simulate the scenario including sub-array radiation patterns and distributed UEs. The applied propagation model is based on the result of the European project mmMagic that is presented in [5]. The channel coefficients and delays, obtained in QuaDRiGa, are then used to compute the received signal based on Eq. (1). For testing purposes the scenario is based on parameters given in Table 1. The area of interest is divided into equally sized spots, where each spot is illuminated by one sub-array. This means, for nearby spots the beam size is broader compared to spots in far distance.

In Fig. 3 the case of having a single UE located near the base station is shown. Each coloured circle pinpoints the centre beam of a single sub-array where the size of these circles indicate the degree of correlation. A small circle means no correlation, while a large circle means high correlation. In this case a line-of-sight (LOS) environment is chosen, therefore a strong signal is detected from the spot of where the UE is located. In addition, two minor reflections are detected that provide a good link too. In Fig. 4 the environment is changed to non-line-of-sight (NLOS). Hence, only a weak signal is received directly from the position of where the UE is located. Instead several reflections are detected. In Fig. 5 this is repeated for a UE that is located further away. In this case a strong signal is received from one spot around coordinates (42,14) due to reflection.

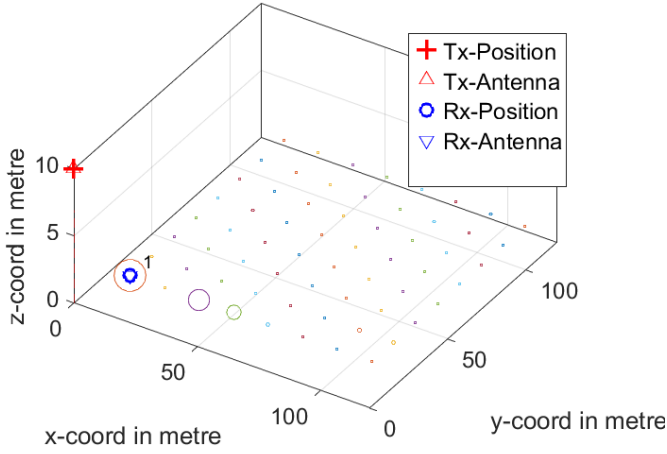

Fig. 3: Near located UE in a LOS environment.

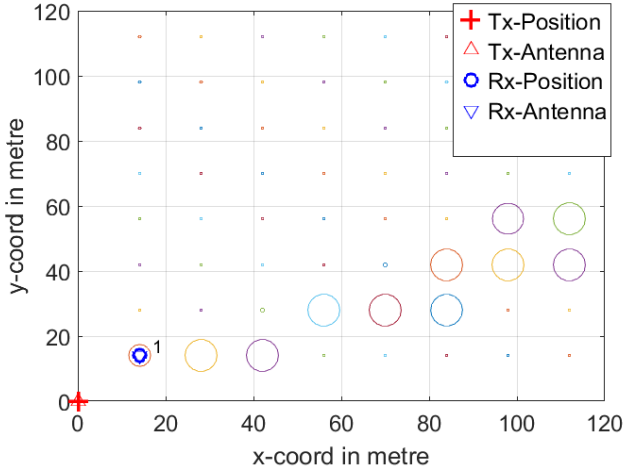

Fig. 4: Near located UE in a NLOS environment.

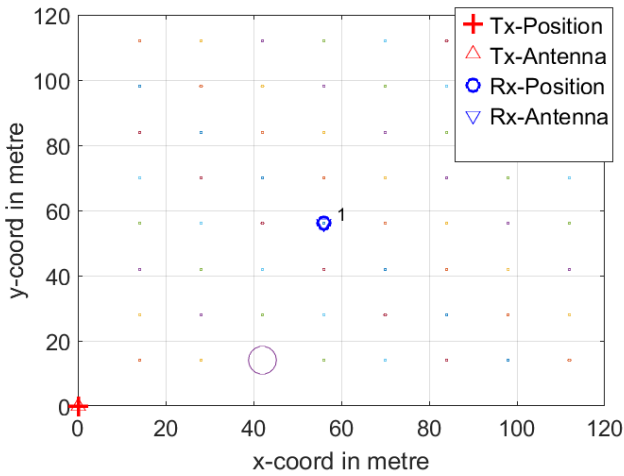

Fig. 5: Central located UE in a NLOS environment.

Parameter	Value
Frequency [GHz]	30
Channel bandwidth [MHz]	20
Area size [m ²]	150
Tx height [m]	10
Rx height [m]	1.5
Number of UEs	1
UE Tx power [dBm]	23
Propagation Model	LOS and NLOS [5]
Noise power [dBm]	-128

Table 1: Applied simulation parameters.

4 Conclusion

This paper proposed a single shot DoA method that can be applied on large-arrays. Based on the mathematical description it is implemented and simulated. The outcome shows that it is possible to obtain the DoA by letting sub-arrays observing the area while the pilot signals are transmitted. This direction can be towards the position of the UE, or towards the strongest reflection, depending in LOS or NLOS conditions. This gives the advantage that not the entire area has to be scanned and the DoA can be determined in an instant of time.

This paper has shown the functionality of single shot DoA in a scenario of a single UE. In the next step the functionality has to be shown if several UEs are dropped randomly that are transmitting their pilot signal simultaneously. Furthermore, advanced cases like moving UEs have to be investigated. In addition since the simulations have shown that it is likely to receive more than one feasible directions, a rule of thumb to decide which directions are considered and which are used.

Acknowledgements

This project has received funding from the European Union's Horizon 2020 research and innovation programme under the Marie Skłodowska-Curie grant agreement No 721732.

References

- [1] B. Rohrdantz, T. Jaschke, T. Reuschel, S. Radziejewski, A. Sieganschin, A. F. Jacob. "An Electronically Scannable Reflector Antenna Using a Planar Active Array Feed at Ka-Band," in IEEE Transactions on Microwave Theory and Techniques, vol. 65, no. 5, pp. 1650-1661, (2017).
- [2] SILIKA project, www.silika-project.eu, Accessed: 2017-05-01.
- [3] S. Han, C. I. I, Z. Xu, C. Rowell. "Large-scale antenna systems with hybrid analog and digital beamforming for millimeter wave 5G" in IEEE Communications Magazine, vol. 53, pp. 186-194, (2015).
- [4] S. Jaeckel, L. Raschkowski, K. Brner and L. Thiele, "QuaDRiGa: A 3-D Multi-Cell Channel Model With

Time Evolution for Enabling Virtual Field Trials,” in IEEE Transactions on Antennas and Propagation, vol. 62, no. 6, pp. 3242-3256, (2014).

- [5] mmMagic project, ”White paper W2.1: 6-100 GHz Channel Modelling for 5G: Measurement and Modelling Plans in mmMAGIC”, White Paper, Document Number:ICT-671650-mmMAGIC/W2.1. www.5g-mmmagic.eu, (2015).